

OVERVIEW

The EVAL-AD1852-EB evaluation board permits testing and demonstrating the high-performance AD1852 24-bit stereo DAC. An input signal is required in either optical or coaxial SPDIF format or, alternatively, directly via a 10-pin header in I²S, left justified, right justified, or DSP modes. A second 10-pin header and DB-9 connector allows control of the internal registers from an external SPI controller.

Power requirements are a clean 9 V to 12 V dc source for the digital section and a clean ± 12 V dc for the analog section. The positive supplies can be paralleled if desired. On-board regulators derive separate “clean” 5 V dc supplies for the digital and analog sections. Audio output is provided from two RCA phono jacks.

AD1852 OVERVIEW

The AD1852 is a complete 16-/20-/24-bit single-chip digital audio, stereo digital-to-analog converter (DAC). It is comprised of a multibit sigma-delta modulator with dither, continuous time analog filters, and differential analog outputs. Other features include an on-chip stereo attenuator, de-emphasis filter, selectable interpolator and mute control, programmed through

an SPI-compatible serial control port. The AD1852 is fully compatible with all known DVD formats including 96 kHz and 192 kHz sample rates and 24 bits. It also is backwards-compatible by supporting 50 μ s/15 μ s digital de-emphasis intended for “redbook” Compact Discs, as well as de-emphasis at 32 kHz and 48 kHz sample frequencies.

The AD1852 has a very simple, but very flexible, serial data input port that allows for a glueless interconnection to a variety of ADCs, DSP chips, digital interface receivers (DIR) and asynchronous sample rate converters (ASRC). The AD1852 can be configured in left-justified (LJ), I²S, right-justified (RJ), or DSP serial port compatible modes. It can support 16, 20, and 24 bits in all modes. The AD1852 accepts serial audio data in MSB first, two's complement format. A power-down mode is offered to minimize power consumption when the device is inactive. The AD1852 operates from a single 5 V power supply. It is fabricated on a single monolithic integrated circuit and housed in a 28-lead SSOP package. Normal operation over the temperature range 0°C to 70°C is guaranteed.

The AD1852 data sheet gives a more complete description of operation.

FUNCTIONAL BLOCK DIAGRAM

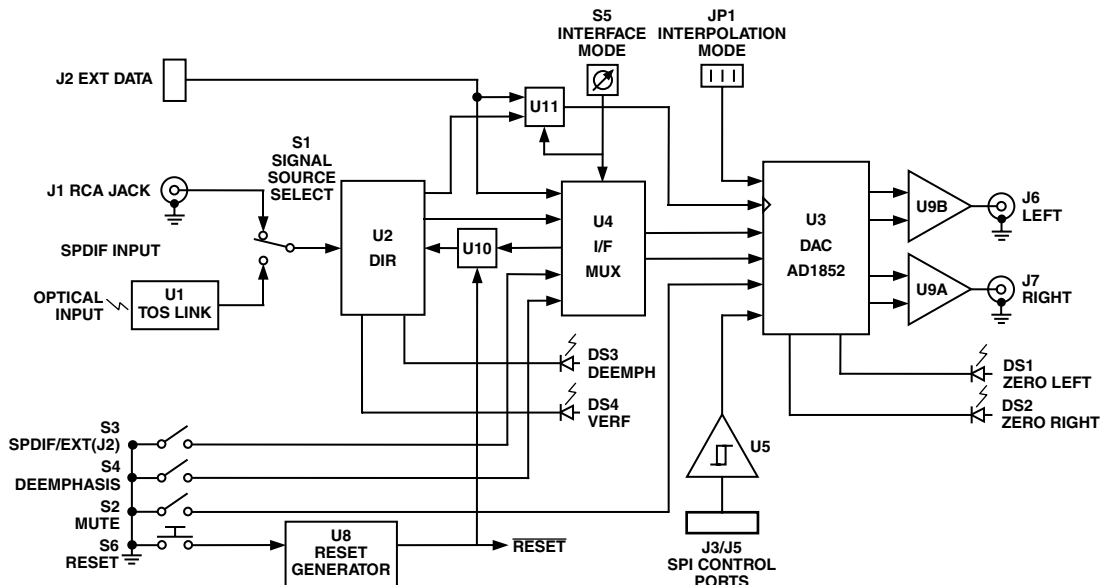

REV. 0

Information furnished by Analog Devices is believed to be accurate and reliable. However, no responsibility is assumed by Analog Devices for its use, nor for any infringements of patents or other rights of third parties which may result from its use. No license is granted by implication or

EVAL-AD1852EB

FUNCTIONAL DESCRIPTION

The AD1852 evaluation board presents a reference design that can be used as a suggested layout and circuit implementation, which will deliver optimal performance from the audio DAC. As far as is possible on an evaluation board, current assembly methods and components are used. Most components are surface mount devices and a four-layer printed circuit board is used with full internal power and ground planes for best noise performance. For guidance, a schematic, bill of materials, PLD source code, and PCB plots are included in this document.

POWER SUPPLIES

The PC board is divided into analog and digital sections, each with separate power supplies, to facilitate testing. The digital power supply input is via binding post terminals J8 and J9. The recommended digital supply is 12 V dc at 110 mA \pm 25 mA. An on-board voltage regulator (U6) provides 5 V dc, \pm 5% to the digital circuitry. The analog power supply inputs are binding posts, J10, J11, and J12. Recommended analog supply is 12 V dc at 50 mA \pm 10 mA and -12 V dc at -20 \pm 5 mA. An on-board, low noise voltage regulator, (U7) provides 5 V dc, \pm 5% to the analog power pins of the AD1852 DAC.

DIGITAL AUDIO SIGNAL INPUTS

RCA phone jack, (J1) and optical TOSLink input (U1) may be used for standard SPDIF or AES/EBU input signals. J1 is terminated with a 75 Ω resistor. Switch S1 selects between J1 and U1 inputs and feeds the selected signal to the digital interface receiver (U2). Switch SPDIF/EXT (S3) controls CPLD (U4) and U11, which is used to switch signals between the SPDIF input (J1) and the direct input, via the 10-pin header J2, EXT DATA INTERFACE.

The EXT DATA INTERFACE input permits buffered (U4, M4-64/32 and U11, HC00) access to the BCLK, L/RCLK, SDATA and MCLK inputs to the AD1852 DAC. This permits testing with left-justified, I²S or right-justified, serial input modes. Note that with right-justified input data, the AD1852 control register must be programmed for the correct number of data bits, i.e., 16, 20 or 24 bits. When using the direct input header, it is necessary to provide all four signals, MCLK, BCLK, L/RCLK and SDATA. A termination network (RC1), consisting of a series connected 100 Ω resistor and a 47 pF capacitor, is shunted across each signal line to reduce line reflections. A 10 k Ω pull-up network (RT1) ensures the inputs are not floating in the absence of an external data source.

EXTERNAL SPI CONTROL PORT

An external control port, SPI CONTROL PORT (J3), is provided, via a 10-pin header, so that the internal volume controls and control registers can be programmed from an external host or microcontroller. This port accepts serial data to independently set the left/right volume or the operating mode of the AD1852 by programming the contents of three internal 16-bit registers. When setting the volume, a 16-bit control word has 14 bits allocated to the left or right volume control, giving a total range of 84 dB. Details of the signal format and timing are discussed in the AD1852 data sheet.

An additional connector, PC PORT (J5), has been provided to permit connection to the parallel port of a computer. A termination network (RC2) consisting of a series-connected 100 Ω resistor and a 47 pF capacitor, is shunted across each signal line to reduce line reflections. Additionally, a Schmitt trigger (U5) reduces the effects of noise and line reflections. A 10 k Ω pull-up network (RT2) ensures the inputs are not floating in the absence of an external data source.

PC LabView software (LVAD1852EB.zip) can be downloaded from the Analog Devices, Inc., Digital Audio website, (http://www.analog.com/techsupt/eb/lin_eb/ad1852/ad1852.html) to program the internal control registers and set the left and right volume levels. An interface cable connects between the PC parallel printer port (LPTn) 25-pin Dsub connector and the 9-pin Dsub (J5) connector on the evaluation board. A suitable cable is Belkin Modem cable, part number 589604, F2L088-06

The pin-out for this cable is shown, in the table below, for users who wish to make their own cable.

Table I.

Function	PC (DB-25 Male)	EVAL Board (DB-9 Female)
Data 6	8	1
Data 1	3	2
Data 0	2	3
GND	20	4
Data 5	7	5
Data 4	6	6
Data 2	4	7
Data 3	5	8
GND	22	9
Chassis Shield GND	Case	Case

NOTE: When setting the internal control registers via the SPI port, it is essential to pull the corresponding external pins low as they are wire-OR'd with the SPI control registers. This applies to the interpolation mode pins, via JP1 (192/48 P7, 96/48 P10), the power down/reset pin, (RESET), the mute pin, (MUTE), the interface mode pins (IDPM1, IDPM0) and the de-emphasis control pin, (DEEMPH). Also note that when the right-justified interface mode is selected, either via the external pins or via the SPI port, the default data word width is 24 bits. It is necessary to select 16 or 20 bits via the SPI control register if these word lengths are required.

AUDIO SIGNAL OUTPUTS

RCA jacks J6 and J7 provide LEFT and RIGHT audio output signals. The output is filtered with a low-pass anti-image filter using an OP275 audio op amp (U9) which also converts the differential outputs of the AD1852 to single ended signals. The filter -3 dB cut-off frequency is 100 kHz and has an approximate Third Order Bessel (linear phase) response. The output source impedance is approximately 600 Ω . The full-scale output signal is 2 V rms (5.6 V p-p).

SWITCH AND JUMPER FUNCTIONS

- S1 is used to select between the RCA SPDIF INPUT (J1) and the TOSLINK optical input, (U1). The SPDIF signal is a self-clocking, Manchester-encoded signal that is decoded by the digital interface receiver (DIR, U2) to extract the left and right digital audio data and associated status signals.
- S2 is used to activate the AD1852 MUTE hardware function.
- S3 switches the CPLD (U4) digital input signals between the digital interface receiver (DIR, U2) and the EXT DATA INTERFACE (J2). The CPLD (U4) digital outputs go directly to the AD1852 DAC. In addition to the digital audio data signals, S3 also switches the master clock between the DIR (U2) and the Ext Data I/F input (J2) via the NAND gate (U11).
- S4 is used to enable the internal AD1852 DEEMPHASIS digital filter. This is confirmed by lighting the DEEMPH LED, (DS3).
- S5 selects the serial interface modes for the SPDIF receiver (U2) and the AD1852 DAC (U3):

Table II. Serial Interface Mode Selection

S5 Position	AD1852 Serial Interface Mode	IDPM1	IDPM0
0	Left Justified, 16 to 24 Bits	1	0
1	I ² S, 16 to 24 Bits	0	1
2	Right Justified, (U2 (DIR) is set for 24 Bits. Program the AD1852 via the SPI port for 24 Bits if using U2).	0	0
3	DSP Word Sync, 16- to 24-Bits	1	1
4	Serial Mode is set through SPI Port using LabView Software.	0	0
5	Spare – Not Used		
6	Spare – Not Used		
7	Spare – Not Used		

- S6 provides a RESET function via reset generator U8 (ADM811TART) and a “clean” 200 ms delay after release. U8 also provides a 200 ms delayed reset release at power-up. This ensures that the digital interface receiver (DIR, U2) and the AD1852 are correctly initialized after power-up and their internal registers are set to the correct default values.
- JP1 Header is used to select the internal interpolation ratio for the AD1852. Jumpers are selected according to the following table. The default is 8× interpolation, i.e., both jumpers are installed. NOTE: When the internal registers are used, the effective logic state is the logical OR of the external pin and the program register, hence both jumpers should be in place so that the programmable registers can correctly set the state of the control bits.

Table III.

Interpolation Ratio (SR)	96/48 (JP1-1)	192/48 (JP1-2)
8× (32 kHz to 50 kHz)	0	0
4× (64 kHz to 100 kHz)	0	1
2× (128 kHz to 200 kHz)	1	0
Not Allowed	1	1

Note: 0 = Closed.

Indicator Display LEDs

Five red LED indicators are provided for status indication.

- Display LEDs DS1, ZL and DS2, ZR show that the AD1852 is detecting a zero signal in either the left or right channel respectively.
- Display LED DS3, DEEMPH, indicates that either switch S4 has selected de-emphasis or that the incoming SPDIF signal has the EMPHASIS status bit set. In either case, illumination of DS3 indicates that the DEEMPHASIS filter function of the AD1852 is active.
- Display LED DS4, VERR, indicates that the digital interface receiver has detected an error condition in the received SPDIF signal or the SPDIF Invalid status bit has been set.
- Display LED DS5, POWER, shows the presence of 5 V dc on the analog 5 V power supply.

INTEGRATED CIRCUIT FUNCTIONS

There are 11 active devices on the AD1852 evaluation board. Following is a brief description of the function of each part.

- U1 (TORX173) is the Toshiba Digital Audio Optical (TOSLink) Receiver. This part accepts a visible red SPDIF-modulated signal and converts it to a standard TTL digital signal suitable for input to the digital audio receiver (U2).
- U2 (CS8414-CS) digital audio interface receiver, (DIR) receives and decodes the serial SPDIF, digital audio encoded signal. This signal is Manchester modulated and is self-clocked at a multiple of the encoded SPDIF sample rate. Four digital audio signals are decoded by the CS8414. The serial data SDATA, the master clock at 256 F_S, MCLK, the left/right frame clock L/RCLK and the serial bit clock at 64 F_S, BCLK.
- U3 (AD1852JRS) is the high performance stereo DAC. Depending upon selected modes of operation, (JP1) sample rates up to 192 kHz and 24 bits may be tested by changing the internal interpolation ratio. The interface mode can be selected for Left Justified (LJ), I²S or Right Justified (RJ) by means of the Interface Mode switch (S5). Internal registers of the AD1852 can be programmed via the PC Port (J5) or via the SPI Control Port, header (J3). Mute is controlled directly by the control switch S2. The De-emphasis filter can be turned on with the switch DEEMPH (S4) or pre-emphasis may be detected and enabled by the SPDIF receiver.
- U4 (M4-64/32) is a Vantis CPLD and has been programmed to provides input signal MUX selection, LED buffering and switch decoding for the different interface modes. The output interface mode of the DIR (U2) must be compatible with the input to the AD1852 (U3) and this is selected at the same time as the mode for the AD1852 is selected, with switch Interface Mode (S5). S5 is decoded to drive the DIR mode pins (M0-3) and AD1852 mode pins (IDPM0) and (IDMP1). The source code is included in Appendix A. Note: Because of excessive jitter degradation in CPLDs, a separate IC (U11) is used to select the MCLK input to the AD1852.
- U5 (74HC14) provides Schmitt trigger buffering for the SPI Control Port (J3) and PC Port (J5) signals. This helps to reduce problems due to noise and ringing on the signal lines.
- U6 (LM317) provides 5 V dc low voltage regulation for the digital section of the evaluation board.

EVAL-AD1852EB

- U8 (ADM811TART) is a RESET generator that provides a debounced 200 ms reset signal from the push button (S3) or on power up. The reset is active if the 5 V supply drops below 3 V.
- U7 (AD3303-5.0) is a low noise 5 V dc regulator for the analog section of the AD1852.
- U9 (OP275) is a low noise and distortion, audio op amp. U9 provides differential-to-single-ended conversion and a low-pass anti-image filter. A third order low-pass Bessel filter response is implemented with a -3 dB corner frequency of 100 kHz and a 60 dB/decade roll-off. This type of filter is characterized by a linear phase response and fast transient response without overshoot.
- U10 (74HC00) is used to provide a reset code to the digital interface receiver (U2), pins M0–3, at power up and also sends the correct interface code to ensure the digital output format matches the input of the DAC.
- U11 (74HC00) is used to select the correct master clock source for the DAC when it is switched between the SPDIF receiver (U2) and the Ext Data Interface (J2). A discrete logic gate is used for this function, because of the excessive jitter that modulates high-frequency clock signals when they are handled by PLDs.

PERFORMANCE SPECIFICATIONS

Typical performance, for a sample rate of 48 kHz, is tabulated below.

1. SNR, A-Weighted	-114 dBFS ± 1 dB
2. DNR, A-Weighted	-114 dBFS ± 1 dB
3. THD+N	-102 dBFS ± 2 dB
4. Frequency Response	± 0.2 dB, 10 Hz to 20 kHz
5. Noise Floor	-145 dBFS
6. Full-Scale Audio Output	2 V rms

ATTACHMENTS

The following is included for your convenience.

- Appendix A: ABEL Source Code for Vantis MACH4-64/32 CPLD.
- Appendix B: Set of Schematics, Figures 1 and 2.
- Appendix C: PCB plots showing the silkscreen layer, top signal layer, ground planes, power planes, and the bottom signal layer, Figures 3–7.

FURTHER INFORMATION

Ordering information: order number is EVAL-AD1852EB.

For application questions, please contact our Central Applications Department at 1-781-937-1428 for assistance.

APPENDIX A

```

MODULE                IF_Logic
TITLE                 'AD1852 EVB Logic'
//=====
// FILE:              1852ext.abl
// REVISION DATE:     11-01-99 (comment revisions on 2-9-00)
// REVISION BY:       Brian Wachob
// REVISION:          3.0 (plus comments)
//
//
// PREVIOUS FILE:     1852r9.abl, AD1852v8.abl
// PREVIOUS DATE:     10-01-99
// PREVIOUS REVISION: 2.0
//
// ORIGINAL AUTHOR:   Larry Hurst
//
// BOARD REV.:        This code is written for the "AD185_REV 1" eval. boards
//                    (with, of course, an AD1852 DAC installed on the eval. board)
//
// DESCRIPTION:
//
// This chip selects between the External Data Interface header (J2) and the
// onboard CS8414 DIR (U2) for the AD1852 DAC input signals, depending upon
// the SPDIF/EXT switch position (S3). When the DIR is the selected signal
// source the digital audio signals, SDATA, BCLK and LRCLK also appear at the
// external Data Interface header (J2) as outputs.
//
// It also decodes the Interface Mode Switch(S5) and sets the interface mode
// pins for both the CS8414 DIR and the AD1852 DAC and corrects the CS8414
// output signals for LJ, RJ, and DSP modes, to match the signal requirements
// for the AD1852.
//
// It also decodes signals from LabView SPI port control software so that it
// can correctly set the interface mode pins for the CS8414 and correctly
// format the CS8414 output signal for LJ, RJ, and DSP modes. (This
// functionality is required when the SPI port is used to set the data format
// used by the DAC instead of setting it directly via the IDPM pins with the
// Interface Mode Switch, S5.)
//
// It also decodes the Deemphasis control signal from the CS8414 (U2) and
// DEEMPH switch(S4), enables and buffers the output master clock and the
// VERF signal from the CS8414.
//
// Finally, the CPLD buffers and drives the status LEDs.
//
//=====
LIBRARY 'MACH';
MACH_SLEW(FAST,2,MCLK:MCLKO);

DECLARATIONS
// IF_Logic DEVICE 'M4-64/32-15VC';

`INPUTS _____
// TDI, TCK, TMS                pin 4, 7, 26;      //JTAG I/P's
// SLCT_C, SLCT_B, SLCT_A        pin 15, 19, 14;   //Interface Mode Select
// ISDATA, IMCLK, ILRCLK, IBCLK  pin 1, 5, 9, 10;  //DIR I/P's
// VERF, NPREEMPH, NDEEMPH       pin 44, 8, 13;    //DAC Control
// SPDIF_EXT                     pin 12;           //DAC Signal Source Select
// ZR, ZL                        pin 24, 34;         //DAC ZERO Signals
// EMCLK                         pin 27;           //External MCLK Input

```

EVAL-AD1852EB

```
MODCLK pin 40; /
/Clocks in serial mode codes
MODSTM pin 37; /
/Serial mode code stream from CPU

"OUTPUTS
// TDO pin 29; //JTAG O/P
M0, M1, M2 pin 3, 2, 18 istype 'com'; //DIR Mode Select
IDPM0, IDPM1 pin 35, 36 istype 'com'; //DAC Mode Select
MCLK, BCLK, LRCLK pin 30, 32, 33 istype 'com'; //DAC Digital Data
SDATA pin 31 istype 'com';
MCLKO pin 23 istype 'com'; //Ext MCLK Drive
DEEMPH pin 25 istype 'com'; //DAC Deemphasis Control
NLVERF, NLZL, NLZR, NLDEEMPH pin 11, 21, 22, 20 istype 'com'; //LED Status Drive
ESDATA, ELRCLK, EBCLK pin 43, 42, 41 istype 'com'; //External Data I/Os

// Registers for delaying the data in RJ and DSP modes
// such that it is output in the correct format
// to match the signal requirements for the AD1852.
"NODES
QA, QB, QC, QD, QE, QF node istype 'reg, buffer';
QG, QH, QI, QJ, QK, QL node istype 'reg, buffer';
Q20, Q24 node istype 'reg, buffer';
QDSP node istype 'reg, buffer';

// Shift register for reading/holding mode codes
// streaming in from CPU's LabView control program.
QM0, QM1, QM2, QM3 node istype 'reg, buffer';
"MACROS // S5 position 4, External Mode Control
XMODC = (!SLCT_C & SLCT_B & SLCT_A);
//EQUATIONS

// S5 position 0, LabView selection 1, LJ, Invert DIR BCLK
LJ = ( SLCT_C & SLCT_B & SLCT_A)
# ( XMODC & ( (!QM3 & QM2 & !QM1 & QM0)
# ( QM3 & !QM2 & QM1 & !QM0) ) );

// S5 position 1, LabView selection 2, I2S
I2S = ( SLCT_C & SLCT_B & !SLCT_A)
# ( XMODC & ( (!QM3 & QM2 & QM1 & QM0)
# ( QM3 & QM2 & QM1 & !QM0)
# ( QM3 & QM2 & !QM1 & QM0)
# ( QM3 & !QM2 & QM1 & QM0) ) );

// S5 position 2, LabView selection 4, RJ_24, 24-Bit
RJ_24 = ( SLCT_C & !SLCT_B & SLCT_A)
# ( XMODC & ( (!QM3 & !QM2 & !QM1 & QM0)
# (!QM3 & !QM2 & QM1 & !QM0)
# (!QM3 & QM2 & !QM1 & !QM0)
# ( QM3 & !QM2 & !QM1 & !QM0) ) );

// S5 position 3, LabView selection 3, DSP WSync, Delay SDATA
DSP = ( SLCT_C & !SLCT_B & !SLCT_A)
# ( XMODC & (!QM3 & !QM2 & !QM1 & !QM0) );

// LabView selection 5, RJ_20, 20-Bit
RJ_20 = ( XMODC & ( (!QM3 & !QM2 & QM1 & QM0)
# (!QM3 & QM2 & QM1 & !QM0)
# ( QM3 & QM2 & !QM1 & !QM0)
# ( QM3 & !QM2 & !QM1 & QM0) ) );
```

```

// LabView selection 6, RJ_16, 16-Bit
RJ_16 = ( XMODC & ( QM3 & QM2 & QM1 & QM0 ) );

"=====
EQUATIONS

// Registers holding streaming mode codes from CPU's LabView control program.
[QM3, QM2, QM1, QM0] := [QM2, QM1, QM0, MODSTM];
[QM3, QM2, QM1, QM0].clk = MODCLK;

// AD1852 DAC Interface Mode Select
IDPM0 = !XMODC & (I2S # DSP);
IDPM1 = !XMODC & (LJ # DSP);

// CS8414 DIR Interface Mode Select
M0 = !RJ_16;
M1 = !I2S;
M2 = !(DSP # RJ_16);

// External I/O Data Port Output Enabled by SPDIF_EXT
ESDATA.oe = SPDIF_EXT;
ELRCLK.oe = SPDIF_EXT;
EBCLK.oe = SPDIF_EXT;

ESDATA = SPDIF_EXT & SDATA;
ELRCLK = SPDIF_EXT & LRCLK;
EBCLK = SPDIF_EXT & BCLK;

// Shift register for DSP, RJ_20, and RJ_24 modes
[QL, QK, QJ, QI, QH, QG, QF, QE, QD, QC, QB, QA] := [QK, QJ, QI,
QH, QG, QF, QE, QD, QC, QB, QA, ISDATA];
[Q24, Q20] := [QH, QL];
QDSP := QA;

[QL, QK, QJ, QI, QH, QG, QF, QE, QD, QC, QB, QA].clk = !IBCLK;
[Q24, Q20].clk = IBCLK;
QDSP.clk = IBCLK;

// AD1852 DAC DAU Signals
SDATA = SPDIF_EXT & (ISDATA & (LJ # I2S # RJ_16)
# DSP & QDSP # RJ_20 & Q20 # RJ_24 & Q24) # !SPDIF_EXT & ESDATA;
LRCLK = SPDIF_EXT & ILRCLK # !SPDIF_EXT & ELRCLK;
BCLK = SPDIF_EXT & ((LJ # RJ_20 # RJ_24) & !IBCLK
# (I2S # DSP # RJ_16) & IBCLK) # !SPDIF_EXT & EBCLK;
MCLK = SPDIF_EXT & IMCLK
# !SPDIF_EXT & EMCLK;

// DAC Deemphasis Control Signal
DEEMPH = !NPREEMPH # !NDEEMPH;

// Slave MCLK for SPI output port
MCLKO = !MCLK;

// LED Status Driver Outputs - LED lights when output low
NLVERF = !VERF;
NLZL = !ZL;
NLZR = !ZR;
NLDEEMPH = !DEEMPH;

"=====
END IF_Logic

```

APPENDIX B - Schematics

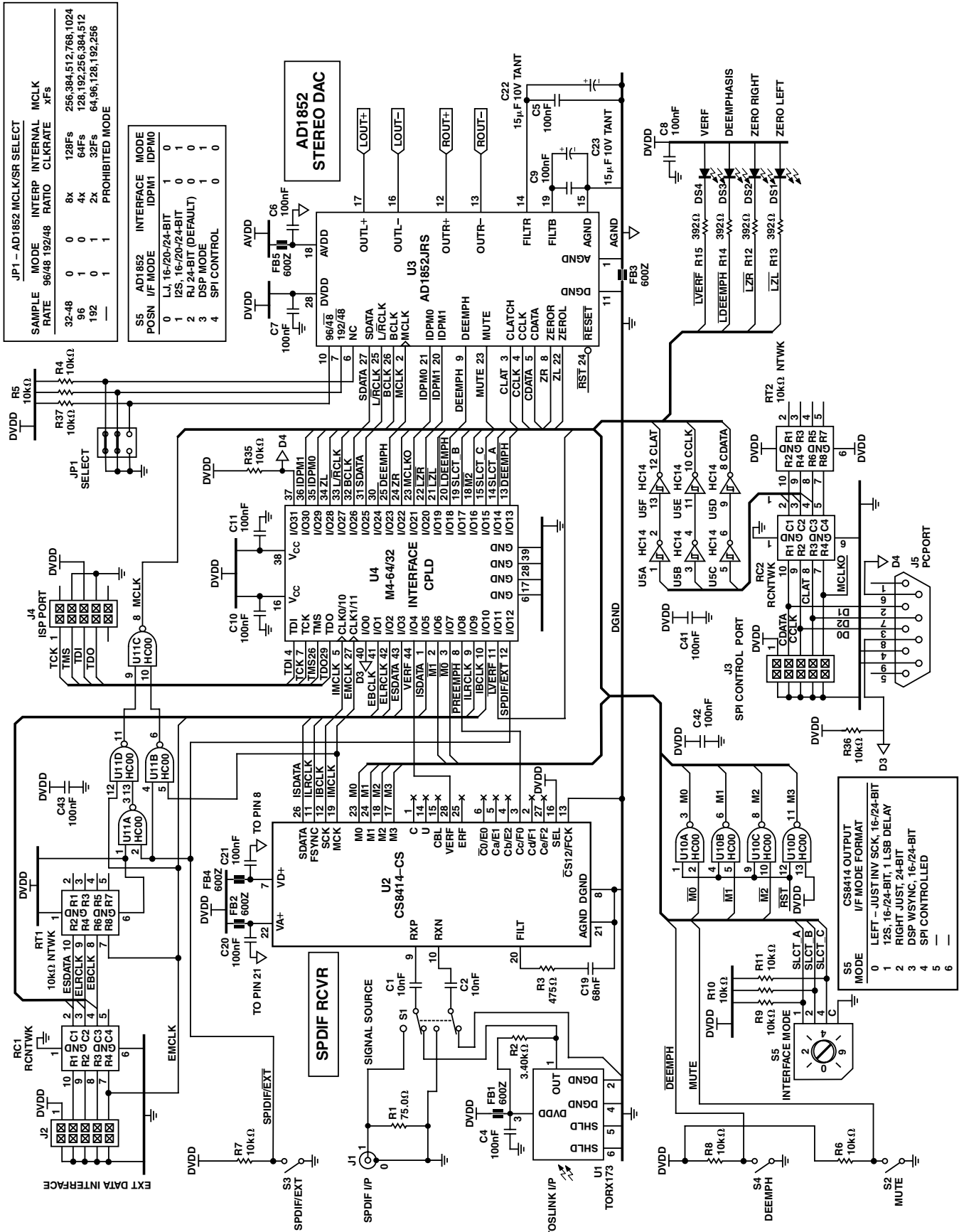

Figure 1. SPDIF Receiver, Interface CPLD and AD1852 DAC Circuits

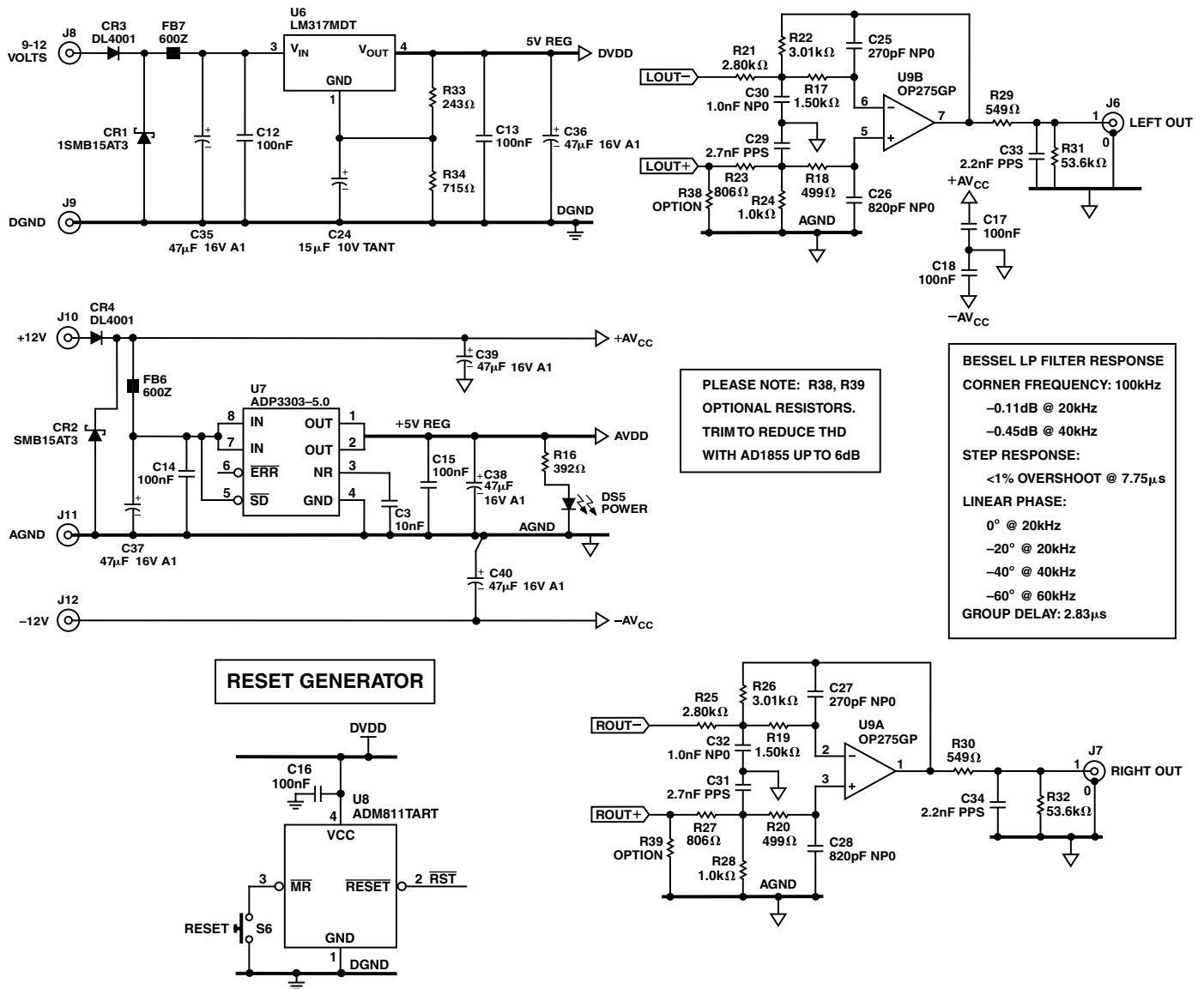

Figure 2. Anti-Image Filters, Power Supply Regulation, Reset Generator

APPENDIX C – Printed Circuit Board

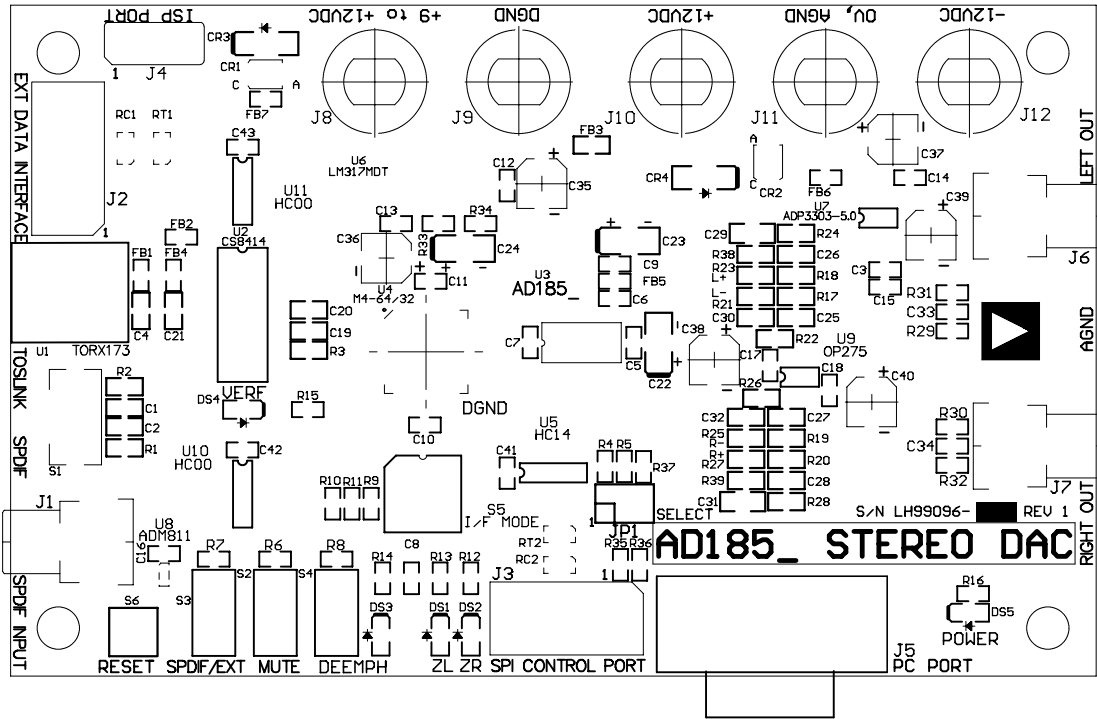

Figure 3. Silk Screen

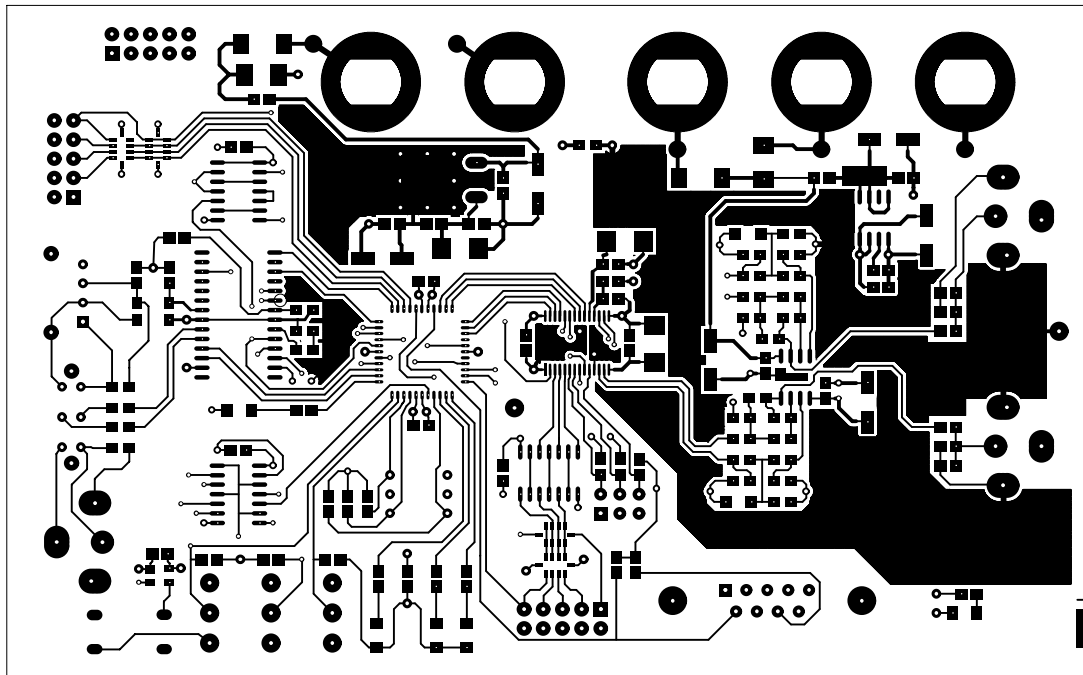

Figure 4. Top Layer (Component Side)

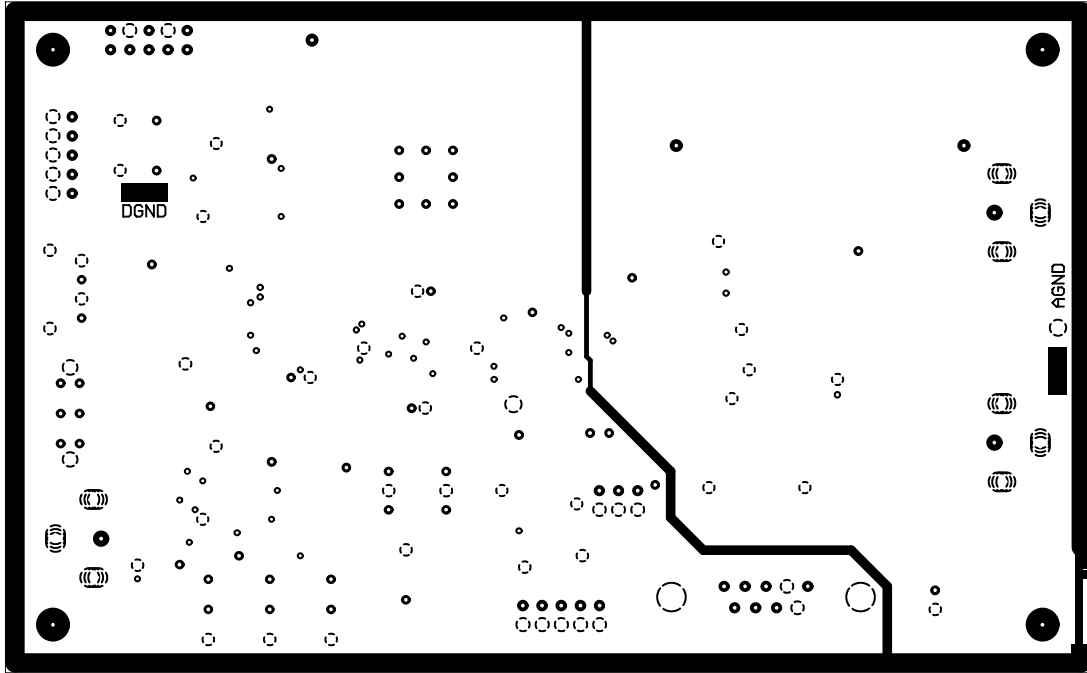

Figure 5. Ground Planes

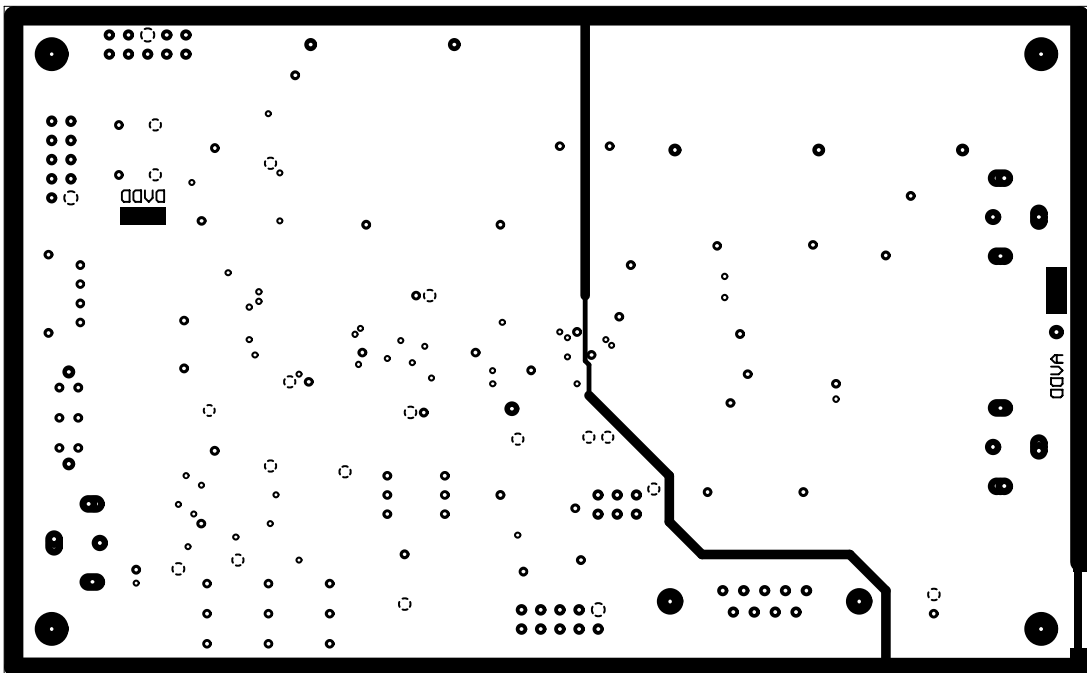

Figure 6. Power Planes

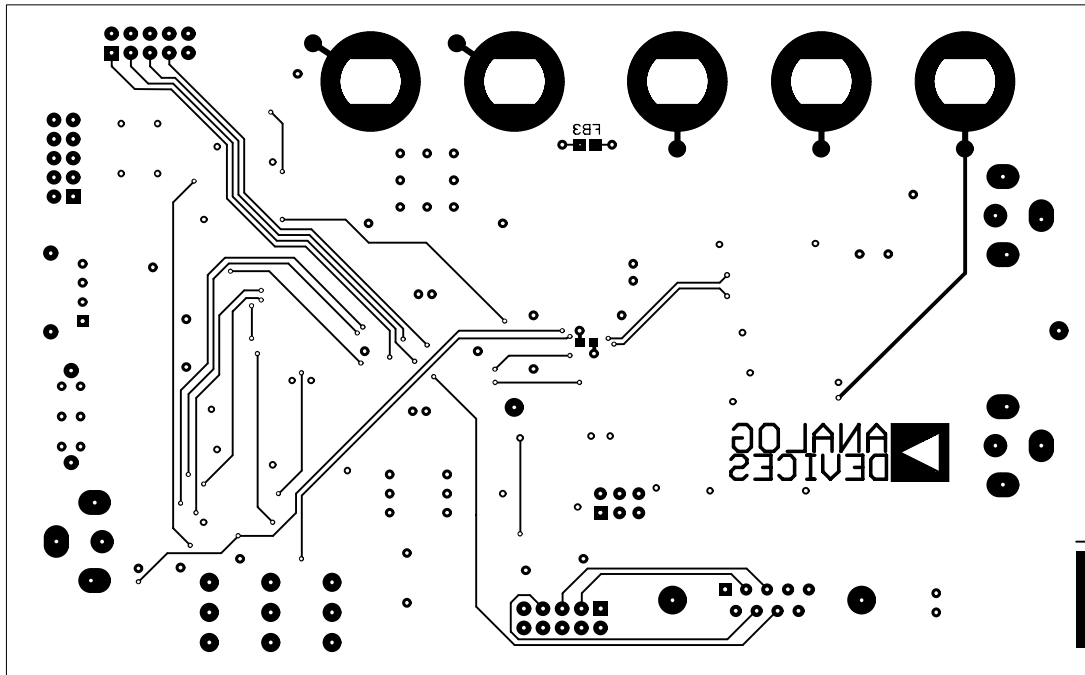

Figure 7. Bottom Layer (Solder Side)

APPENDIX D – Parts List
Bill of Materials for AD1852EB

Qty. Used	Part Type	Designator	Footprint	Description
3	10nF	C1, C2, C3	SMD 0805	10%, 50 V, X7R Multilayer Ceramic Capacitor
20	100nF	C4, C5, C6, C7, C8, C9, C10, C11, C12, C13, C14, C15, C16, C17, C18, C20, C21, C41, C42, C43	SMD 0805	10%, 50 V, X7R Multilayer Ceramic Capacitor
1	68nF	C19	SMD 0805	10%, 50 V, X7R Multilayer Ceramic Capacitor
3	15uF 10V Tant	C22, C23, C24	EIA Size B	20%, 10 VW, Tantalum Electrolytic Capacitor
2	270pF NP0	C25, C27	SMD 0805	5%, 50 V, NP0 Multilayer Ceramic Chip Capacitor
2	820pF NP0	C26, C28	SMD 0805	5%, 50 V, NP0 Multilayer Ceramic Chip Capacitor
2	2.7nF PPS	C29, C31	SMD 1206	5%, 50 V, PPS Plastic Film Chip Capacitor
2	1.0nF NP0	C30, C32	SMD 0805	5%, 50 V, NP0 Multilayer Ceramic Chip Capacitor
2	2.2nF PPS	C33, C34	SMD 0805	5%, 50 V, PPS Plastic Film Chip Capacitor
6	47µF 16V Al	C35, C36, C37, C38, C39, C40	Size Code D	20%, 16 VW, Low Impedance Aluminum Electrolytic
2	1SMB15AT3	CR1, CR2	SMD 403A	600 W, Transient Voltage Suppressor Zener Diode
2	DL4001	CR3, CR4	SOD80	50 V, 1A Diode/Rectifier
1	ZERO LEFT	DS1	SMD 1206	Red, Light Emitting Diode
1	ZERO RIGHT	DS2	SMD 1206	Red, Light Emitting Diode
1	DEEMPHASIS	DS3	SMD 1206	Red, Light Emitting Diode
1	VERF	DS4	SMD 1206	Red, Light Emitting Diode
1	POWER	DS5	SMD 1206	Red, Light Emitting Diode
7	600Z	FB1, FB2, FB3, FB4, FB5, FB6, FB7	SMD 0805	600 Ω @ 100 MHz, <1.0Ω DC, 200 mA Ferrite Bead
1	75.0Ω	R1	SMD 0805	1%, 100 mW, Thick Film SMD Resistor
1	3.40kΩ	R2	SMD 0805	1%, 100 mW, Thick Film SMD Resistor
1	475Ω	R3	SMD 0805	1%, 100 mW, Thick Film SMD Resistor
11	10kΩ	R4, R5, R6, R7, R8, R9, R10, R11, R35, R36, R37	SMD 0805	1%, 100 mW, Thick Film SMD Resistor
5	392Ω	R12, R13, R14, R15, R16	SMD 0805	1%, 100 mW, Thick Film SMD Resistor
2	1.50kΩ	R17, R19	SMD 0805	1%, 100 mW, Thick Film SMD Resistor
2	499Ω	R18, R20	SMD 0805	1%, 100 mW, Thick Film SMD Resistor
2	2.80kΩ	R21, R25	SMD 0805	1%, 100 mW, Thick Film SMD Resistor
2	3.01kΩ	R22, R26	SMD 0805	1%, 100 mW, Thick Film SMD Resistor
2	806Ω	R23, R27	SMD 0805	1%, 100 mW, Thick Film SMD Resistor
2	1.0kΩ	R24, R28	SMD 0805	1%, 100 mW, Thick Film SMD Resistor
2	549Ω	R29, R30	SMD 0805	1%, 100 mW, Thick Film SMD Resistor
2	53.6Ω	R31, R32	SMD 0805	1%, 100 mW, Thick Film SMD Resistor
1	243Ω	R33	SMD 0805	1%, 100 mW, Thick Film SMD Resistor
1	715Ω	R34	SMD 0805	1%, 100 mW, Thick Film SMD Resistor
2	option	R38, R39	SMD 0805	1%, 100 mW, Thick Film SMD Resistor
2	RC NTWK	RC1, RC2	SMD EZAST32	Panasonic 100 Ω/47pF Chip RC Network
2	10kΩ NTWK	RT1, RT2	SMD EXBE 10	Panasonic 10 kΩ Chip Resistor Network
1	SPDIF INPUT	J1	PCB Thru Hole	Right Angle PCB Mount RCA Jack
1	EXT DATA INTERFACE	J2	2×5, 0.1" PCB Thru Hole	10-Pin Vertical Shrouded Header
1	SPI CONTROL PORT	J3	2×5, 0.1" PCB Thru Hole	10-Pin Vertical Shrouded Header
1	ISP PORT	J4	2×5, 0.1" PCB Thru Hole	10-Pin Vertical Shrouded Header
1	PC PORT	J5	DB9 PCB Thru Hole	Right Angle, 9-Pin Male D-Sub Connector
1	LEFT OUT	J6	PCB Thru Hole	Right Angle PCB Mount RCA Jack
1	RIGHT OUT	J7	PCB Thru Hole	Right Angle PCB Mount RCA Jack
1	+9 to +12VDC	J8	PCB Thru Hole	RED, Screw Terminal/Banana Post
1	DGND	J9	PCB Thru Hole	BLK, Screw Terminal/Banana Post
1	+12VDC	J10	PCB Thru Hole	ORG, Screw Terminal/Banana Post
1	AGND	J11	PCB Thru Hole	GRN, Screw Terminal/Banana Post
1	-12VDC	J12	PCB Thru Hole	BLU, Screw Terminal/Banana Post
1	SELECT	JP1	3×2, 0.1", PCB Thru Hole	6-Pin Vertical Header

EVAL-AD1852EB

Qty. Used	Part Type	Designator	Footprint	Description
31	SPDIF/TOSLINK	S1	PCB Thru Hole	Right Angle Mount DPDT Slide Switch
1	MUTE	S2	2x5, 0.1" PCB Thru Hole	10-Pin Vertical Shrouded Header
1	SPDIF/EXT	S3	PCB Thru Hole	Vertical Slide SPST Switch
1	DEEMPH	S4	PCB Thru Hole	Vertical Slide SPST Switch
1	INTERFACE MODE	S5	PCB Thru Hole	8-Position, OCTAL Code, PCB Binary Switch
1	RESET	S6	SMD	Normally Open Push Button Switch
1	TORX173	U1	PCB Thru Hole	TOSLink Digital Audio Fibre Optic Receiver
1	CS8414-CS	U2	SOIC-28L	AES/EBU Digital Audio Interface Receiver
1	AD1852JRS	U3	28-LEAD SSOP	High Performance 24-BIT, 192kHz, Stereo DAC
1	M4-64/32-15VC	U4	TQFP-44	Vantis, MACH-4 Series ISP CPLD
1	74HC14M	U5	SO-14	Schmitt Trigger Hex Inverter
1	LM317MDT	U6	DPAK	Adjustable, 3-Term Voltage Regulator
1	ADP3303AR-5	U7	SO-8	Low Noise, Low Drop Out, Five Volt Regulator
1	ADM811TART	U8	SOT-143	200ms, Power-Up/Manual Reset Generator
1	OP275GS	U9	SO-8	High Performance Audio Op Amp
2	74HC00M	U10, U11	SO-14	Quad 2-Input Nand Gate

C00738-2.5-1/01 (rev. 0)

PRINTED IN U.S.A.