



## 96-kHz, 24-Bit Digital Audio Interface Receiver

### FEATURES

- One-Chip Digital Audio Interface Receiver (DIR) Including Low-Jitter Clock-Recovery System
- Compliant With Digital Audio Interface Standards: IEC60958 (former IEC958), JEITA CPR-1205 (former EIAJ CP-1201, CP-340), AES3, EBU tech3250
- Clock Recovery and Data Decode From Biphase Input Signal, Generally Called S/PDIF, EIAJ CP-1201, IEC60958, AES/EBU
- Biphase Input Signal Sampling Frequency ( $f_s$ ) Range: 28 kHz to 108 kHz
- Low-Jitter Recovered System Clock: 50 ps
- Jitter Tolerance Compliant With IEC60958-3
- Selectable Recovered System Clock: 128  $f_s$ , 256  $f_s$ , 384  $f_s$ , 512  $f_s$
- Serial Audio Data Output Formats: 24-Bit I<sup>2</sup>S; MSB-First, 24-Bit Left-Justified; MSB-First 16-, 24-Bit Right-Justified
- User Data, Channel-Status Data Outputs Synchronized With Decoded Serial Audio Data
- No External Clock Required for Decode
- Includes Actual Sampling Frequency Calculator (Needs External 24.576-MHz Clock)
- Function Control: Parallel (Hardware)
- Functions Similar and Pin Assignments Equivalent to Those of DIR1703
- Single Power Supply: 3.3 V (2.7 V to 3.6 V)
- Wide Operating Temperature Range: –40°C to 85°C
- 5 V-Tolerant Digital Inputs
- Package: 28-pin TSSOP, Pin Pitch: 0,65 mm

### APPLICATIONS

- AV/DVD Receiver, AV Amplifier
- Car or Mobile Audio System
- Digital Television
- Musical Instruments
- Recording Systems
- High-End Audio/Sound Card for PC
- Replacement of DIR1703
- Other Applications Requiring S/PDIF Receiver

### DESCRIPTION

The DIR9001 is a digital audio interface receiver that can receive a 28-kHz to 108-kHz sampling-frequency, 24-bit-data-word, biphase-encoded signal. The DIR9001 complies with IEC60958-3, JEITA CPR-1205 (Revised version of EIAJ CP-1201), AES3, EBUtech3250, and it can be used in various applications that require a digital audio interface.

The DIR9001 supports many output system clock and output data formats and can be used flexibly in many application systems. As the all functions which the DIR9001 provides can be controlled directly through control pins, it can be used easily in an application system that does not have a microcontroller. Also, as dedicated pins are provided for the channel-status bit and user-data bit, processing of their information can be easily accomplished by connecting with a microcontroller, DSP, etc.

The DIR9001 does not require an external clock source or resonator for decode operation if the internal actual-sampling-frequency calculator is not used. Therefore, it is possible to reduce the cost of a system.

The operating temperature range of the DIR9001 is specified as –40°C to 85°C, which makes it suitable for automotive applications.



Please be aware that an important notice concerning availability, standard warranty, and use in critical applications of Texas Instruments semiconductor products and disclaimers thereto appears at the end of this data sheet.

SpAct is a trademark of Texas Instruments.

All other trademarks are the property of their respective owners.



This integrated circuit can be damaged by ESD. Texas Instruments recommends that all integrated circuits be handled with appropriate precautions. Failure to observe proper handling and installation procedures can cause damage.

ESD damage can range from subtle performance degradation to complete device failure. Precision integrated circuits may be more susceptible to damage because very small parametric changes could cause the device not to meet its published specifications.

## ABSOLUTE MAXIMUM RATINGS

over operating free-air temperature range (unless otherwise noted) <sup>(1)</sup>

		VALUE	UNIT
V <sub>CC</sub>	Supply voltage	−0.3 to 4	V
V <sub>DD</sub>			
V <sub>CC</sub> to V <sub>DD</sub>	Supply voltage differences	±0.1	V
AGND to DGND	Ground voltage differences	±0.1	V
Digital input voltage	Digital input	−0.3 to 6.5	V
	Digital output	−0.3 to (V <sub>DD</sub> + 0.3) < 4	
Analog input voltage	XTI, XTO	−0.3 to (V <sub>CC</sub> + 0.3) < 4	V
	FILT	−0.3 to (V <sub>CC</sub> + 0.3) < 4	
Input current (any pins except supplies)		±10	mA
Ambient temperature under bias		−40 to 125	°C
Storage temperature		−55 to 150	°C
Junction temperature		150	°C
Lead temperature (soldering)		260	°C, 5 s
Package temperature (reflow, peak)		260	°C

(1) Stresses beyond those listed under *absolute maximum ratings* may cause permanent damage to the device. These are stress ratings only and functional operation of the device at these or any other conditions beyond those indicated under *recommended operating conditions* is not implied. Exposure to absolute-maximum-rated conditions for extended periods may affect device reliability.

## RECOMMENDED OPERATING CONDITIONS

over operating free-air temperature range (unless otherwise noted)

		MIN	NOM	MAX	UNIT
V <sub>CC</sub>	Analog supply voltage	2.7	3.3	3.6	VDC
V <sub>DD</sub>	Digital supply voltage	2.7	3.3	3.6	VDC
Digital input clock frequency	XTI is connected to clock source	24.576			MHz
	XTI is connected to DGND	Not required			MHz
Digital output load capacitance, except SCKO		20			pF
Digital output load capacitance (SCKO)		10			pF
T <sub>A</sub>	Operating free-air temperature	−40	85		°C

## ELECTRICAL CHARACTERISTICS

All specifications at  $T_A = 25^\circ\text{C}$ ,  $V_{DD} = V_{CC} = 3.3\text{ V}$  (unless otherwise noted)

PARAMETER		TEST CONDITIONS	MIN	TYP	MAX	UNIT
<b>DIGITAL INPUT/OUTPUT CHARACTERISTICS</b>						
$V_{IH}$	Input logic level <sup>(1)</sup>		$0.7 V_{DD}$		$V_{DD}$	VDC
$V_{IL}$					$0.3 V_{DD}$	
$V_{IH}$	Input logic level <sup>(2)</sup>		2		5.5	VDC
$V_{IL}$					0.8	
$V_{OH}$	Output logic level <sup>(3)</sup>	$I_O = 4\text{ mA}$	$0.85 V_{DD}$			VDC
$V_{OL}$		$I_O = -4\text{ mA}$			$0.15 V_{DD}$	
$I_{IH}$	Input leakage current <sup>(4)</sup>	$V_{IN} = V_{DD}$		65	100	$\mu\text{A}$
$I_{IL}$		$V_{IN} = 0\text{ V}$	-10		10	
$I_{IH}$	Input leakage current <sup>(5)</sup>	$V_{IN} = V_{DD}$	-10		10	$\mu\text{A}$
$I_{IL}$		$V_{IN} = 0\text{ V}$	-100	-65		
$I_{IH}$	Input leakage current <sup>(6)</sup>	$V_{IN} = V_{DD}$	-10		10	$\mu\text{A}$
$I_{IL}$		$V_{IN} = 0\text{ V}$	-10		10	
<b>BIPHASE SIGNAL INPUT AND PLL</b>						
Input sampling frequency range			28		108	kHz
Jitter tolerance — (IEC60958-3)		IEC60958-3 (2003-01)	Compliant			
PLL lock-up time		From biphasic signal detection to error-out release (ERROR = L)			100	ms
<b>RECOVERED CLOCK AND DATA</b>						
Serial audio data width			16		24	Bit
SCKO frequency	128 $f_S$		3.584		13.824	MHz
	256 $f_S$		7.168		27.648	
	384 $f_S$		10.752		41.472	
	512 $f_S$		14.336		55.296	
BCKO frequency		64 $f_S$	1.792		6.912	MHz
LRCKO frequency		$f_S$	28		108	kHz
SCKO jitter		$f_S = 48\text{ kHz}$ , SCKO = 256 $f_S$ , measured periodic		50	100	ps rms
SCKO duty cycle			45%		55%	
<b>XTI SOURCE CLOCK</b>						
XTI source clock frequency	XTI is connected to clock source		24.576			MHz
	XTI is connected to DGND		Not required			
Frequency accuracy		XTI is connected to clock source	-100		100	ppm
XTI input-clock duty cycle		XTI is connected to clock source	45%		55%	
<b>POWER SUPPLY AND SUPPLY CURRENT</b>						
$V_{CC}$	Operation voltage range		2.7	3.3	3.6	VDC
$V_{DD}$			2.7	3.3	3.6	

(1) CMOS compatible input: XTI (not 5-V tolerant)

(2) 5-V tolerant TTL inputs: RXIN, FMT0, FMT1, PSCK0, PSCK1, CKSEL, RST, RSV

(3) CMOS outputs: XTO, SCKO, BCKO, LRCKO, DOUT, UOUT, COUT, BFRAME, ERROR, CLKST, AUDIO, EMPH, FSOUT0, FSOUT1

(4) Internal pulldowns: FMT0, FMT1, PSCK0, PSCK1, CKSEL, RSV

(5) Internal pullup: RST

(6) No internal pullup and pulldown: RXIN, XTI

## ELECTRICAL CHARACTERISTICS (continued)

All specifications at  $T_A = 25^\circ\text{C}$ ,  $V_{DD} = V_{CC} = 3.3\text{ V}$  (unless otherwise noted)

PARAMETER	TEST CONDITIONS	MIN	TYP	MAX	UNIT
$I_{CC}$ Supply current <sup>(7)</sup>	$f_S = 96\text{ kHz}$ , PLL locked, XTI connected to DGND		6	8.3	mA
	$f_S = 96\text{ kHz}$ , PLL locked, XTI connected to 24.576-MHz resonator		6	8.3	mA
	RXIN = H or L, XTI = L, $\overline{\text{RST}} = \text{L}$		130		$\mu\text{A}$
$I_{DD}$ Supply current <sup>(7)</sup>	$f_S = 96\text{ kHz}$ , PLL locked, XTI connected to DGND		6	8.3	mA
	$f_S = 96\text{ kHz}$ , PLL locked, XTI connected to 24.576-MHz resonator		9	12.4	mA
	RXIN = H or L, XTI = L, $\overline{\text{RST}} = \text{L}$		72		$\mu\text{A}$
$P_D$ Power dissipation <sup>(7)</sup>	$f_S = 96\text{ kHz}$ , PLL locked, XTI connected to DGND		40	55	mW
	$f_S = 96\text{ kHz}$ , PLL locked, XTI connected to 24.576-MHz resonator		50	68	mW
	RXIN = H or L, XTI = L, $\overline{\text{RST}} = \text{L}$		0.67		mW
<b>TEMPERATURE RANGE</b>					
$T_A$ Operation temperature range		–40		85	$^\circ\text{C}$
$\theta_{JA}$ Thermal resistance	28-pin T-SSOP		105		$^\circ\text{C/W}$

(7) No load connected to SCKO, BCKO, LRCKO, DOUT, COUT, VOUT, BFRAME, FSOUT0, FSOUT1, CLKST, ERROR, EMPH,  $\overline{\text{AUDIO}}$

## PIN ASSIGNMENTS

DIR9001  
(TOP VIEW)

1	AUDIO $\overline{\text{O}}$	CKSEL	28
2	FSOUT0	ERROR	27
3	FSOUT1	FMT1	26
4	SCKO	FMT0	25
5	$V_{DD}$	$V_{CC}$	24
6	DGND	AGND	23
7	XTO	FILT	22
8	XTI	$\overline{\text{RST}}$	21
9	CLKST	RXIN	20
10	LRCKO	RSV	19
11	BCKO	BFRAME	18
12	DOUT	EMPH	17
13	PSCK0	UOUT	16
14	PSCK1	COUT	15

**TERMINAL FUNCTIONS**

TERMINAL		I/O	PULL UP/DOWN	REMARKS	DESCRIPTION
NAME	NO.				
AGND	23	–			Analog ground
$\overline{\text{AUDIO}}$	1	OUT		CMOS	Channel-status data information of non-audio sample word, active-low
BCKO	11	OUT		CMOS	Audio data bit clock output
BFRAME	18	OUT		CMOS	Indication of top block of biphasic input signal
CKSEL	28	IN	Pulldown	5-V tolerant TTL	Selection of system clock source, Low: PLL (VCO) clock, High: XTI clock <sup>(1)</sup>
CLKST	9	OUT		CMOS	Clock change/transition signal output
COUT	15	OUT		CMOS	Channel-status data serial output synchronized with LRCKO
DGND	6	–			Digital ground
DOUT	12	OUT		CMOS	16-bit/24-bit decoded serial digital audio data output
EMPH	17	OUT		CMOS	Channel-status data information of pre-emphasis (50 $\mu$ s/15 $\mu$ s)
ERROR	27	OUT		CMOS	Indication of internal PLL or data parity error
FILT	22	–			External filter connection terminal; must connect recommended filter.
FMT0	25	IN	Pulldown	5-V tolerant TTL	Decoded serial digital audio data output format selection 0 <sup>(1)</sup>
FMT1	26	IN	Pulldown	5-V tolerant TTL	Decoded serial digital audio data output format selection 1 <sup>(1)</sup>
FSOUT0	2	OUT		CMOS	Actual sampling frequency calculated result output 0
FSOUT1	3	OUT		CMOS	Actual sampling frequency calculated result output 1
LRCKO	10	OUT		CMOS	Audio data latch enable output
PSCK0	13	IN	Pulldown	5-V tolerant TTL	PLL source SCKO output frequency selection 0 <sup>(1)</sup>
PSCK1	14	IN	Pulldown	5-V tolerant TTL	PLL source SCKO output frequency selection 1 <sup>(1)</sup>
$\overline{\text{RST}}$	21	IN	Pullup	5-V tolerant TTL	Reset control input, active-low <sup>(2)</sup>
RSV	19	IN	Pulldown		Reserved, must be connected to DGND <sup>(1)</sup>
RXIN	20	IN		5-V tolerant TTL	Biphase digital data input <sup>(3)</sup>
SCKO	4	OUT		CMOS	System clock output
UOUT	16	OUT		CMOS	User data serial output synchronized with LRCKO
V <sub>CC</sub>	24	–			Analog power supply, 3.3-V
V <sub>DD</sub>	5	–			Digital power supply, 3.3-V
XTI	8	IN		CMOS Schmitt-trigger	Oscillation amplifier input, or external XTI source clock input
XTO	7	OUT		CMOS	Oscillation amplifier output

(1) TTL Schmitt-trigger input with internal pulldown (51 k $\Omega$  typical), 5-V tolerant

(2) TTL Schmitt-trigger input with internal pullup (51 k $\Omega$  typical), 5-V tolerant

(3) TTL Schmitt-trigger input, 5-V tolerant.

**BLOCK DIAGRAM**

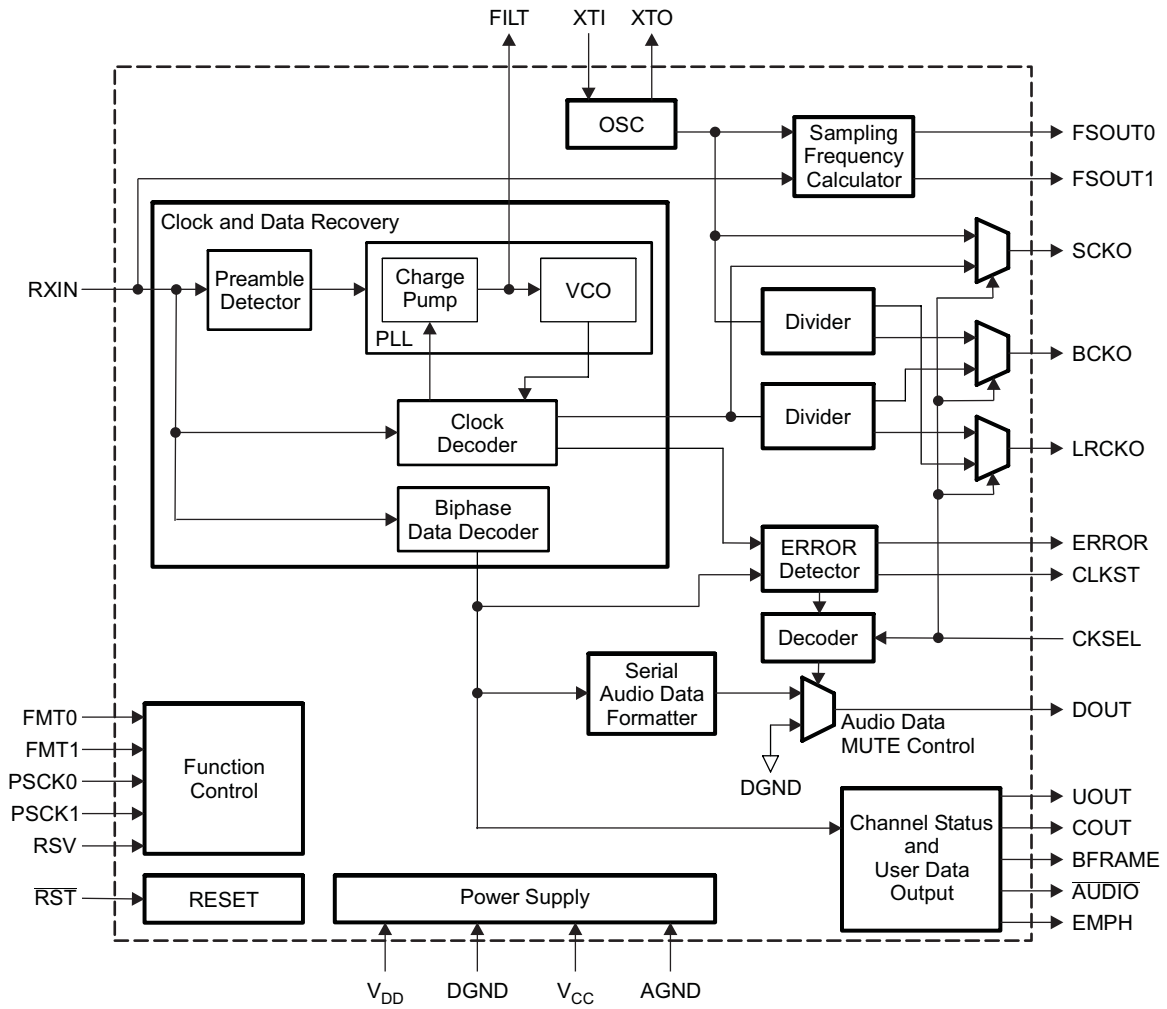

## TYPICAL PERFORMANCE CHARACTERISTICS

Oscillation amplifier operating with crystal; 1-kHz, 0-dB, sine-wave data; no load

### POWER SUPPLY CURRENT

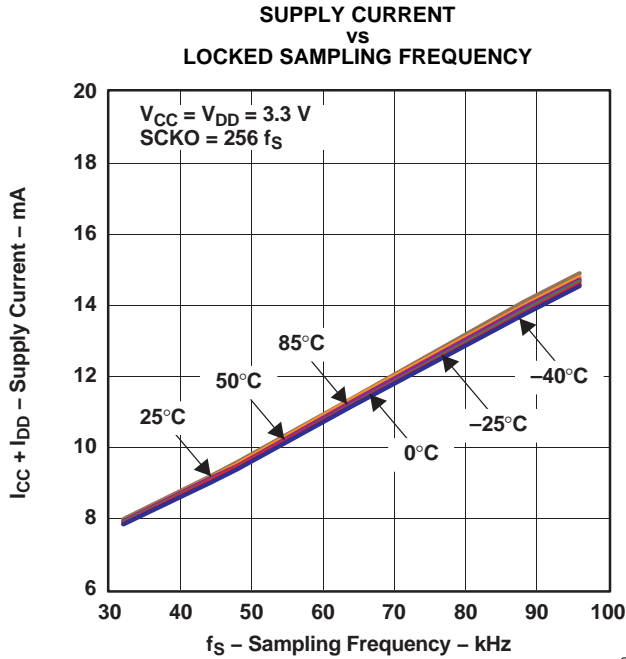

Figure 1.

G001

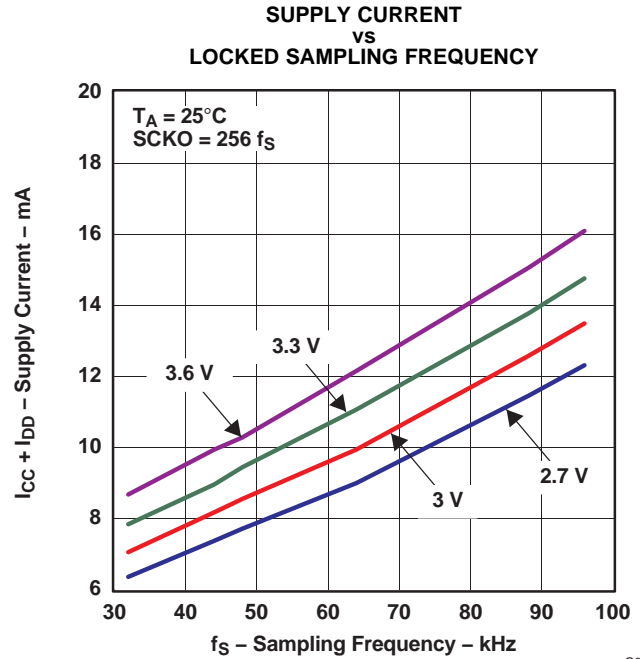

Figure 2.

G002

### RECOVERED SYSTEM CLOCK (SCKO) JITTER

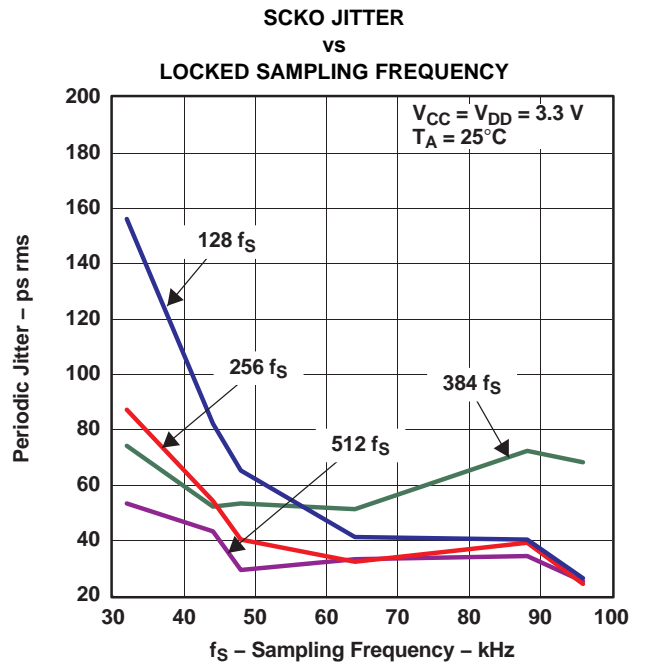

Figure 3.

G003

---

## DEVICE INFORMATION

### ACCEPTABLE BIPHASE INPUT SIGNAL AND BIPHASE INPUT PIN (RXIN)

The DIR9001 can decode the biphase signal format which is specified in one of the following standards. Generally, these following standards may be called Sony/Philips digital interface format (S/PDIF) or AES/EBU.

- IEC60958 (revised edition of former IEC958)
- JEITA CPR-1205 (revised edition of former EIAJ CP-1201, CP-340)
- AES3
- EBU tech3250

The sampling frequency range and data word length which DIR9001 can decode is as follows:

- Sampling frequency range is 28 kHz to 108 kHz.
- Maximum audio sample word length is 24-bit.

Note of others about the biphase input signal.

- The capture ratio of the built-in PLL complies with level III of sampling frequency accuracy ( $\pm 12.5\%$ ), which is specified in IEC60958-3.
- The jitter tolerance of the DIR9001 complies with IEC60958-3.
- The PLL may also lock in outside of the specified sampling-frequency range, but extended range is not assured.

Notice about the signal level and transmission line of the biphase input signal.

- The signal level and the transmission line (optical, differential, single-ended) are different in each standard.
- The biphase input signal is connected to the RXIN pin of the DIR9001.
- The RXIN pin has a 5-V tolerant TTL-level input.
- An optical receiver module (optical to electric converter) such as TOSLINK, which is generally used in consumer applications, is connected directly to the RXIN pin without added external components.
- The output waveform of the optical receiver module varies depending on the characteristics of each product type, so a dumping resistor or buffer amplifier might be required between the optical receiver module output and the DIR9001 input. Careful handling is required if the optical receiver module and the DIR9001 are separated by a long distance.
- The DIR9001 needs an external amplifier if it is connected to a coaxial transmission line.
- The DIR9001 needs an external differential to single-ended converter, attenuator, etc., for general consumer applications if non-optical transmission line is used.



**DEVICE INFORMATION (continued)**

**SYSTEM RESET**

The DIR9001 reset function is controlled by an external reset pin,  $\overline{\text{RST}}$ .

The reset operation must be performed during the power-up sequence as shown in Figure 4. Specifically, the DIR9001 requires reset operation with a 100-ns period after the supply voltage rises above 2.7 V.

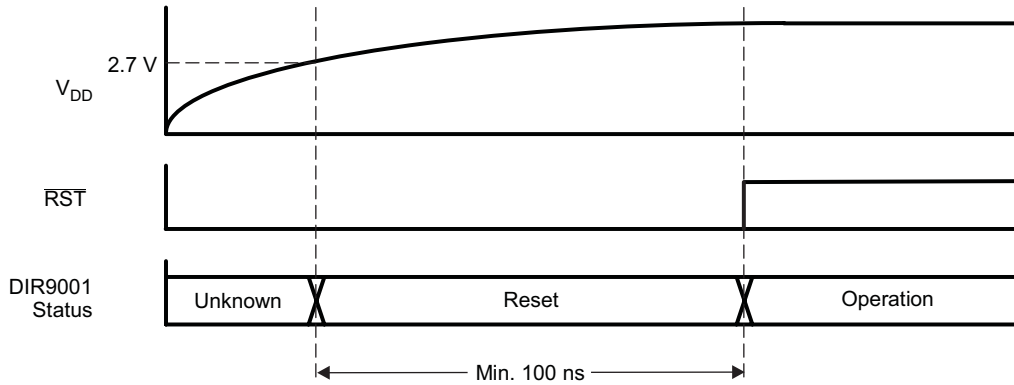

**Figure 4. Required System Reset Timing**

The state of each output pins during reset is shown in Table 1.

**Table 1. Output-Pin States During Reset Period**

CLASSIFICATION	PIN NAME	WHILE $\overline{\text{RST}} = \text{L}$
Clock	BCKO	L
	LRCKO	L
	SCKO	L
Data	DOUT	L
Flag and status	$\overline{\text{AUDIO}}$	L
	BFRAME	L
	CLKST	L
	COUT	L
	EMPH	L
	ERROR	H
	FSOUT0	L
FSOUT1	L	
Oscillation amplifier	UOUT	L
	XTO	Output

## OPERATION MODE AND CLOCK TRANSITION SIGNAL OUT

### Operation Mode

The DIR9001 has the following three operation modes.

These modes are selected by the connection of the CKSEL pin.

- PLL MODE: For demodulating a biphasic input signal; always outputs PLL source clock
- XTI MODE: For clock generator; always outputs XTI source clock
- AUTO MODE: Automatic clock source selection; output source depends on ERROR pin.

Notes about operation mode selection:

- Normally, the PLL mode: CKSEL = L is selected to decode a biphasic input signal.
- The XTI mode is a mode that supplies the XTI source clock to peripheral devices (A/D converters, etc); therefore, recovered clock and decoded data is not output.
- When the XTI source is not used, an XTI source is not required. In this case, clocks are not output in the XTI mode.
- At the time of XTI mode selection, biphasic decode function continues to operate. Therefore, the biphasic input status (ERROR) and the result of the sampling frequency calculator (a required XTI source for operation), are always monitored. That is, the following output pins: ERROR, BFRAME, FSOUT[1:0], CLKST, AUDIO and EMPH are always enabled.

The details of these three modes are given in [Table 2](#).

**Table 2. Operation Mode and Clock Source**

OPERATION MODE	CKSEL PIN SETTING	ERROR PIN STATUS	SCKO, BCKO, LRCKO CLOCK SOURCE	DOUT DATA	<u>AUDIO</u> EMPH	FSOUT [1:0]	BFRAME	COUT UOUT
PLL	L	H	PLL (VCO) free-running clock <sup>(1)</sup>	MUTE (Low)	LOW	HL	LOW	LOW
		L	PLL recovered clock	Decoded data	OUT	OUT	OUT	OUT
XTI	H	H	XTI clock	MUTE (Low)	LOW	HL	LOW	LOW
		L	XTI clock	MUTE (Low)	OUT	OUT	OUT	LOW
AUTO	Connected to ERROR pin	H	XTI clock	MUTE (Low)	LOW	HL	LOW	LOW
		L	PLL recovered clock	Decoded data	OUT	OUT	OUT	OUT

(1) The VCO free-running frequency is not a constant frequency, because the VCO oscillation frequency is dependent on supply voltage, temperature, and process variations.

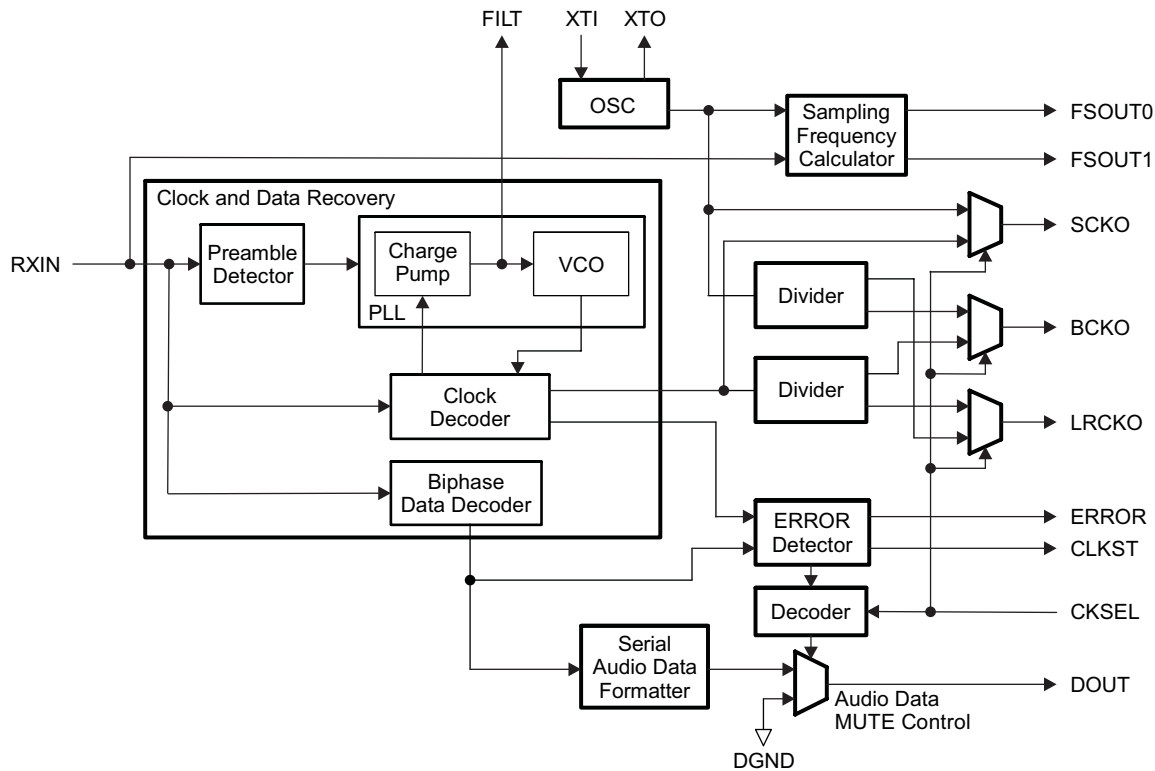

**Figure 5. Clock Source, Source Selector, and Data Path**

### Clock Transition Signal Out

The DIR9001 provides an output pulse that is synchronized with the PLL's LOCK/UNLOCK status change.

The CLKST pin outputs the PLL status change between LOCK and UNLOCK. The CLKST output pulse depends only on the status change of the PLL.

This clock change/transition signal is output through CLKST.

As this signal indicates a clock transition period due to a PLL status change, it can be used for muting or other appropriate functions in an application.

A clock source selection caused by the CLKSEL pin does not affect the output of CLKST.

CLKST does change due to PLL status change even if CKSEL = H in the XTI source mode.

When DIR9001 is reset in the state where it is locked to the biphase input signal, the pulse signal of CLKST is not output. That is, the priority of reset is higher than CLKST.

The relation among the lock-in/unlock process, the CLKST and ERROR outputs, the output clocks (SCKO, BCKO, LRCKO), and data (DOUT) is shown in [Figure 6](#).

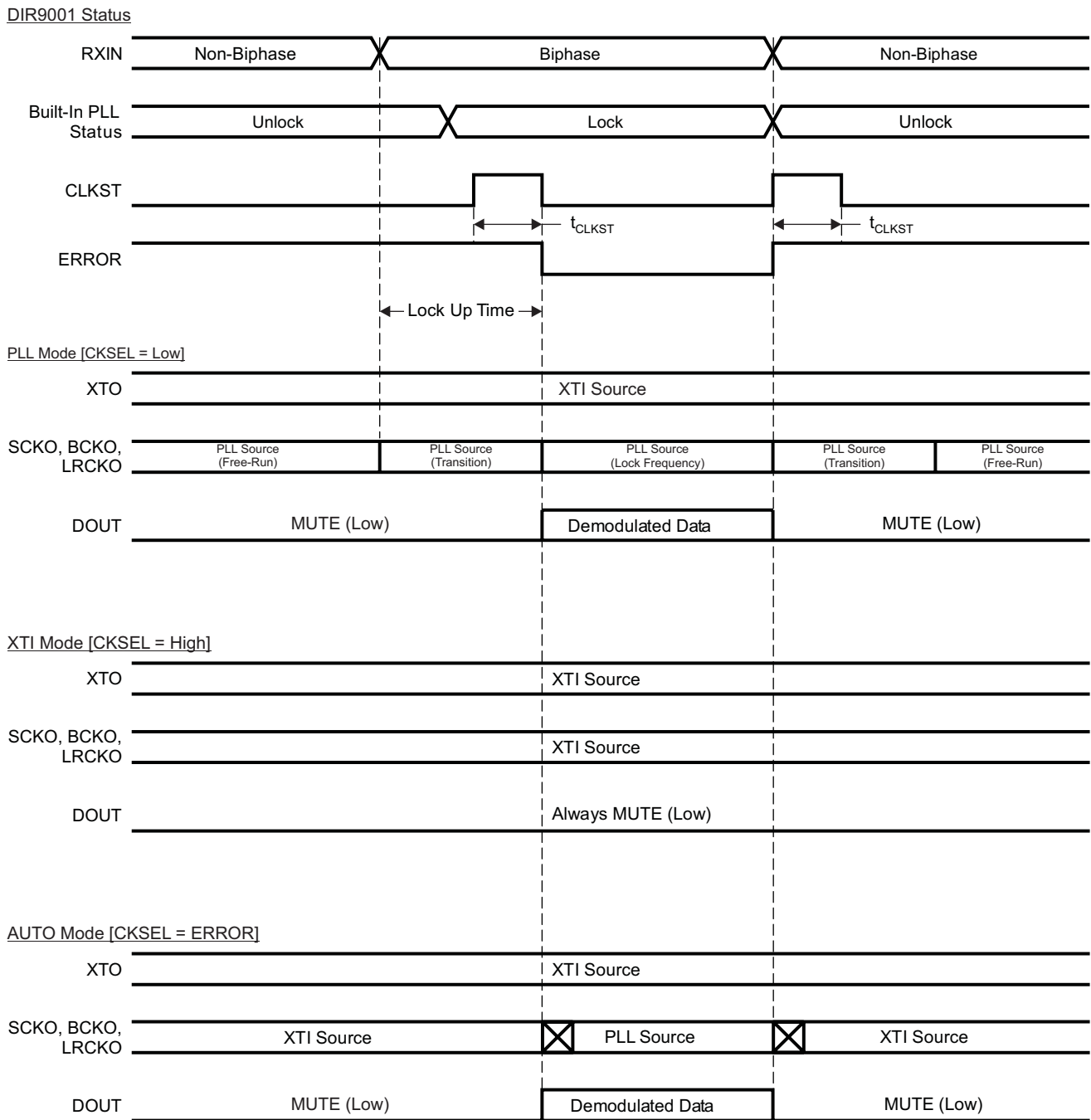

Note: ☒ means clock source change.

PARAMETERS		MIN	TYP	MAX	UNIT
$t_{CLKST}$	CLKST pulse duration, high	4		20	$\mu s$

Figure 6. Lock-In and Unlock Process

## CLOCK DESCRIPTION

### System Clock Source

DIR9001 has the following two clock sources for the system clock.

- PLL source (128  $f_S$ , 256  $f_S$ , 384  $f_S$ , 512  $f_S$  are available, recovered by built-in PLL)
- XTI source (One 24.576-MHz resonator or external clock source is required.)

Two clock sources are used for the following purpose.

- PLL source: Recovered system clock from the biphase input signal
- XTI source: Clock source for peripheral devices (for example, A/D converter, microcontroller, etc.)  
Measurement reference clock for the internal actual-sampling-frequency calculator

Description of PLL clock source

- The PLL clock source is the output clock of built-in PLL (including VCO).
- The PLL clock source frequency is selectable from 128  $f_S$ , 256  $f_S$ , 384  $f_S$ , 512  $f_S$  by PSCK[1:0].
- When the PLL is in the locked condition, the PLL clock source is the clock recovered from the biphase input signal.
- When PLL is in the unlocked condition, the PLL clock source is the built-in free-running clock of the VCO.
- The frequency of the PLL clock source in the unlocked condition is not constant.  
(The VCO free-running frequency is dependent on supply voltage, temperature, and variations in the die's wafer.)

Description of XTI clock source

- The XTI clock source is not used to recover the clock and decode data from the biphase input signal.
- Therefore, if the DIR9001 is used only for recovering the clock and decoding data from the biphase input signal, an XTI clock source is not required. In this case, the XTI pin must be connected to the DGND pin.  
(The DIR9001 does not have a selection pin for using an XTI clock source or not using one.)

The selection method of clock source

- The output clock is selected from two clock sources by the level of the CKSEL pin.
- The selection of the system clock source depends only on the input level of CKSEL pin.
- CKSEL = L setting is required for recovering the clock and decoding data from biphase input.
- CKSEL = H setting is required for XTI clock source output.
- The continuity of clock during the clock source transition between the XTI source and the PLL source is not assured.

Method of automatic clock source selection (CLOCK SOURCE MODE: AUTO)

- This method enables selection of the clock source automatically, using the DIR9001 ERROR status. The PLL source clock is output when ERROR = L; the XTI source is output when ERROR = H.
- To enable automatic clock source selection, the CKSEL pin must be connected to the ERROR pin.
- If XTI clock source is needed during the ERROR period, this method is recommended.
- Because the clock source during ERROR status is XTI, if an XTI clock source is not provided to the XTI pin, then SCKO, BCKO, and LRCKO are not output during the ERROR period.

The relationship between the clock/data source and the combination of CKSEL pin and PLL status inputs is shown in [Table 2](#).

The clock tree system is shown in [Figure 7](#).

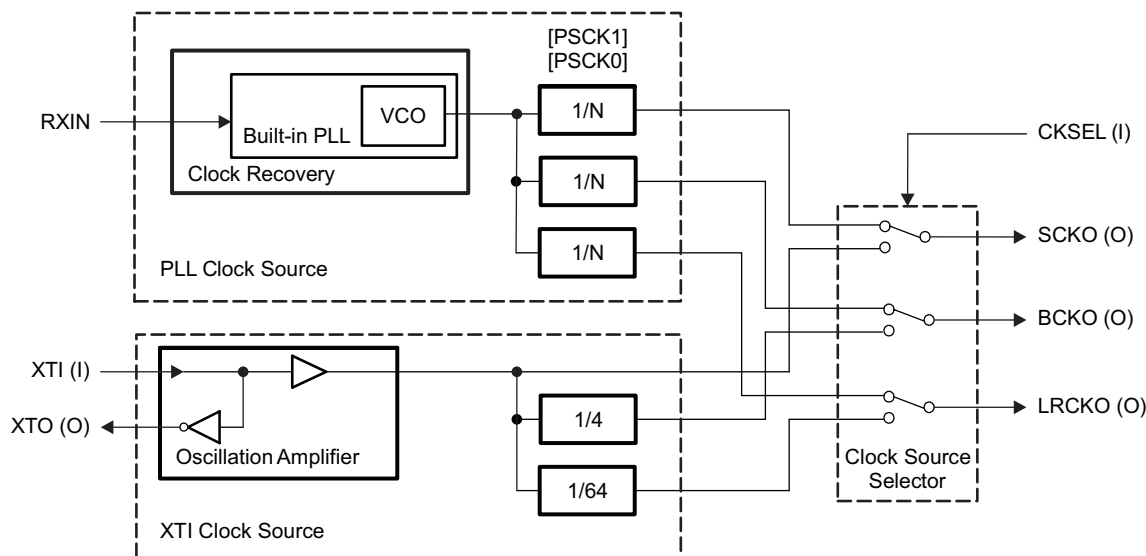

**Figure 7. Clock Tree Diagram**

### PLL Clock Source (Built-In PLL and VCO) Description

The DIR9001 has on-chip PLL (including VCO) for recovering the clock from the biphasic input signal.

The clock that is output from the built-in VCO is defined as the PLL clock source.

In the locked state, the built-in PLL generates a system clock that synchronizes with the biphasic input signal.

In the unlocked state, the built-in PLL (VCO) generates a free-running clock. (The frequency is not constant.)

The PLL can support a system clock of  $128 f_s$ ,  $256 f_s$ ,  $384 f_s$ , or  $512 f_s$ , where  $f_s$  is the sampling frequency of the biphasic input signal.

The system clock frequency of the PLL is selected by PSCK[1:0].

The DIR9001 can decode a biphasic input signal through its 28 sampling-frequency range of kHz to 108 kHz, independent of the setting of PSCK[1:0].

Therefore, the DIR9001 can decode a biphasic input signal with a sampling frequency from 28 kHz to 108 kHz at all settings of PSCK[1:0].

The relationship between the PSCK[1:0] selection and the output clock (SCKO, BCKO, LRCKO) from the PLL source is shown in [Table 3](#).

**Table 3. SCKO, BCKO, and LRCKO Frequencies Set by PSCK[1:0]**

PSCK[1:0] SETTING		OUTPUT CLOCK FROM PLL SOURCE		
PSCK1	PSCK0	SCKO	BCKO	LRCKO
L	L	$128 f_s$	$64 f_s$	$f_s$
L	H	$256 f_s$	$64 f_s$	$f_s$
H	L	$384 f_s$	$64 f_s$	$f_s$
H	H	$512 f_s$	$64 f_s$	$f_s$

In PLL mode (CKSEL = L), output clocks (SCKO, BCKO, LRCKO) are generated from the PLL source clock.

The relationship between frequencies of LRCKO, BCKO, and SCKO at different sampling frequencies  $f_s$  of the biphasic input signal are shown in [Table 4](#).

**Table 4. Output Clock Frequency in PLL Locked State (CKSEL = L)**

LRCKO	BCKO	SCKO (Depending on PSCK[1:0] Setting)				
		$f_s$	$64 f_s$	$128 f_s$	$256 f_s$	$384 f_s$
32 kHz	2.048 MHz	4.096 MHz	8.192 MHz	12.288 MHz	16.384 MHz	16.384 MHz
44.1 kHz	2.8224 MHz	5.6448 MHz	11.2896 MHz	16.9344 MHz	22.5792 MHz	22.5792 MHz
48 kHz	3.072 MHz	6.144 MHz	12.288 MHz	18.432 MHz	24.576 MHz	24.576 MHz
88.2 kHz	5.6448 MHz	11.2896 MHz	22.5792 MHz	33.8688 MHz	45.1584 MHz	45.1584 MHz
96 kHz	6.144 MHz	12.288 MHz	24.576 MHz	36.864 MHz	49.152 MHz	49.152 MHz

### Required PLL Loop Filter Description

The DIR9001 incorporates a PLL for generating a clock synchronized with the biphasic input signal.

The built-in PLL requires an external loop filter, which is specified as follows.

Operation and performance is assured for recommended filter components R1, C1, and C2.

Notes about Loop Filter Components and Layout

- The resistor and capacitors which comprise the filter should be located and routed as close as possible to the DIR9001.
- A carbon film resistor or metal film resistor, with tolerance less than 5%, is recommended.
- Film capacitors, with tolerance is less than 5%, is recommended.
- If ceramic capacitors are used for C1 and C2, parts with a low voltage coefficient and low temperature coefficient, such as CH or C0G, are recommended.
- The external loop filter must be placed on FILT pins.
- The GND node of the external loop filter must be directly connected with the AGND pin of the DIR9001; it must be not combined with other signals.

The configuration of external loop filter and the connection with the DIR9001 is shown in [Figure 8](#).

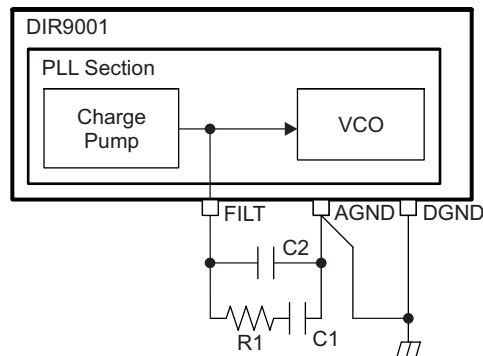

**Figure 8. Loop Filter Connection**

The recommended values of loop filter components is shown in [Table 5](#).

**Table 5. Recommended Value of Loop Filter Components**

REF. NO.	RECOMMENDED VALUE	PARTS TYPE	TOLERANCE
R1	680 $\Omega$	Metal film or carbon	$\leq 5\%$
C1	0.068 $\mu\text{F}$	Film or ceramic (CH or C0G)	$\leq 5\%$
C2	0.0047 $\mu\text{F}$	Film or ceramic (CH or C0G)	$\leq 5\%$

## XTI Clock Source and Oscillation Amplifier Description

This clock, driven by the built-in oscillation amplifier or input into the XTI pin from an external clock, is defined as the XTI source. A 24.576-MHz fundamental resonator or external 24.576-MHz clock is used as the XTI source.

The DIR9001 requires an XTI source for following purposes:

- The measurement reference clock of actual-sampling-frequency calculator
- The clock source for the XTI source mode (CKSEL = H setting)  
(That is, the DIR9001 does not require an XTI source if it is only decoding the biphasic input signal.)

The XTI clock source is supplied in one of the following two ways; the details are described in [Figure 9](#).

- Setting up an oscillation circuit by connecting a resonator with the built-in amplifier
- Applying a clock from an external oscillator circuit or oscillator module

To set up an oscillation circuit by connecting a resonator with the built-in amplifier:

- Connect a 24.576-MHz resonator between the XTI pin and XTO pin.
- The resonator should be a fundamental-mode type.
- A crystal resonator or ceramic resonator can be used.
- The load capacitor  $C_{L1}$ ,  $C_{L2}$ , and the current-limiting resistor  $R_d$  depend on the characteristics of the resonator.
- No external feedback resistor between the XTI pin and XTO pin is required, as an appropriate resistor is incorporated in the device.
- No load other than the resonator is allowed on the XTO pin.

To connect an external oscillator circuit or oscillator module:

- Provide a 24.576-MHz clock on the XTI pin
- Note that the XTI pin is not 5-V tolerant; it is simple CMOS input.
- The XTO pin must be open.

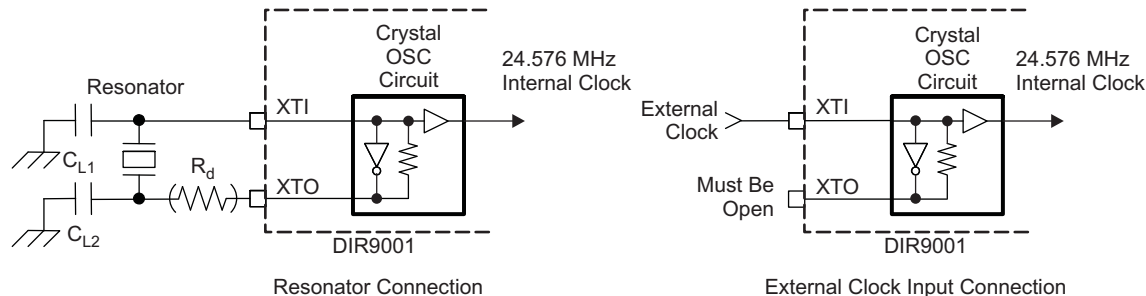

**Figure 9. XTI and XTO Connection Diagram**

Description of oscillation amplifier operation:

- The built-in oscillation amplifier is always working.
- If the XTI source clock is not used, then the XTI pin must be connected to DGND.
- For reducing power dissipation, it is recommended to not use the XTI source clock.

In XTI mode (CKSEL = H), output clocks (SCKO, BCKO, LRCKO) are generated from XTI source clock.

The relation between output clock frequency (SCKO, BCKO, LRCKO) and the XSCK pin setting in XTI source mode is shown in [Table 6](#).

**Table 6. SCKO, BCKO, LRCKO Output Frequency at XTI Mode**

XTI FREQUENCY	OUTPUT CLOCK FREQUENCY IN XTI SOURCE MODE (CKSEL = H)		
	SCKO	BCKO	LRCKO
24.576 MHz	24.576 MHz	6.144 MHz	96 kHz



## DATA DESCRIPTION

### Decoded Serial Audio Data Output and Interface Format

The DIR9001 supports following 4-data formats for the decoded data.

- 16-bit, MSB-first, right-justified
- 24-bit, MSB-first, right-justified
- 24-bit, MSB-first, left-justified
- 24-bit, MSB-first, I<sup>2</sup>S

Decoded data is MSB first and 2s-complement in all formats.

The decoded data is provided through the DOUT pin.

The format of the decoded data is selected by the FMT[1:0] pins.

The data formats for each FMT[1:0] pin setting are shown in [Table 7](#).

**Table 7. Serial Audio Data Output Format Set by FMT[1:0]**

FMT[1:0] SETTINGS		DOUT SERIAL AUDIO DATA OUTPUT FORMAT
FMT1	FMT0	
L	L	16-bit, MSB-first, right-justified
L	H	24-bit, MSB-first, right-justified
H	L	24-bit MSB-first, left-justified
H	H	24-bit, MSB-first, I <sup>2</sup> S

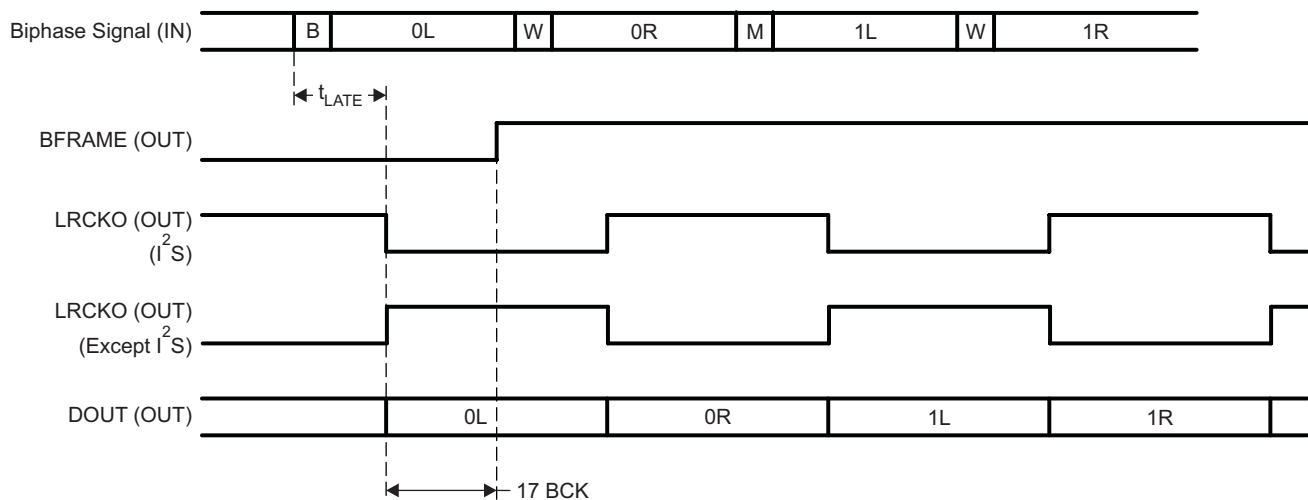

PARAMETERS		MIN	TYP	MAX	UNIT
$t_{LATE}$	LRCKO/DOUT latency		$3/f_s$		s

**Figure 10. Latency Time Between Biphase Input and LRCKO/DOUT**

The relationships among BCKO, LRCKO, and DOUT for each format are shown in Figure 11.

Right Justified (MSB First, 24-bit, 16-bit)

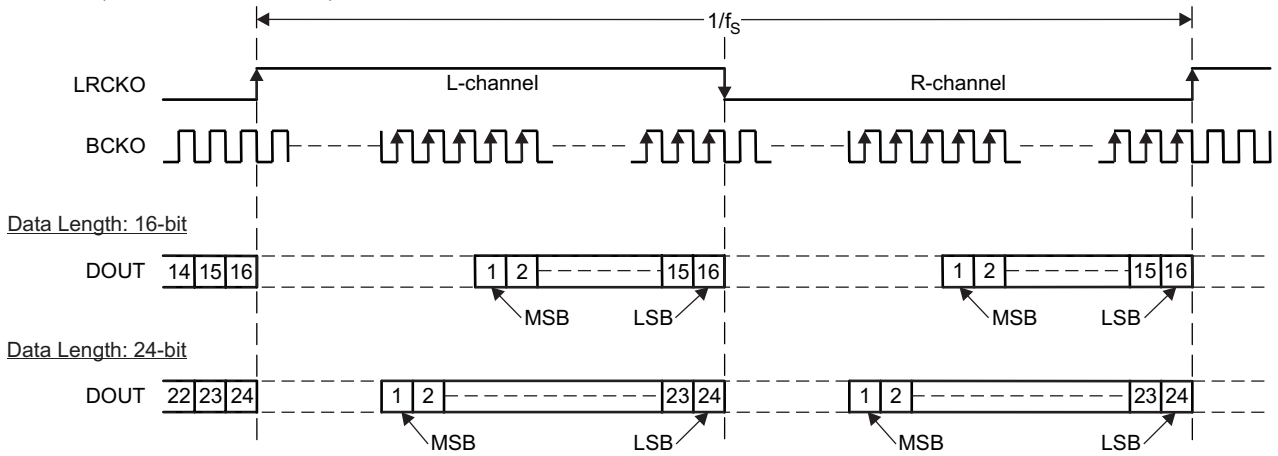

Left Justified (MSB First)

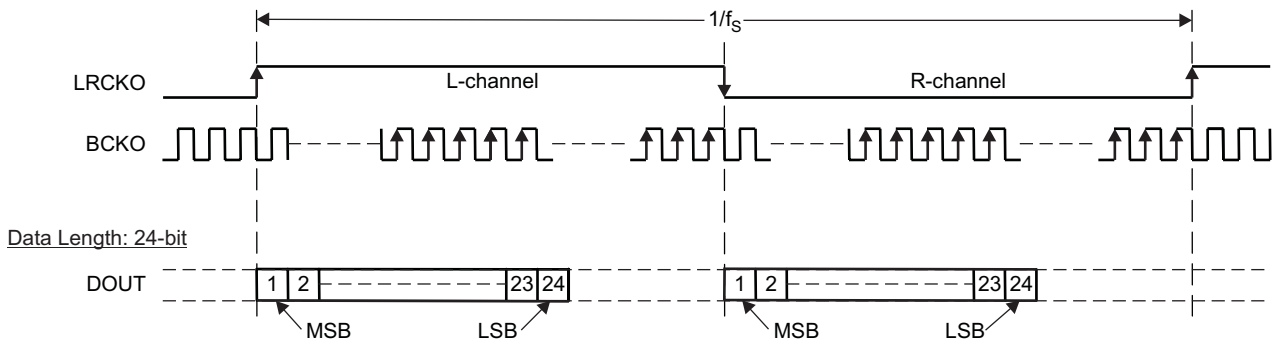

I<sup>2</sup>S Format (MSB First)

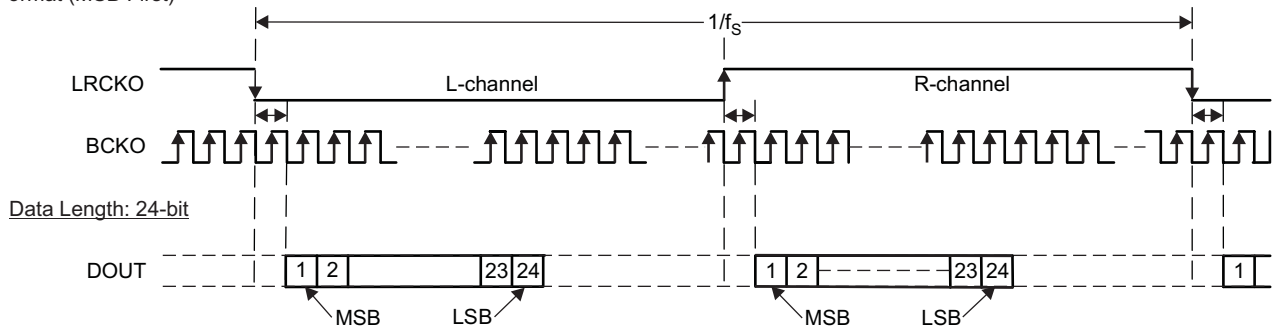
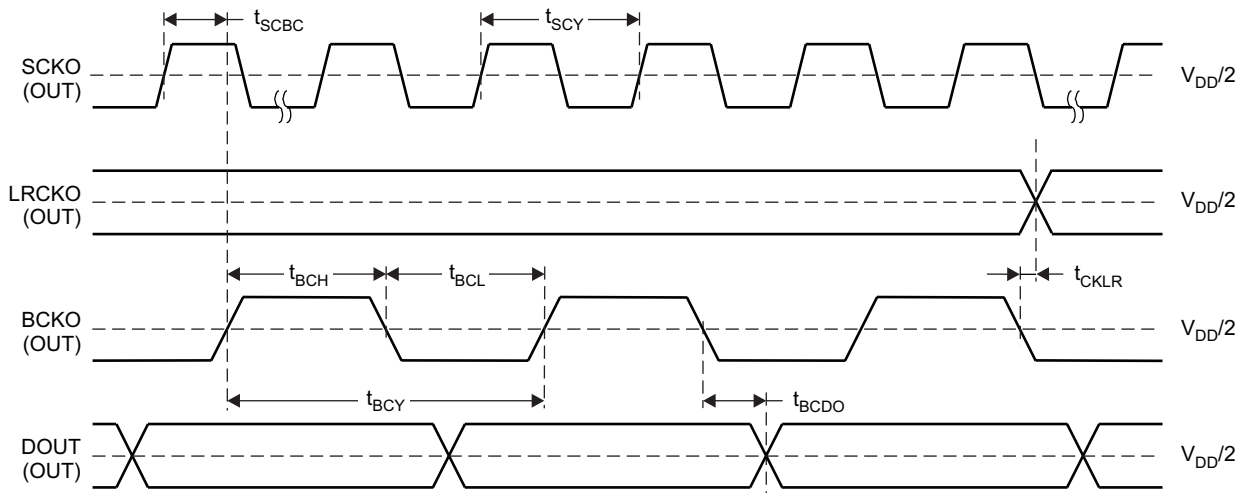

Figure 11. Decoded Serial Audio Data Output Formats



PARAMETERS		MIN	TYP	MAX	UNIT
$t_{SCY}$	System clock pulse cycle time	18			ns
$t_{SCBC}$	Delay time of SCK rising edge to BCK rising edge	4	8	15	ns
$t_{CKLR}$	Delay time of BCKO falling edge to LRCKO valid	-5	0.5	0.5	ns
$t_{BCY}$	BCKO pulse cycle time		$1/64f_s$		s
$t_{BCH}$	BCKO pulse duration, HIGH	60			ns
$t_{BCL}$	BCKO pulse duration, LOW	60			ns
$t_{BCDO}$	Delay time of BCKO falling edge to DOUT valid	-5	1	5	ns
$t_r$	Rising time of all signals			10	ns
$t_f$	Falling time of all signals			10	ns

NOTE: Load capacitance of the LRCKO, BCKO, and DOUT pins is 20 pF. DOUT, LRCKO, and BCKO are synchronized with SCKO.

**Figure 12. Decoded Audio Data Output Timing**

## Channel-Status Data and User Data Serial Outputs

The DIR9001 can output channel-status data and user data synchronized with audio data from the biphasic input signal.

Each output data has its own dedicated output pin.

- Channel-status data (C, hereinafter) is output through COUT pin.
- User data (U, hereinafter) is output through UOUT pin.

The C and U outputs are synchronized with LRCKO recovered from the biphasic input signal.

The polarity of LRCKO recovered from the biphasic input signal depends on FMT[1:0] setting.

For detecting the top of the block of channel-status data or user data, the BFRAME pin is provided.

The BFRAME pin outputs a high level for an 8-LRCK period if the preamble *B* is detected in the received biphasic signal.

In processing these data by a microcontroller or register circuit, LRCKO is used as the data input clock, and the output pulse on the BFRAME pin is used as the top-of-block signal.

The relationship among LRCKO, BFRAME, DOUT, COUT, and UOUT is shown in [Figure 13](#).

When in the XTI mode and the PLL-locked state, COUT and UOUT output L.

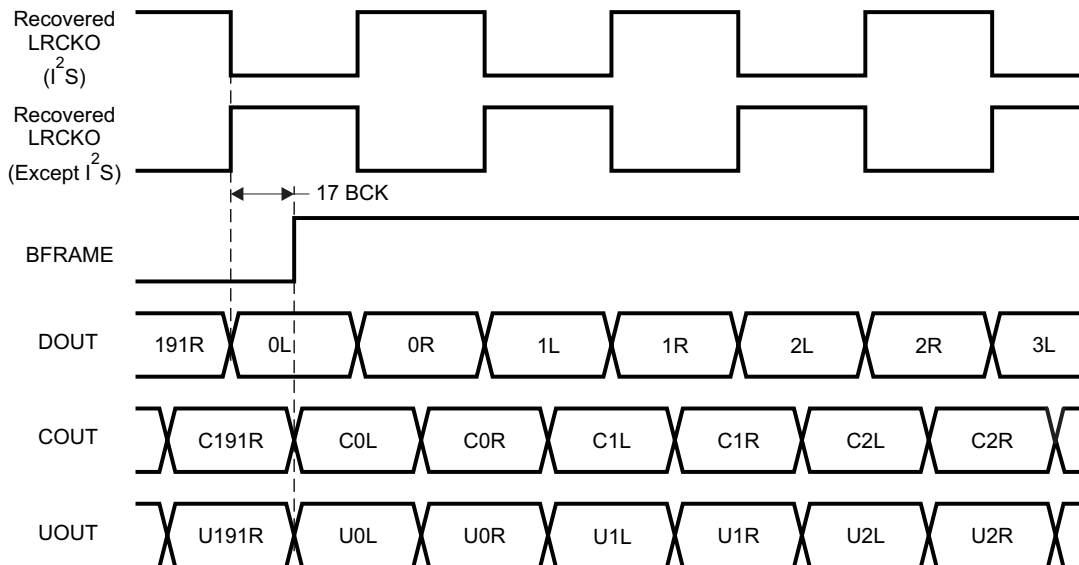

NOTE: The numbers 0 through 191 of DOUT, COUT, and UOUT indicate frame numbers of the biphasic input.

**Figure 13. LRCKO, DOUT, BFRAME, COUT, UOUT Output Timing**

## Channel-Status Data Information Output Terminal

The DIR9001 can output part of the channel-status information (bit 1, bit 3) through two dedicated pins,  $\overline{\text{AUDIO}}$  and EMPH.

The channel-status information which can be output from dedicated pins is limited to information from the L-channel.

If channel-status information other than AUDIO or EMPH is required, or information from the R-channel, then the channel-status data on the COUT pin, which is synchronized with biphasic input signal, can be used.

These outputs are synchronized with the top of block.

The information that can be output through the dedicated pins is shown as follows.

**AUDIO $\bar{O}$  Pin**

This is the output pin for the audio sample word information of the channel-status data bit 1.

**Table 8. Audio Sample Word Information**

AUDIO	DESCRIPTION
L	Audio sample word represents linear PCM samples.
H	Audio sample word is used for other purposes.

**EMPH Pin**

This is the output pin for the emphasis information of the channel-status data bit 3.

**Table 9. Pre-Emphasis Information**

EMPH	DESCRIPTION
L	Two audio channels without pre-emphasis
H	Two audio channels with 50 $\mu$ s / 15 $\mu$ s pre-emphasis

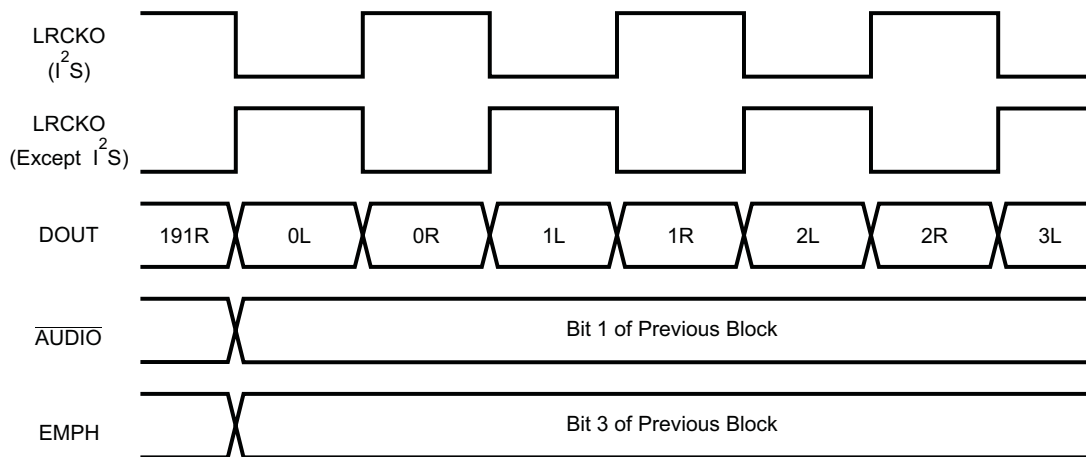

NOTE: The numbers 0 through 191 of DOUT indicate frame numbers of the biphase input.

**Figure 14. AUDIO $\bar{O}$  and EMPH Output Timing**

## ERRORS AND ERROR PROCESSING

### Error Output Description

Error detection and data error processing for PLL errors

- PLL responds with unlock for data in which the rule of biphase encoding is lost (biphase error and frame-length error).
- PLL responds with unlock for data in which the preamble B, M, W can not be detected.

Error processing function and error output pins

- The DIR9001 has a data error detect function and an error output pin, ERROR.
- The ERROR pin is defined as the logical OR of data error and parity error detection.
- The ERROR rising edge is synchronized with CLKST.
- The ERROR falling edge is synchronized with LRCK.

The relationship between data error and detected parity error is shown in [Figure 15](#).

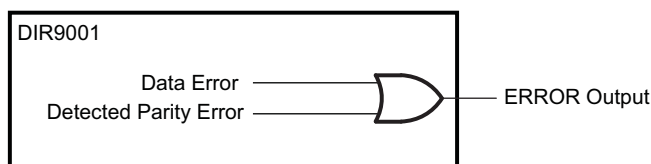

**Figure 15. ERROR Output**

The state of the ERROR pin and the details of error are shown in [Table 10](#).

**Table 10. State of ERROR Output Pin**

ERROR	DESCRIPTION
L	Lock state of PLL and nondetection of parity error
H	Unlock state of PLL or detection of parity error

### Parity Error Processing

Error detection and error processing for parity errors

- For PCM data, interpolation processing by previous data is performed.
- For non-PCM data, interpolation is not performed and data is directly output with no processing. (Non-PCM data is data with channel-status data bit 1 = 1.)

The processing for parity error occurrence is shown in [Figure 16](#).

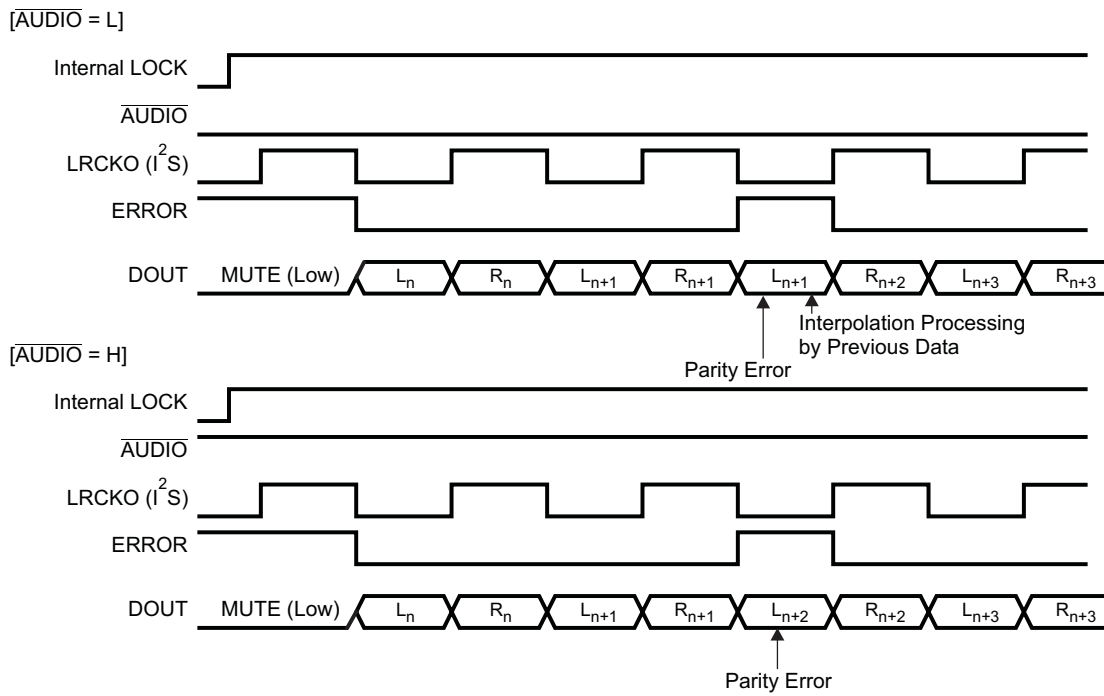

**Figure 16. Processing for Parity Error Occurrence**

**Other Error**

Error for sampling frequency change: A rapid continuous change or a discontinuous change of the input sampling frequency causes the PLL to lose lock.

## CALCULATION OF ACTUAL SAMPLING FREQUENCY

The DIR9001 calculates the actual sampling frequency of the biphasic input signal and outputs its result through dedicated pins.

To use this function, a 24.576-MHz clock source must be supplied to the XTI pin. The 24.576-MHz clock is used as a measurement reference clock to calculate the actual sampling frequency.

If the XTI pin is connected to DGND, calculation of the actual sampling frequency is not performed.

If there is an error in the XTI clock frequency, the calculation result and range are shifted correspondingly.

This output is the result of calculating the sampling frequency, it is not the sampling frequency information of the channel-status data (bit 24–bit 27).

The sampling frequency information of the channel-status data (bit 24–bit 27) is not output through these pins.

The calculation result is decoded into 2-bit data, which is output on the FSOUT[1:0] pins.

If the PLL is locked but the sampling frequency is out-of-range, or if the PLL is unlocked, FSOUT[1:0] = HL is output to indicate an abnormality.

When the XTI source clock is not supplied before power on, FSOUT [1:0] always outputs LL.

When the XTI source clock is stopped, the  $f_s$  calculator holds the last value of the  $f_s$  calculator result.

If XTI source clock is supplied, the  $f_s$  calculator resumes operation.

The calculated value is held until reset.

The relationship between the FSOUT[1:0] outputs and the range of sampling frequencies is shown in [Table 11](#).

**Table 11. Calculated Sampling Frequency Output**

NOMINAL $f_s$	ACTUAL SAMPLING FREQUENCY RANGE	CALCULATED SAMPLING FREQUENCY OUTPUT	
		FSOUT1	FSOUT0
Out of range	Out of range or PLL unlocked	H	L
32 kHz	31.2 kHz–32.8 kHz	H	H
44.1 kHz	43 kHz–45.2 kHz	L	L
48 kHz	46.8 kHz–49.2 kHz	L	H



**TYPICAL CIRCUIT CONNECTION**

Figure 17 illustrates typical circuit connection.

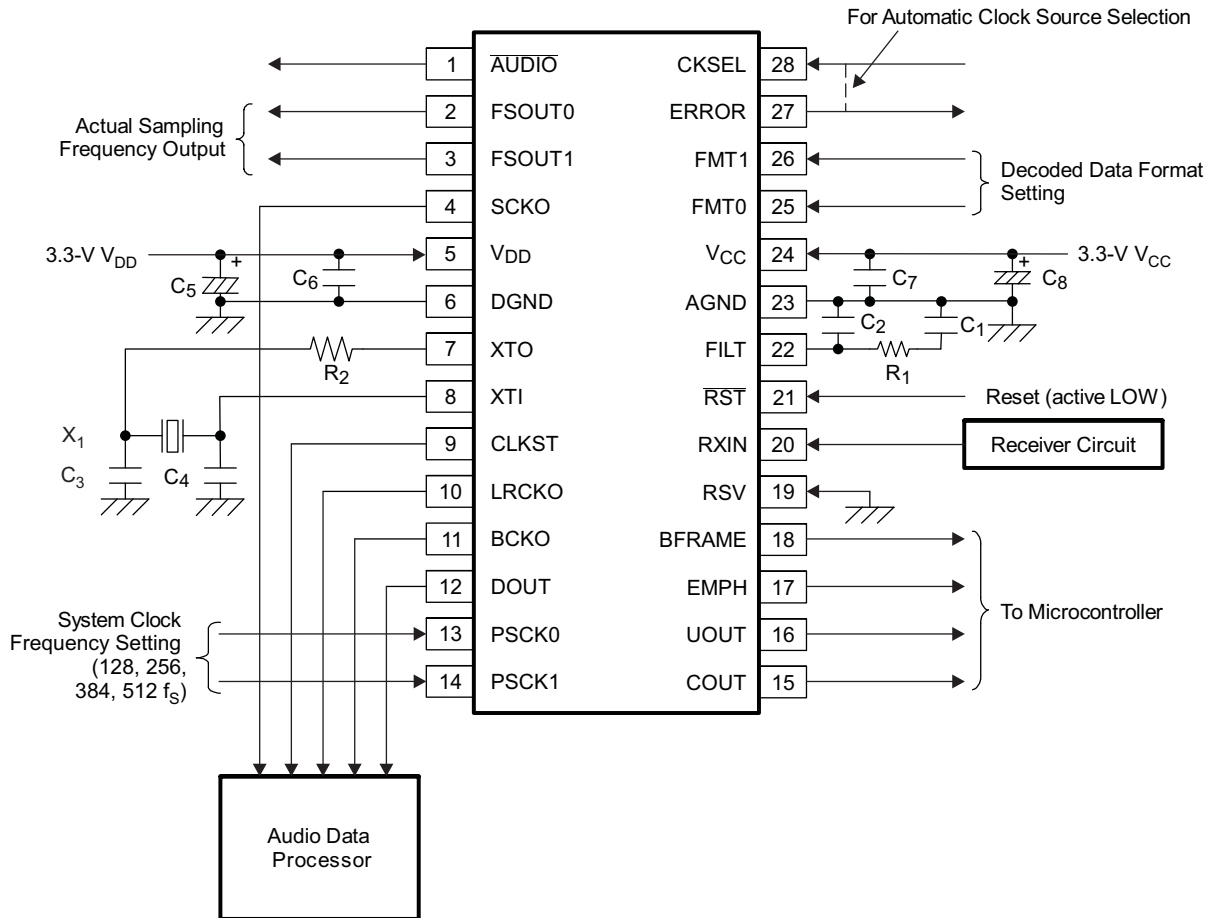

- NOTES: R<sub>1</sub>: Loop filter resistor, 680 Ω  
 R<sub>2</sub>: Current-limiting resistor; generally, a 100 Ω–500 Ω resistor is used, but it depends on the crystal resonator.  
 C<sub>1</sub>: Loop filter capacitor, 0.068 μF.  
 C<sub>2</sub>: Loop filter capacitor, 0.0047 μF.  
 C<sub>3</sub>, C<sub>4</sub>: OSC load capacitor; generally, a 10-pF–30-pF capacitor is used, but it depends on the crystal resonator and PCB layout.  
 C<sub>5</sub>, C<sub>8</sub>: 10-μF electrolytic capacitor typical, depending on power-supply quality and PCB layout.  
 C<sub>6</sub>, C<sub>7</sub>: 0.1-μF ceramic capacitor typical, depending on power-supply quality and PCB layout.  
 X<sub>1</sub>: Crystal resonator, use a 24.576-MHz fundamental resonator when XTI clock source is needed.

**Figure 17. Typical Circuit Connection Diagram**

## APPLICATION INFORMATION

### Differences for DIR1703

The DIR9001 has many improved functions compared to the DIR1703.

The DIR9001 functions are similar to those of the DIR1703.

The DIR9001 pin assignment is equivalent to that of the DIR1703.

The DIR9001 biphas input signal decoding function is almost equivalent to that of the DIR1703.

The differences between the DIR9001 and DIR1703 are shown in [Table 12](#).

**Table 12. Main Differences Between DIR1703 and DIR9001**

DIFFERENCE	DIR1703	DIR9001
Operational supply-voltage range	3 V to 3.6 V	2.7 V to 3.6 V
Operation temperature range	–25°C to 85°C	–40°C to 85°C
Package	SSOP-28P, pin pitch: 0.65 mm	TSSOP-28P, pin pitch: 0.65 mm
Clock recovery architecture	SpAct™ feature	Conventional PLL
IEC60958-3 jitter tolerance	Not compliant	Compliant
IEC60958 sampling frequency accuracy	Level II ( $\pm 1000$ ppm)	Level III ( $\pm 12.5\%$ )
Acceptable sampling frequency	32/44.1/48/88.2/96 kHz, $\pm 1500$ ppm	28 kHz to 108 kHz continuous
Biphase input signal level	CMOS level	5-V tolerant TTL level
Connection of loop filter	Between FILT pin and VCC	Between FILT pin and AGND
XTI source clock frequency	One of the following clock sources or resonators must be connected to the XTI pin: 4.069/5.6448/6.144/ 8.192/11.2896/12.288/ 16.384/16.9344/18.432/ 22.5792/24.576-MHz	Optional 24.576-MHz (24.576-MHz clock is only required to use the internal actual-sampling-frequency calculator or use the DIR9001 as a 24.576-MHz clock generator.)
BFRAME H period	$32/f_s$	$8/f_s$
Channel status and user data	Synchronous with LRCK transition	17-BCK delay from LRCK transition
Latest tracked frequency hold	Available	Not available
PLL mode clock at error	Latest tracked frequency	VCO free-running frequency
Clock transition signal out	CKTRNS pin, active H	CLKST pin, active-high
Oscillation amplifier	External feedback resistor (typ. 1 M $\Omega$ )	Internal feedback resistor

The differences between the DIR1703 and DIR9001 I/O pins are shown in [Table 13](#).

**Table 13. The Differences Between DIR1703 and DIR9001 in All I/O Pin**

PIN NO.	DIR1703	DIR9001	DIFFERENCES	DESCRIPTIONS OF DIR9001
1	ADFLG	$\overline{\text{AUDIO}}$	Pin name only	Channel-status data information of non-audio sample word, active-low
2	BRATE0	FSOUT0	Pin name only	Actual-sampling-frequency calculated result output 0
3	BRATE1	FSOUT1	Pin name only	Actual-sampling-frequency calculated result output 1
4	SCKO	SCKO	Same function	System clock output
5	V <sub>DD</sub>	V <sub>DD</sub>	Same function	Digital power supply, 3.3-V
6	DGND	DGND	Same function	Digital ground
7	XTO	XTO	Same function	Oscillation amplifier output
8	XTI	XTI	Same function	Oscillation amplifier input, or external XTI source clock input
9	CKTRNS	CLKST	CLKST is active-high	Clock change/transition signal output
10	LRCKO	LRCKO	Same function	Audio data latch enable output
11	BCKO	BCKO	Same function	Audio data bit clock output
12	DOUT	DOUT	Same function	16 bit–24 bit decoded serial digital audio data output
13	SCF0	PSCK0	Pin name only	SCKO output frequency selection 0
14	SCF1	PSCK1	Pin name only	SCKO output frequency selection 1
15	CSBIT	COUT	Pin name only	Channel-status data serial output synchronized with LRCKO
16	URBIT	UOUT	Pin name only	User data serial output synchronized with LRCKO
17	EMFLG	EMPH	Pin name only	Channel-status data Information of pre-emphasis (50 $\mu$ s/15 $\mu$ s)
18	BFRAME	BFRAME	Same function	Indication of top block of biphase input signal
19	BRSEL	RSV	Reserved	Reserved, must be connected to DGND
20	DIN	RXIN	Pin name only	Biphase digital data input
21	$\overline{\text{RST}}$	$\overline{\text{RST}}$	Same function	Reset control input, active-low
22	FILT	FILT	Same function	External filter connection terminal. Recommended filter must be connected.
23	AGND	AGND	Same function	Analog ground
24	V <sub>CC</sub>	V <sub>CC</sub>	Same function	Analog power supply, 3.3-V
25	FMT0	FMT0	Same function	Decoded serial digital audio data output format selection 0
26	FMT1	FMT1	Same function	Decoded serial digital audio data output format selection 1
27	UNLOCK	ERROR	Pin name only	Indication of internal PLL or data parity error
28	CKSEL	CKSEL	Same function	Selection of system clock source, Low: PLL (VCO) clock, High: XTI clock

**PACKAGING INFORMATION**

Orderable Device	Status <sup>(1)</sup>	Package Type	Package Drawing	Pins	Package Qty	Eco Plan <sup>(2)</sup>	Lead/Ball Finish	MSL Peak Temp <sup>(3)</sup>
DIR9001PW	ACTIVE	TSSOP	PW	28	50	Green (RoHS & no Sb/Br)	CU NIPDAU	Level-1-260C-UNLIM
DIR9001PWG4	ACTIVE	TSSOP	PW	28	50	Green (RoHS & no Sb/Br)	CU NIPDAU	Level-1-260C-UNLIM
DIR9001PWR	ACTIVE	TSSOP	PW	28	2000	Green (RoHS & no Sb/Br)	CU NIPDAU	Level-1-260C-UNLIM
DIR9001PWRG4	ACTIVE	TSSOP	PW	28	2000	Green (RoHS & no Sb/Br)	CU NIPDAU	Level-1-260C-UNLIM

<sup>(1)</sup> The marketing status values are defined as follows:

**ACTIVE:** Product device recommended for new designs.

**LIFEBUY:** TI has announced that the device will be discontinued, and a lifetime-buy period is in effect.

**NRND:** Not recommended for new designs. Device is in production to support existing customers, but TI does not recommend using this part in a new design.

**PREVIEW:** Device has been announced but is not in production. Samples may or may not be available.

**OBSOLETE:** TI has discontinued the production of the device.

<sup>(2)</sup> Eco Plan - The planned eco-friendly classification: Pb-Free (RoHS), Pb-Free (RoHS Exempt), or Green (RoHS & no Sb/Br) - please check <http://www.ti.com/productcontent> for the latest availability information and additional product content details.

**TBD:** The Pb-Free/Green conversion plan has not been defined.

**Pb-Free (RoHS):** TI's terms "Lead-Free" or "Pb-Free" mean semiconductor products that are compatible with the current RoHS requirements for all 6 substances, including the requirement that lead not exceed 0.1% by weight in homogeneous materials. Where designed to be soldered at high temperatures, TI Pb-Free products are suitable for use in specified lead-free processes.

**Pb-Free (RoHS Exempt):** This component has a RoHS exemption for either 1) lead-based flip-chip solder bumps used between the die and package, or 2) lead-based die adhesive used between the die and leadframe. The component is otherwise considered Pb-Free (RoHS compatible) as defined above.

**Green (RoHS & no Sb/Br):** TI defines "Green" to mean Pb-Free (RoHS compatible), and free of Bromine (Br) and Antimony (Sb) based flame retardants (Br or Sb do not exceed 0.1% by weight in homogeneous material)

<sup>(3)</sup> MSL, Peak Temp. -- The Moisture Sensitivity Level rating according to the JEDEC industry standard classifications, and peak solder temperature.

**Important Information and Disclaimer:**The information provided on this page represents TI's knowledge and belief as of the date that it is provided. TI bases its knowledge and belief on information provided by third parties, and makes no representation or warranty as to the accuracy of such information. Efforts are underway to better integrate information from third parties. TI has taken and continues to take reasonable steps to provide representative and accurate information but may not have conducted destructive testing or chemical analysis on incoming materials and chemicals. TI and TI suppliers consider certain information to be proprietary, and thus CAS numbers and other limited information may not be available for release.

In no event shall TI's liability arising out of such information exceed the total purchase price of the TI part(s) at issue in this document sold by TI to Customer on an annual basis.

**OTHER QUALIFIED VERSIONS OF DIR9001 :**

- Automotive: [DIR9001-Q1](#)

NOTE: Qualified Version Definitions:

- Automotive - Q100 devices qualified for high-reliability automotive applications targeting zero defects

**TAPE AND REEL INFORMATION**
**REEL DIMENSIONS**

**TAPE DIMENSIONS**

A0	Dimension designed to accommodate the component width
B0	Dimension designed to accommodate the component length
K0	Dimension designed to accommodate the component thickness
W	Overall width of the carrier tape
P1	Pitch between successive cavity centers

**TAPE AND REEL INFORMATION**

\*All dimensions are nominal

Device	Package Type	Package Drawing	Pins	SPQ	Reel Diameter (mm)	Reel Width W1 (mm)	A0 (mm)	B0 (mm)	K0 (mm)	P1 (mm)	W (mm)	Pin1 Quadrant
DIR9001PWR	TSSOP	PW	28	2000	330.0	16.4	6.9	10.2	1.8	12.0	16.0	Q1

**TAPE AND REEL BOX DIMENSIONS**



\*All dimensions are nominal

Device	Package Type	Package Drawing	Pins	SPQ	Length (mm)	Width (mm)	Height (mm)
DIR9001PWR	TSSOP	PW	28	2000	367.0	367.0	38.0

# MECHANICAL DATA

PW (R-PDSO-G28)

PLASTIC SMALL OUTLINE



4040064-7/G 02/11

- NOTES:
- A. All linear dimensions are in millimeters. Dimensioning and tolerancing per ASME Y14.5M-1994.
  - B. This drawing is subject to change without notice.
  - C. Body length does not include mold flash, protrusions, or gate burrs. Mold flash, protrusions, or gate burrs shall not exceed 0,15 each side.
  - D. Body width does not include interlead flash. Interlead flash shall not exceed 0,25 each side.
  - E. Falls within JEDEC MO-153

PW (R-PDSO-G28)

PLASTIC SMALL OUTLINE

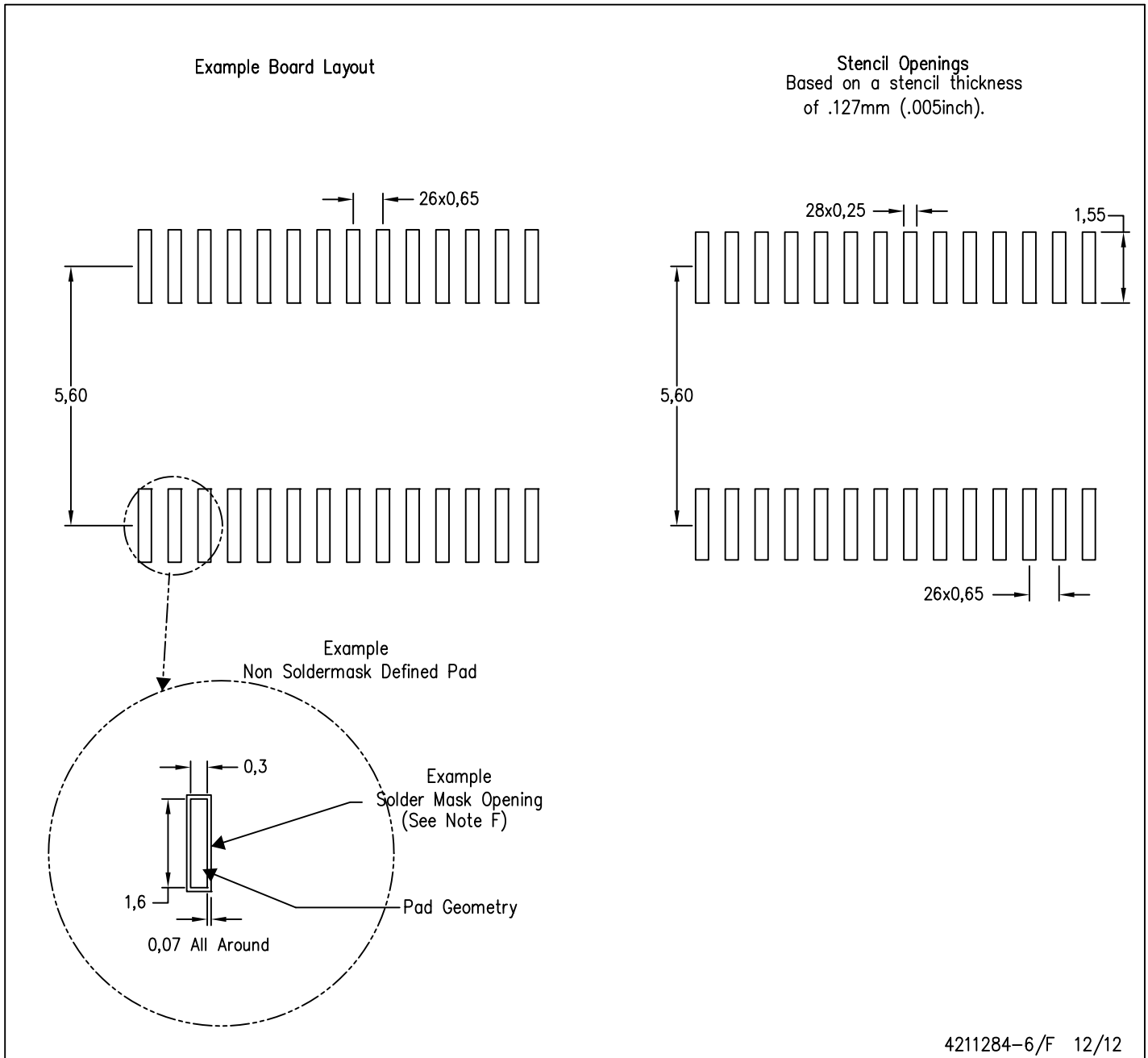

- NOTES:
- A. All linear dimensions are in millimeters.
  - B. This drawing is subject to change without notice.
  - C. Publication IPC-7351 is recommended for alternate design.
  - D. Laser cutting apertures with trapezoidal walls and also rounding corners will offer better paste release. Customers should contact their board assembly site for stencil design recommendations. Refer to IPC-7525 for other stencil recommendations.
  - E. Customers should contact their board fabrication site for solder mask tolerances between and around signal pads.



PW (R-PDSO-G28)

PLASTIC SMALL OUTLINE

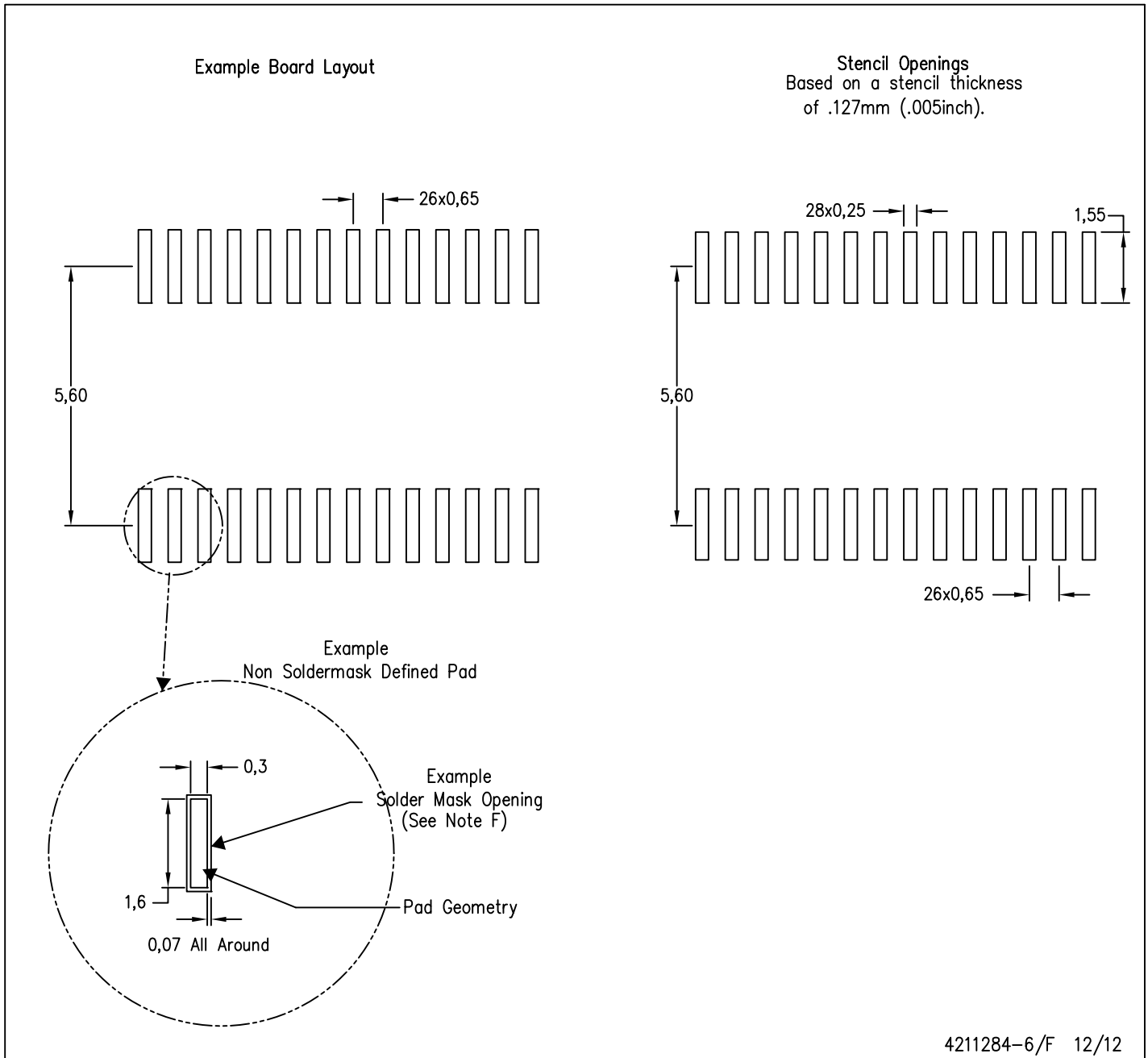

- NOTES:
- A. All linear dimensions are in millimeters.
  - B. This drawing is subject to change without notice.
  - C. Publication IPC-7351 is recommended for alternate design.
  - D. Laser cutting apertures with trapezoidal walls and also rounding corners will offer better paste release. Customers should contact their board assembly site for stencil design recommendations. Refer to IPC-7525 for other stencil recommendations.
  - E. Customers should contact their board fabrication site for solder mask tolerances between and around signal pads.

## IMPORTANT NOTICE

Texas Instruments Incorporated and its subsidiaries (TI) reserve the right to make corrections, enhancements, improvements and other changes to its semiconductor products and services per JESD46, latest issue, and to discontinue any product or service per JESD48, latest issue. Buyers should obtain the latest relevant information before placing orders and should verify that such information is current and complete. All semiconductor products (also referred to herein as "components") are sold subject to TI's terms and conditions of sale supplied at the time of order acknowledgment.

TI warrants performance of its components to the specifications applicable at the time of sale, in accordance with the warranty in TI's terms and conditions of sale of semiconductor products. Testing and other quality control techniques are used to the extent TI deems necessary to support this warranty. Except where mandated by applicable law, testing of all parameters of each component is not necessarily performed.

TI assumes no liability for applications assistance or the design of Buyers' products. Buyers are responsible for their products and applications using TI components. To minimize the risks associated with Buyers' products and applications, Buyers should provide adequate design and operating safeguards.

TI does not warrant or represent that any license, either express or implied, is granted under any patent right, copyright, mask work right, or other intellectual property right relating to any combination, machine, or process in which TI components or services are used. Information published by TI regarding third-party products or services does not constitute a license to use such products or services or a warranty or endorsement thereof. Use of such information may require a license from a third party under the patents or other intellectual property of the third party, or a license from TI under the patents or other intellectual property of TI.

Reproduction of significant portions of TI information in TI data books or data sheets is permissible only if reproduction is without alteration and is accompanied by all associated warranties, conditions, limitations, and notices. TI is not responsible or liable for such altered documentation. Information of third parties may be subject to additional restrictions.

Resale of TI components or services with statements different from or beyond the parameters stated by TI for that component or service voids all express and any implied warranties for the associated TI component or service and is an unfair and deceptive business practice. TI is not responsible or liable for any such statements.

Buyer acknowledges and agrees that it is solely responsible for compliance with all legal, regulatory and safety-related requirements concerning its products, and any use of TI components in its applications, notwithstanding any applications-related information or support that may be provided by TI. Buyer represents and agrees that it has all the necessary expertise to create and implement safeguards which anticipate dangerous consequences of failures, monitor failures and their consequences, lessen the likelihood of failures that might cause harm and take appropriate remedial actions. Buyer will fully indemnify TI and its representatives against any damages arising out of the use of any TI components in safety-critical applications.

In some cases, TI components may be promoted specifically to facilitate safety-related applications. With such components, TI's goal is to help enable customers to design and create their own end-product solutions that meet applicable functional safety standards and requirements. Nonetheless, such components are subject to these terms.

No TI components are authorized for use in FDA Class III (or similar life-critical medical equipment) unless authorized officers of the parties have executed a special agreement specifically governing such use.

Only those TI components which TI has specifically designated as military grade or "enhanced plastic" are designed and intended for use in military/aerospace applications or environments. Buyer acknowledges and agrees that any military or aerospace use of TI components which have **not** been so designated is solely at the Buyer's risk, and that Buyer is solely responsible for compliance with all legal and regulatory requirements in connection with such use.

TI has specifically designated certain components as meeting ISO/TS16949 requirements, mainly for automotive use. In any case of use of non-designated products, TI will not be responsible for any failure to meet ISO/TS16949.

### Products

Audio	<a href="http://www.ti.com/audio">www.ti.com/audio</a>
Amplifiers	<a href="http://amplifier.ti.com">amplifier.ti.com</a>
Data Converters	<a href="http://dataconverter.ti.com">dataconverter.ti.com</a>
DLP® Products	<a href="http://www.dlp.com">www.dlp.com</a>
DSP	<a href="http://dsp.ti.com">dsp.ti.com</a>
Clocks and Timers	<a href="http://www.ti.com/clocks">www.ti.com/clocks</a>
Interface	<a href="http://interface.ti.com">interface.ti.com</a>
Logic	<a href="http://logic.ti.com">logic.ti.com</a>
Power Mgmt	<a href="http://power.ti.com">power.ti.com</a>
Microcontrollers	<a href="http://microcontroller.ti.com">microcontroller.ti.com</a>
RFID	<a href="http://www.ti-rfid.com">www.ti-rfid.com</a>
OMAP Applications Processors	<a href="http://www.ti.com/omap">www.ti.com/omap</a>
Wireless Connectivity	<a href="http://www.ti.com/wirelessconnectivity">www.ti.com/wirelessconnectivity</a>

### Applications

Automotive and Transportation	<a href="http://www.ti.com/automotive">www.ti.com/automotive</a>
Communications and Telecom	<a href="http://www.ti.com/communications">www.ti.com/communications</a>
Computers and Peripherals	<a href="http://www.ti.com/computers">www.ti.com/computers</a>
Consumer Electronics	<a href="http://www.ti.com/consumer-apps">www.ti.com/consumer-apps</a>
Energy and Lighting	<a href="http://www.ti.com/energy">www.ti.com/energy</a>
Industrial	<a href="http://www.ti.com/industrial">www.ti.com/industrial</a>
Medical	<a href="http://www.ti.com/medical">www.ti.com/medical</a>
Security	<a href="http://www.ti.com/security">www.ti.com/security</a>
Space, Avionics and Defense	<a href="http://www.ti.com/space-avionics-defense">www.ti.com/space-avionics-defense</a>
Video and Imaging	<a href="http://www.ti.com/video">www.ti.com/video</a>

### TI E2E Community

[e2e.ti.com](http://e2e.ti.com)