

**SANYO**

No. 4021

**LC73720****Dialer With Memory****OVERVIEW**

The LC73720 is a DTMF/output pulse dial CMOS LSI for pushbutton telephones. It contains 16-digit 24-telephone number one-touch autodialing memory, 21-telephone number abbreviated dialing memory (common with one-touch dialing), and 63-digit redialing memory, as well as on-hook dialing, and privacy functions on a single chip.

**FEATURES**

- Uses CMOS processes that can work directly with telephone lines.
- Single-contact keyboards can be used.
- The built-in oscillator ( $f_{osc}=3.58$  MHz) can use color television crystal oscillators and ceramic resonators.
- The use of a high-precision DTMF signal frequency generation circuit ( $\pm 0.1\%$ ) makes it easy to distinguish ceramic resonators.
- 16-digit 24-telephone number one-touch autodialing memory and 21-telephone number abbreviated dialing memory (common with one-touch dialing) are built in.
- Memory registration can specify on-hook or off-hook.
- Mode changes, pauses, and hooking data can be written into dialing memory.
- This chip is equipped with a 63-digit redialing memory.
- For mode switching, a pause (2.0 seconds) is inserted automatically.
- After the flash operation, a pause (1.0 second) is inserted automatically.
- Mode changes are one direction, from pulse mode to tone mode.
- Each time there is valid key input, a 1036Hz, 31ms key (except for DTMF keys) sound is output.
- When memory registration is complete, a sound verifying the completion of registration is output (2072 Hz, 279 ms for each telephone number).
- When a memory with nothing registered in it is accessed, a warning sound (2072 Hz, 31 ms, 5 times) is output.
- DTMF mode generates 12 types of signals.
- This chip has on-hook dialing mode.
- Keyboard data serial input is possible.
- This chip has Busy-Out (showing dialing output underway).
- This chip has privacy mode.
- The dial pulse rate can be set to either 10 pps or 20 pps.
- The dial pulse make ratio can be set to 33% or 39%.
- Wide operating power voltage
 

Pulse mode	: $V_{DD} = 1.5$ to $5.5$ V
DTMF mode	: $V_{DD} = 2.0$ to $5.5$ V
- Low current consumption operation
 

Pulse mode	: $I_{DD} = 0.5$ mA max. ( $V_{DD} = 3.0$ V)
DTMF mode	: $I_{DD} = 1.0$ mA max. ( $V_{DD} = 3.0$ V)
- Low standby current
 

	: $I_{dr} = 0.5$ $\mu$ A max. ( $V_{DD} = 1.0$ V)
--	---
- Dual inline 36-pin shrink package

# LC73720

## Pinout

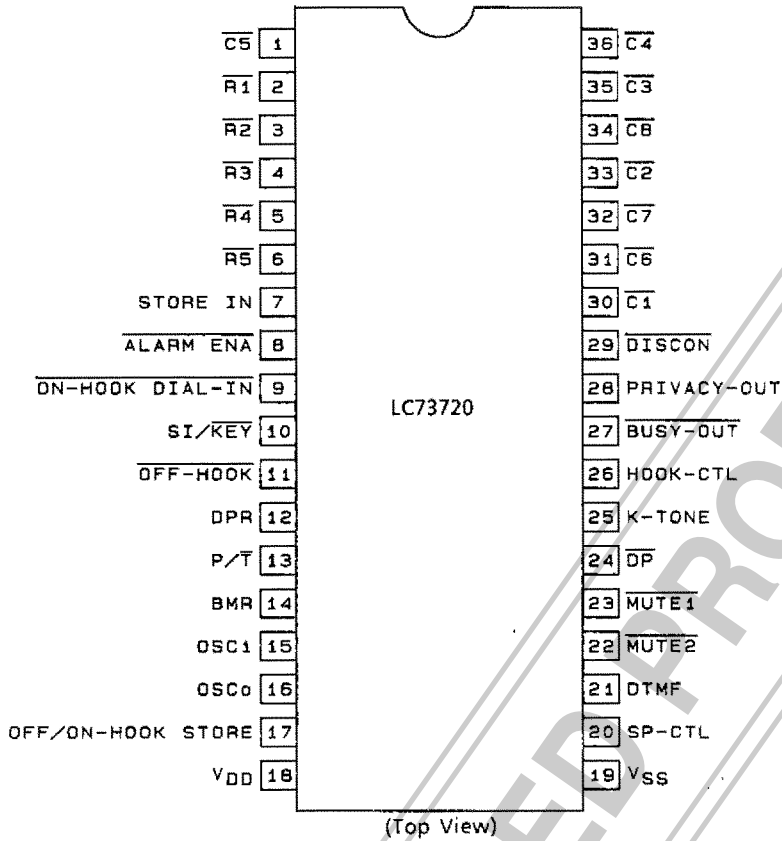

A00479

**Package Dimensions**  
unit:mm  
3170-DIP36S

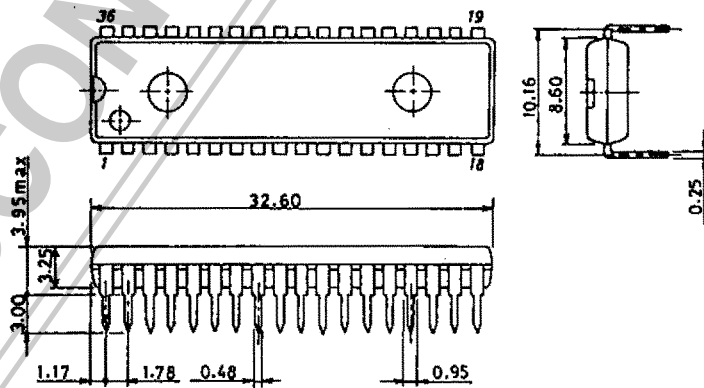

Block Diagram

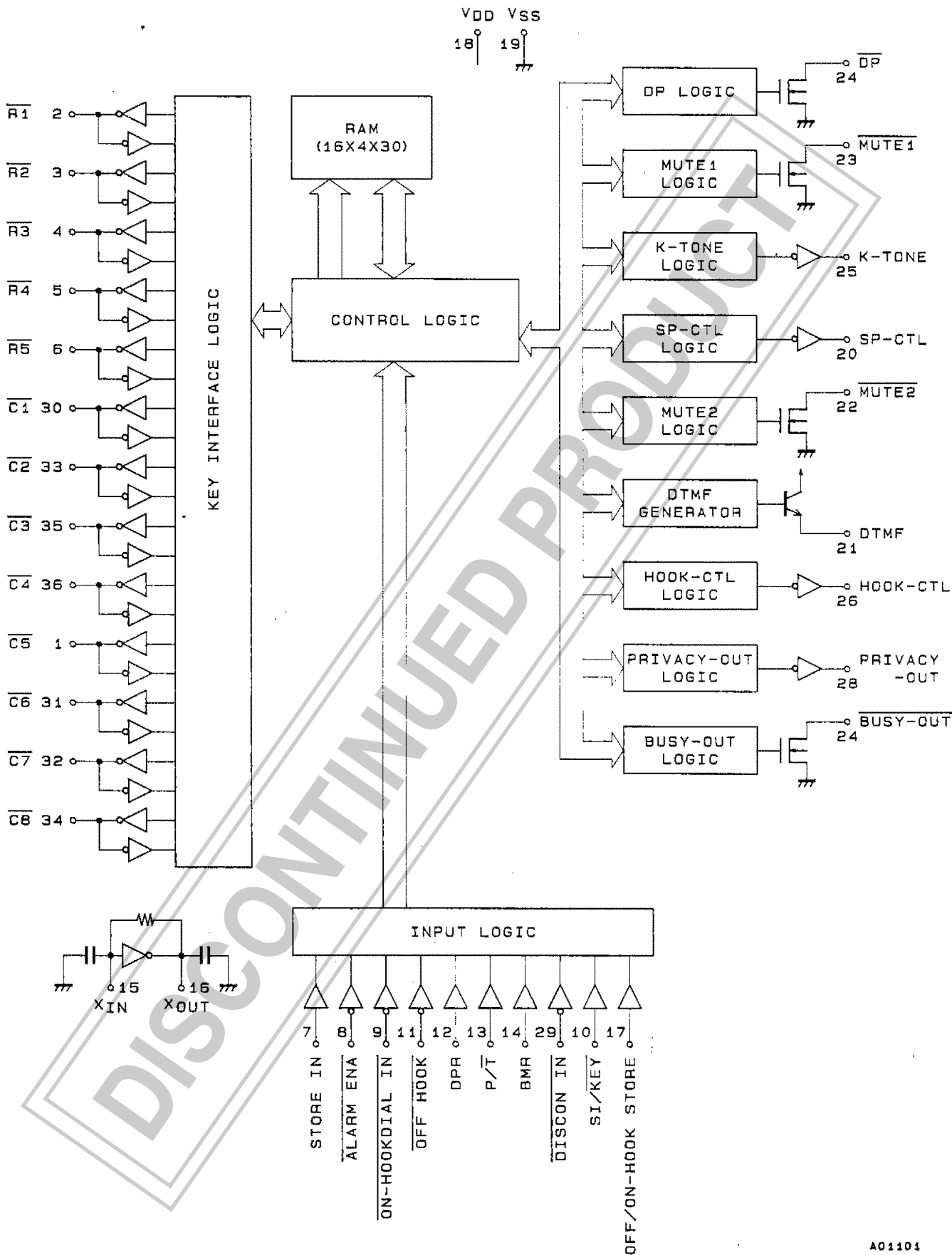

A01101

## Pin Description

Pin No.	Pin Name	Function	
1	$\overline{C5}$	COLUMN input	
2	$\overline{R1}$	] ROW input	
3	$\overline{R2}$		
4	$\overline{R3}$		
5	$\overline{R4}$		
6	$\overline{R5}$		
7	STORE IN	Memory registration mode input	H = registration mode
8	$\overline{ALARMENA}$	Alarm switch	Falling edge detectionHook switch input
9	$\overline{ON-HOOKDIAL-IN}$	ON-HOOK-DIAL input	Falling edge detectionDial pulse rate switch
10	$\overline{SI/KEY}$	Serial input/keyboard input switch	Rising edge detectionPulse/tone switch
11	$\overline{OFF-HOOK}$	Hook switch input	
12	DPR	Dial pulse rate switch	H=20pps, L=10pps
13	$\overline{P/T}$	Pulse/tone switch	H=pulse, L=tone
14	BMR	Make ratio switch input	H=33%, L=39%
15	X IN	] Oscillation circuit	Crystal oscillator connected, 3.58 MHz When using a ceramic resonator, a capacitor of approximately 30pF must be connected to each pin.
16	X OUT		
17	$\overline{OFF/ON-HOOK STORE}$	$\overline{OFF-HOOK STORE/ON-HOOK STORE}$ switch	
18	$V_{DD}$	] Power pins	
19	$V_{SS}$		
20	SP-CTL	Speaker receive control output	Complementary output
21	DTMF	DTMF output	NPN emitter follower output
22	$\overline{MUTE2}$	DTMF mute output	Nch open drain output
23	$\overline{MUTE1}$	DP mute output	Nch open drain output
24	$\overline{DP}$	Dial pulse output	Nch open drain output
25	K-TONE	K-TONE output	Complementary output
26	$\overline{HOOK-CTL}$	HOOK control output	Complementary output
27	$\overline{BUSY-OUT}$	BUSY output	
28	$\overline{PRIVACY-OUT}$	PRIVACY output	
29	$\overline{DISCON}$	Disconnect input	
30	$\overline{C1}$	] COLUMN input	
31	$\overline{C6}$		
32	$\overline{C7}$		
33	$\overline{C2}$		
34	$\overline{C8}$		
35	$\overline{C3}$		
36	$\overline{C4}$		

## Keyboard Assignment

$\overline{R1}$	1	2	3	HK	M16	M11	M06	M01
	4	5	6	M	M17	M12	M07	M02
	7	8	9	R/P	M18	M13	M08	M03
$\overline{R5}$	*	0	#	PRIV ON/OFF	M19	M14	M09	M04
	A1	A2	A3	M00	M20	M15	M10	M05
	$\overline{C1}$			~				$\overline{C8}$

LC73720

**Absolute Maximum ratings/ Ta=25°C**

			Unit
Maximum Supply Voltage	V <sub>DD</sub> max	-0.3 to +6.5	V
Maximum Input Voltage	V <sub>IN</sub> max	-0.3 to V <sub>DD</sub> +0.3	V
Maximum Output Voltage	V <sub>OUT</sub> max	-0.3 to V <sub>DD</sub> +0.3	V
Allowable power Dissipation	Pd max	Ta≤70°C 250	mW
Minimum Load Resistance	R <sub>L</sub> min	DTMF to V <sub>ss</sub> pin 1	kΩ
Operation Ambient Temperature	T <sub>opr</sub>	-30 to +70	°C
Storage Ambient Temperature	T <sub>sig</sub>	-40 to +125	°C

**Allowable Operating Ranges/ Ta=25°C**

	min	typ	max	unit	
Power Supply Voltage	V <sub>DDP</sub>	Pulse mode 1.5	5.5	V	
	V <sub>DDT</sub>	DTMF mode 2.0	5.5	V	
Input [ H ] level voltage	V <sub>IH</sub>	All input pins 0.7V <sub>DD</sub>	V <sub>DD</sub>	V	
Input [ L ] level voltage	V <sub>IL</sub>	All input pins V <sub>SS</sub>	0.3V <sub>DD</sub>	V	
Key Contact Resistance	R <sub>KI</sub>		3.0	kΩ	
Keyboard Capacitance	C <sub>KI</sub>		330	pF	
Resonator Specification	f	Center frequency = 3.579545 MHz	-1.3	+1.3	%
	R <sub>S</sub>		100	Ω	

**Electrical Characteristics/ Ta=25°C, fosc=3.579545 MHz**

		min	typ	max	unit
Operation consumption current	I <sub>DDP</sub>	Dial pulse output, output open, V <sub>DD</sub> =3.0 V	0.3	0.5	mA
	I <sub>DDT</sub>	DTMF output, output open, V <sub>DD</sub> =3.0 V	0.5	1.0	mA
Quiescent Current	I <sub>DD(ST)</sub>	Standby mode, output open, V <sub>DD</sub> =1.5 to 5.5 V		1	μA
Memory Retention Voltage	V <sub>DR</sub>		1		V
Memory Retention Current	I <sub>DR</sub>	V <sub>DD</sub> =1V		0.5	μA
Input Pin Current	I <sub>IH1</sub>	STORE IN, ALARM ENA, ON-HOOK DIAL-IN, SI/KEY, OFF-HOOK, DPR, P/T, BMR, OFF/ON- HOOK STORE, DISCON pin: V <sub>IH</sub> =V <sub>DD</sub>		1	μA
	I <sub>IL1</sub>	STORE IN, ALARM ENA, ON-HOOK DIAL-IN, SI/KEY, OFF-HOOK, DPR, P/T, BMR, OFF/ON-HOOK STORE, DISCON pin: V <sub>IL</sub> =V <sub>DD</sub>	-1		μA
Key Pin Current	I <sub>ILK1</sub>	All key pins: V <sub>DD</sub> =1.5V, V <sub>ILK</sub> =V <sub>SS</sub>	-20		μA
	I <sub>ILK2</sub>	All key pins: V <sub>DD</sub> =5.5V, V <sub>ILK</sub> =V <sub>SS</sub>	-300		μA
	I <sub>OLK1</sub>	All key pins: V <sub>DD</sub> =1.5V, V <sub>OLK</sub> =0.4 V	200		μA
	I <sub>OLK2</sub>	All key pins: V <sub>DD</sub> =5.5V, V <sub>OLK</sub> =0.4 V	0.7		mA
Output Pin Leak Current	I <sub>OFF</sub>	V <sub>O</sub> =V <sub>DD</sub> , V <sub>DD</sub> =5.5 V, output off DP, MUTE1, MUTE2, BUSY-OUT pin		1	μA
Output Pin Voltage	V <sub>OH1</sub>	K-TONE, HOOK-CTL, SP-CTL, PRIVACY-OUT pin: V <sub>DD</sub> =1.5 V, I <sub>OH</sub> =-250μA	V <sub>DD</sub> -0.5		V
	V <sub>OH2</sub>	K-TONE, HOOK-CTL, SP-CTL, PRIVACY-OUT pin: V <sub>DD</sub> =5.5 V, I <sub>OH</sub> =-1 mA	V <sub>DD</sub> -1		V
	V <sub>OL1</sub>	K-TONE, DP, MUTE1, MUTE2, SP-CTL, HOOK-CTL, BUSY-OUT, PRIVACY-OUT pin: V <sub>DD</sub> =1.5V, I <sub>OL</sub> =250 μA		0.4	V
	V <sub>OL2</sub>	K-TONE, DP, MUTE1, MUTE2, SP-CTL, HOOK-CTL, BUSY-OUT, PRIVACY-OUT pin: V <sub>DD</sub> =5.5V, I <sub>OL</sub> =1 mA		0.4	V

LC73720

AC Characteristics/ Ta=25°C, fosc=3.579545 MHz

			min	typ	max	unit
Key Debounce time	T <sub>KD</sub>		16.4	17.5	18.4	ms
Pin Chattering Rejection Time	T <sub>PCHT</sub>		28.9	30	30.9	ms
Key Scan Frequency	f <sub>KSC</sub>			258.9		Hz
Key Tone Frequency	f <sub>KT</sub>			1035.7		Hz
Key Tone Output Time	T <sub>KT</sub>			30.9		ms
Auto Pause Time	T <sub>AP</sub>	At 10pps pulse mode	1.98	2.0	2.03	sec
		At 20pps pulse mode	1.98	2.0	2.03	sec
		DTMF mode	1.98	2.0	2.03	sec
DTMF Output Time	T <sub>MFOFON</sub>		79	81	83	ms
DTMF Interdigit pause Time	T <sub>MFOFF</sub>		70	72	74	ms
Hooking Time	T <sub>HK</sub>		700	710	720	ms
Hooking Pause Time	T <sub>HKP</sub>		710	720	730	s
Memory Store Confirmed Frequency	f <sub>KST</sub>			2071.4		Hz
Memory Store Confirmed Time	T <sub>KSTON</sub>			278.1		ms
Alarm Frequency	f <sub>KALM</sub>			2071.4		Hz
Low Tone Amplitude	V <sub>OR</sub>	V <sub>DD</sub> =3.5V, R <sub>L</sub> =10kΩ	165	200	240	mVrms
Tone Output Ratio	dBCR	V <sub>DD</sub> =2.0 to 5.5, R <sub>L</sub> =10kΩ	1	2	3	dB
Tone Output Distortion	%DIS	V <sub>DD</sub> =2.0 to 5.5V, R <sub>L</sub> =10kΩ			10	%
Oscillation Start Time	T <sub>START</sub>	V <sub>DD</sub> =1.5 to 5.5V			30	ms
		V <sub>DD</sub> =3.0V		1		ms

Dial Pulse Output/fosc = 3.579545 MHz

DPR Pin BMR Pin Dial pulse rate Interdigit pause Make ratio

DTMF output/fosc = 3.579545 MHz

Input Output frequency [Hz] Standard Deviation [%]

State Diagram

STORE = ON

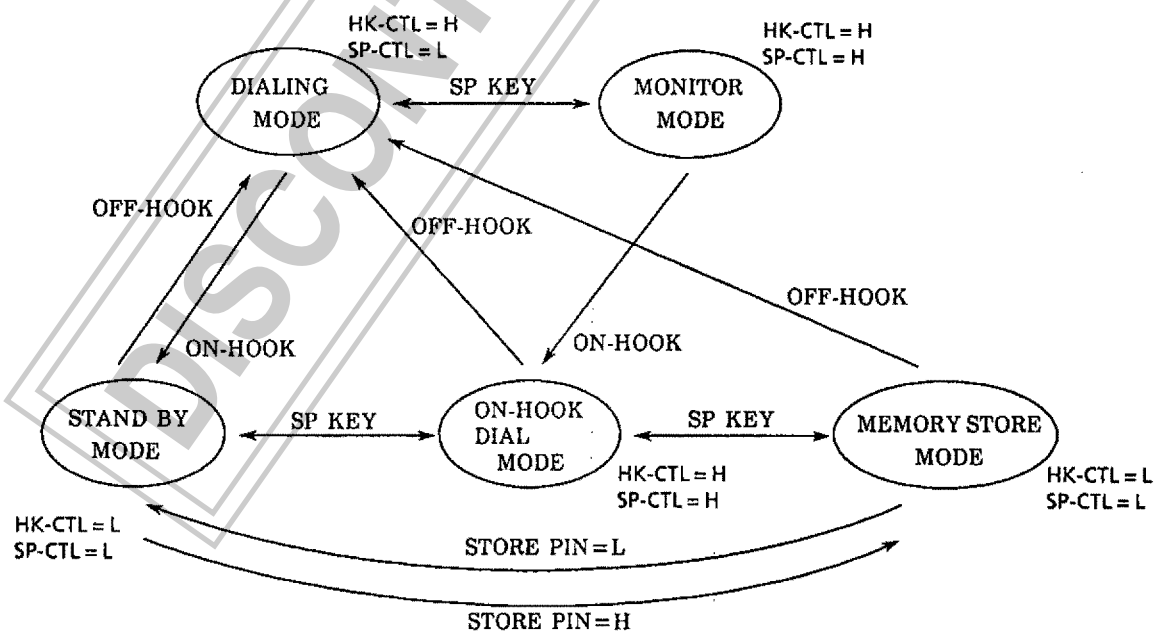

State Diagram

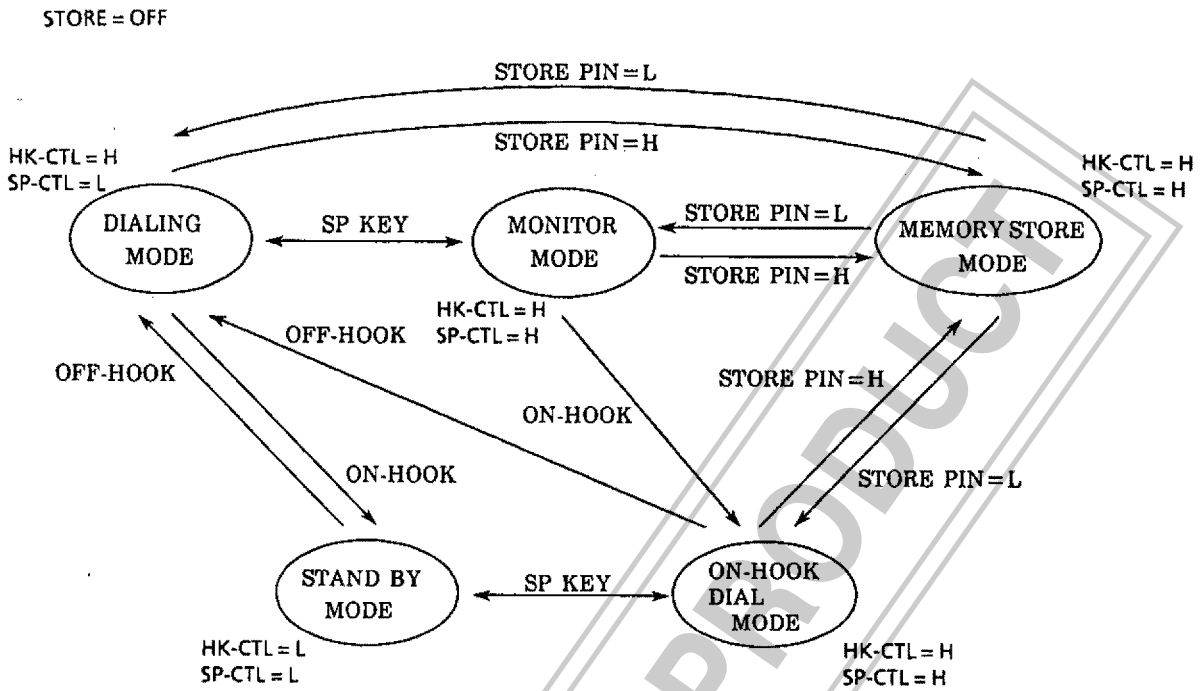

Dial Pulse Output/fosc = 3.579545 MHz

DPR Pin	BMR Pin	Dial pulse rate	Interdigit pause	Make ratio
V <sub>SS</sub>	V <sub>DD</sub>	9.94 pps	834.2ms	33.2%
V <sub>DD</sub>	V <sub>DD</sub>	19.89 pps	525.2ms	33.2%
V <sub>SS</sub>	V <sub>SS</sub>	9.94 pps	834.2ms	39.2%
V <sub>DD</sub>	V <sub>SS</sub>	19.89 pps	525.2ms	39.2%

DTMF output/fosc = 3.579545 MHz

Input	Output frequency [Hz]		Deviation [%]
	Standard	LC73720	
R1	697	697.0	+0.01
R2	770	770.1	-0.02
R3	852	852.3	-0.03
R4	941	942.0	-0.11
C1	1209	1209.3	-0.03
C2	1336	1335.7	+0.03
C3	1477	1476.7	+0.02

**LC73720 function specifications**

The LC73720 can use pulse dialing, DTMF dialing, and bidirectional mixed dialing and can use one-touch dialing, abbreviated dialing, and redialing with those types of dialing.

**(1) Dial output function**

- The pulse mode output mode make ratio can be set to 33% or 39% with the BMR pin.
- The pulse mode output mode rate can be set to 20 PPS or 10 pps with the DPR pin.
- The DTMF mode generates 12 types (0 to 9, \*, and #) of DTMF dial signals.
- DTMF signals are output consecutively for the keys pressed.
- A minimum DTMF output time of about 80 ms and a minimum IDP of 70 ms are assured.

**(2) Summary of operations**

- 16-digit 24-telephone number one-touch autodialing memory and 21-telephone number abbreviated dialing memory (common with one-touch dialing) and 63-digit redialing memory.
- The dialing data for each memory is read out at the prescribed dial rate and send out from the  $\overline{DP}$  or DTMF pin.
- In repertory memory (one-touch and abbreviated memory), when more than 16 digits are input for registration, the 17th and subsequent digits are ignored.
- If the dial output is more than 63 digits long, redialing is inhibited.
- Each memory can hold dial data (1 to 9, 0 \*, #), mode change data, hooking data, and pause data in each digit.
- Dial output is switched with the  $P/\overline{T}$  pin.
- The pause key (R/P) pauses the dial output for two seconds.
- Registered data can be sent out by accessing the appropriate memory.

**(3) Keys****① 0 to 9 keys**

- Dial data keys
- Abbreviated dialing addressing keys

**② \* and # keys**

- DTMF mode: \* and # dial data keys
- Pulse mode: invalid

**③ HK (hooking) key**

- Switches on DP output for 710 ms.
- A 1.0 second pause is automatically inserted, but the next dial data can be input during that time.
- During dialing output, input of this key is not accepted.

**④ M key (abbreviated dialing)**

- Sets the abbreviated dialing address.
- Abbreviated dialing is 3-touch, M00 to M20.

**⑤ R/P key (redial/pause)**

- The first time this key is pressed after the phone is put off-hook, it functions as the redial key. At any other time, it functions as the pause key.
- Redialing uses data before the HK data.
- The pause only operates during redialing and repertory memory.
- During redialing, input of this key is not accepted.

**⑥ PRIVACY ON/OFF (privacy)**

- Switches privacy mode on/off.

**⑦ A1 to A3 keys**

- These are one-touch dialing keys.
- These keys can not access abbreviated dialing memory.

**⑧ M00 to M20**

- These are one-touch dialing keys.
- These keys overlap with abbreviated dialing M00 to M20, so the memory can be accessed with either set of keys.

**(4) Pins****①  $P/\overline{T}$  pin**

- Dial mode specification input (H: pulse mode, L: DTMF mode)
- Mode changes are one direction, from pulse mode to DTMF mode.
- When the mode is switched during dialing, the mode change data is written into redial memory.

**② STORE IN pin**

- When this pin is high, the chip is in memory registration mode.



③ ON-HOOK DIAL IN pin

- When the OFF-HOOK pin is high, on-hook dial mode is switched ON/OFF at the falling edge of the signal at this pin.
- When the OFF-HOOK pin is low, monitor mode is switched ON/OFF at the falling edge of the signal at this pin.

④ OFF-HOOK pin

- HOOK switch input pin

⑤ ALARM-ENA pin

- When this pin is low, if an attempt is made to access a memory with nothing registered in it or a memory addressing mistake occurs, a 2072Hz 30ms sound is output five times.

⑥ SI/KEY pin

- Switches the key input between keyboard scan and serial input.
- Low: keyboard scan
- High: R1 to R5 and C1 to C8 are all pulled up and C6, C7, and C8 are the serial lock, serial data, and serial strobe, respectively. While C8 is low, this is the same state as when a key is being pressed.

⑦ OFF/ON STORE pin

- Switches the memory registration between ON-HOOK and OFF-HOOK.
- Low: ON-HOOK registration
- High: OFF-HOOK registration

⑧ DISCON IN pin

- Setting this pin low puts the chip into power down mode and switches off all output.
- At the rising edge of the signal at this pin, the entire LSI except the memory is initialized.

(5) Key debounce and pin chattering elimination time

① Key debounce time

Key input has a key debounce circuit to prevent malfunction due to switch chattering. When a key is held down continuously for 17.5 ms or longer, this is valid key input and if the key is released continuously for 17.5 ms or longer, the key is considered to have gone off.

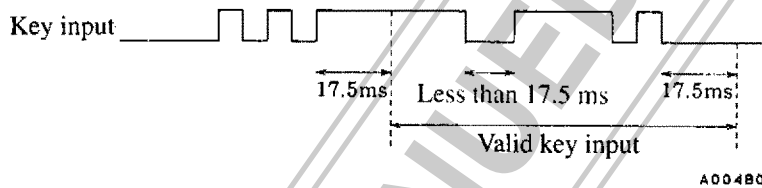

Pressing multiple keys

During valid input of one key, pressing another key is multiple pressing and is invalid. After this occurs, no key input will be accepted until you release all the keys for at least 17.5 ms.

② Pin chattering elimination time

Key input has a 30ms pin chattering elimination circuit to prevent malfunction due to switch chattering.

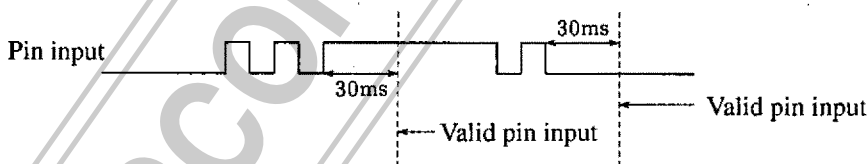

While the pin chattering elimination circuit is working, if there is input at another pin, the pin chattering elimination circuit is reset and 30 ms is counted before that pin input becomes valid.

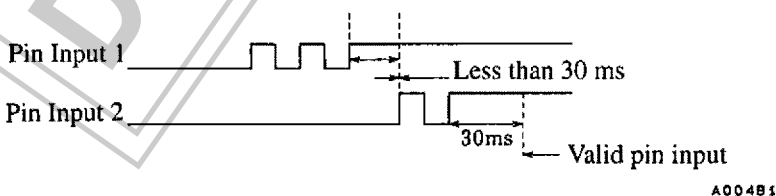

(6) Registering in each memory

- When the OFF/ON STORE pin is low, if the OFF-HOOK pin is set high or when the OFF/ON Store is high, if the OFF-HOOK pin is set low, then when the STORE-IN pin is set high, the chip goes into memory registration mode.
- In this mode, when a data key is pressed, the key verification sound is output and the data is written into memory.
- If the key verification sound is not output (for example because more than 16 digits have been input or because of invalid operation), then the key was not valid.
- When input of the data to be registered is complete, specify the memory address (a one-touch or abbreviation key). The registration confirmation sound (2072 Hz and 279 ms) is output.
- Setting the STORE-IN pin low takes the chip out of memory registration mode.

(7) Notes for dial specifications

- ① Normal dialing
  - If the mode is changed during pulse dial output and key-in of DTMF data starts, then after the completion of pulse dialing, an automatic pause of 1.0 second is inserted and DTMF signals are output after that pause.
  - If the mode is changed after pulse dial output and key-in of DTMF data starts, the DTMF signals are output when the keys are pressed.
  - After DTMF signal output, even if an attempt is made to output pulse data with the P/T pin, DTMF signals are output.
- ② One-touch and abbreviated dialing
  - If repertory memory registered with pulses is accessed right after the system goes OFF-HOOK, pulses are output (regardless of the P/T pin).
  - Pulse output mode ..... If the memory data is pulses, pulses are output; if the memory data is DTMF, DTMF signals are output.
  - DTMF output mode ..... DTMF signals are output whether the memory data is pulses or DTMF.
- ③ Pause operation
  - In normal dialing, if the Pause key is pressed a few times in a row during memory registration, that many pauses are registered into memory. However, these pauses are only effected for redial and repertory memory.
- ④ Hooking operation
  - Dialing output after hooking is in the same dial output mode as right after the system is put OFF-HOOK.
  - Only one digit of HK data is registered into memory.
- ⑤ Key input during redialing
  - Only the Privacy key is accepted during redialing; other keys are not accepted.
- ⑥ Key input during repertory memory dialing
  - The privacy key and repertory access are accepted.

Serial Data Timing

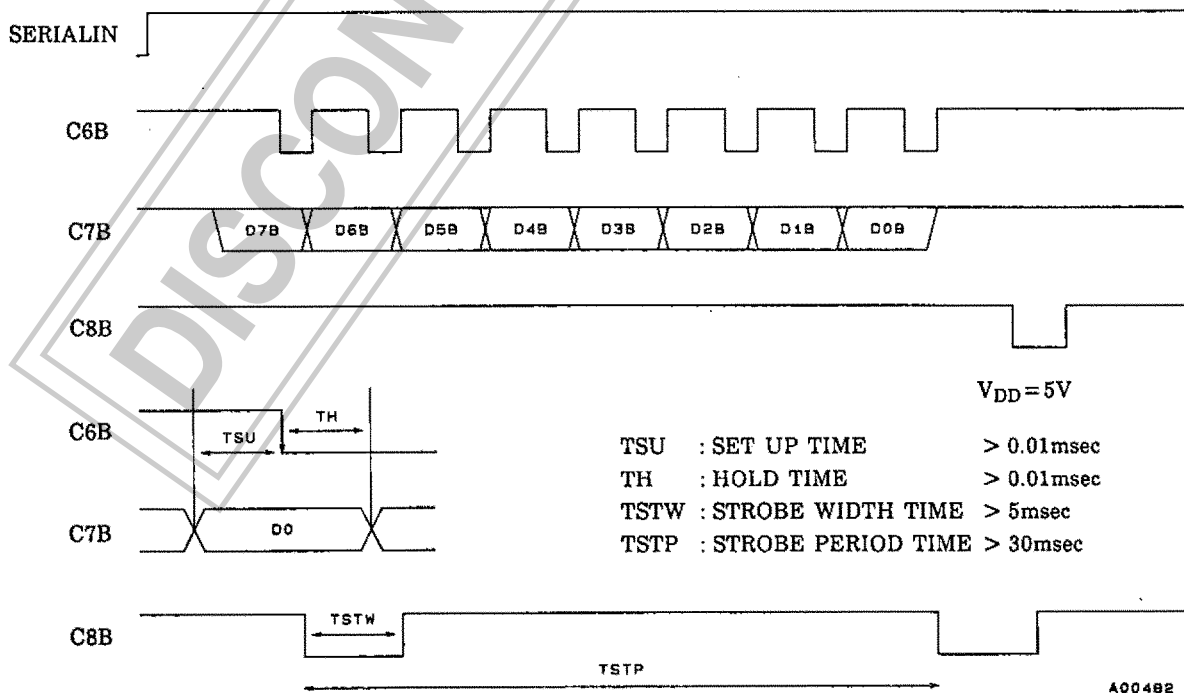

A00482

## ① PULSE DIAL

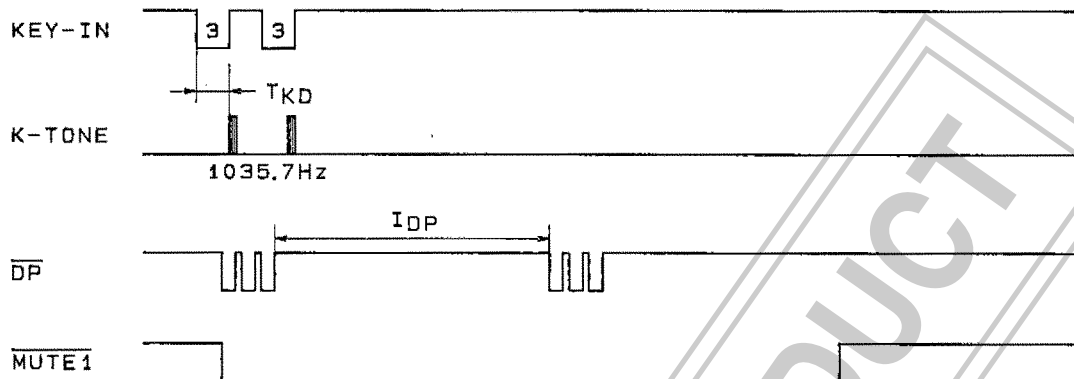

## ② DTMF DIAL

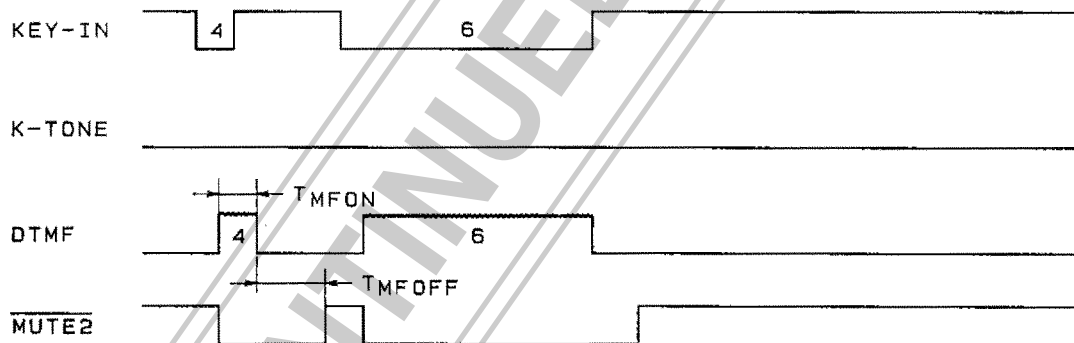

A01102

■ No products described or contained herein are intended for use in surgical implants, life-support systems, aerospace equipment, nuclear power control systems, vehicles, disaster/crime-prevention equipment and the like, the failure of which may directly or indirectly cause injury, death or property loss.

■ Anyone purchasing any products described or contained herein for an above-mentioned use shall:

- ① Accept full responsibility and indemnify and defend SANYO ELECTRIC CO., LTD., its affiliates, subsidiaries and distributors and all their officers and employees, jointly and severally, against any and all claims and litigation and all damages, cost and expenses associated with such use;
- ② Not impose any responsibility for any fault or negligence which may be cited in any such claim or litigation on SANYO ELECTRIC CO., LTD., its affiliates, subsidiaries and distributors or any of their officers and employees jointly or severally.

■ Information (including circuit diagrams and circuit parameters) herein is for example only; it is not guaranteed for volume production. SANYO believes information herein is accurate and reliable, but no guarantees are made or implied regarding its use or any infringements of intellectual property rights or other rights of third parties.

LC73720

Serial in Data

KEY	ROW	COL	D7	D6	D5	D4	D3	D2	D1	D0	HEX	
1	1	1	1	0	0	0	0	0	0	1	8	1
2	1	2	1	0	0	0	0	0	1	0	8	2
3	1	3	1	0	0	0	0	0	1	1	8	3
4	2	1	1	0	0	0	0	1	0	0	8	4
5	2	2	1	0	0	0	0	1	0	1	8	5
6	2	3	1	0	0	0	0	1	1	0	8	6
7	3	1	1	0	0	0	0	1	1	1	8	7
8	3	2	1	0	0	0	1	0	0	0	8	8
9	3	3	1	0	0	0	1	0	0	1	8	9
0	4	2	1	0	0	0	1	0	1	0	8	A
*	4	1	1	0	0	1	1	0	1	1	9	B
#	4	3	1	0	0	1	1	1	0	0	9	C
HK	1	4	1	0	1	0	0	0	0	0	A	0
P			1	0	1	0	0	0	0	1	A	1
MC			1	0	1	0	0	0	1	0	A	2
RD			0	1	0	0	0	1	0	0	4	4
M	2	4	0	1	0	0	0	1	0	1	4	5
CLR			0	1	0	0	0	1	1	1	4	6
PRI	4	4	0	1	0	0	0	1	1	1	4	7
R/P	3	4	0	1	1	0	1	0	0	1	6	9
M00	5	4	0	0	0	0	0	0	0	0	0	0
M01	1	8	0	0	0	0	0	0	0	1	0	1
M02	2	8	0	0	0	0	0	0	1	0	0	2
M03	3	8	0	0	0	0	0	0	1	1	0	3
M04	4	8	0	0	0	0	0	1	0	0	0	4
M05	5	8	0	0	0	0	0	1	0	1	0	5
M06	1	7	0	0	0	0	0	1	1	0	0	6
M07	2	7	0	0	0	0	0	1	1	1	0	7
M08	3	7	0	0	0	0	1	0	0	0	0	8
M09	4	7	0	0	0	0	1	0	0	1	0	9
M10	5	7	0	0	0	1	0	0	0	0	1	0
M11	1	6	0	0	0	1	0	0	0	1	1	1
M12	2	6	0	0	0	1	0	0	1	0	1	2
M13	3	6	0	0	0	1	0	0	1	1	1	3
M14	4	6	0	0	0	1	0	1	0	0	1	4
M15	5	6	0	0	0	1	0	1	0	1	1	5
M16	1	5	0	0	0	1	0	1	1	0	1	6
M17	2	5	0	0	0	1	0	1	1	1	1	7
M18	3	5	0	0	0	1	1	0	0	0	1	8
M19	4	5	0	0	0	1	1	0	0	1	1	9
M20	5	5	0	0	1	0	0	0	0	0	2	0
A1	5	1	0	0	1	1	0	0	0	1	3	1
A2	5	2	0	0	1	1	0	0	1	0	3	2
A3	5	3	0	0	1	1	0	0	1	1	3	3