

DATA SHEET

TDA9141 PAL/NTSC/SECAM decoder/sync processor

Product specification
File under Integrated Circuits, IC02

December 1992

PAL/NTSC/SECAM decoder/sync processor**TDA9141****FEATURES**

- Multistandard PAL, NTSC and SECAM
- I²C-bus controlled
- I²C-bus addresses can be selected by hardware
- Alignment free
- Few external components
- Designed for use with baseband delay lines
- Integrated video filters
- CVBS or YC input with automatic detection
- CVBS output
- Vertical divider system
- Two-level sandcastle signal
- V_A synchronization pulse (3-state)
- H_A synchronization pulse or clamping pulse CLP input/output
- Line-locked clock output or stand-alone I²C-bus output port
- Stand-alone I²C-bus input/output port
- Colour matrix and fast YUV switch
- Comb filter enable input/output with subcarrier frequency.

**GENERAL DESCRIPTION**

The TDA9141 is an I²C-bus controlled, alignment-free PAL/NTSC/SECAM decoder/sync processor. The TDA9141 has been designed for use with baseband chrominance delay lines, and has a combined subcarrier frequency/comb filter enable signal for communication with a PAL comb filter.

The IC can process CVBS signals and Y/C input signals. The input signal is available on an output pin, in the event of a Y/C signal, it is added into a CVBS signal.

The sync processor provides a two-level sandcastle, a horizontal pulse (CLP or H_A pulse, bus selectable) and a vertical (V_A) pulse. When the H_A pulse is selected a line-locked clock (LLC) signal is available at the output port pin.

A fast switch can select either the internal Y signal with the UV input signals, or YUV signals made of the RGB input signals. The RGB input signals can be clamped with either the internal or an external clamping signal (search tuning mode).

Two pins with an input/output port and an output port of the I²C-bus are available.

The I²C-bus address of the TDA9141 is hardware programmable.

ORDERING INFORMATION

EXTENDED TYPE NUMBER	PACKAGE			
	PINS	PIN POSITION	MATERIAL	CODE
TDA9141	32	SDIL	plastic	SOT232 ⁽¹⁾

Note

1. SOT232-1; 1996 December 4.

PAL/NTSC/SECAM decoder/sync processor

TDA9141

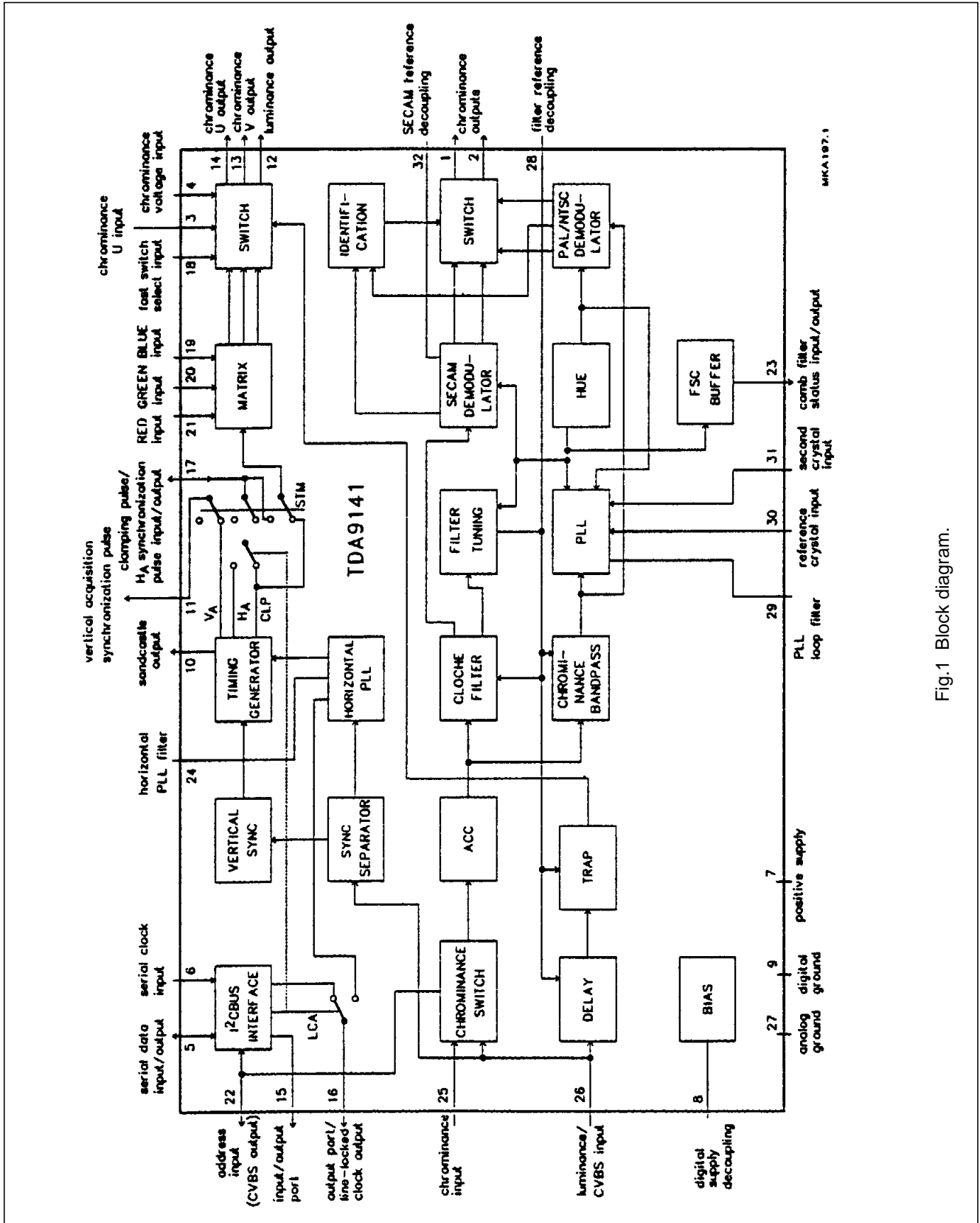

Fig.1 Block diagram.

PAL/NTSC/SECAM decoder/sync processor

TDA9141

QUICK REFERENCE DATA

SYMBOL	PARAMETER	CONDITIONS	MIN.	TYP.	MAX.	UNIT
V _{CC}	positive supply voltage		7.2	8.0	8.8	V
I _{CC}	supply current		–	45	–	mA
V _{26(p-p)}	CVBS input voltage (peak-to-peak value)	top sync - white	–	1.0	–	V
V _{26(p-p)}	luminance input voltage (peak-to-peak value)	top sync - white	–	1.0	–	V
V _{22(p-p)}	chrominance burst input voltage (peak-to-peak value)		–	0.3	–	V
V ₁₂	luminance black-white output voltage		–	1.0	–	V
V _{14(p-p)}	U output voltage (peak-to-peak value)	standard colour bar	–	1.33	–	V
V _{13(p-p)}	V output voltage (peak-to-peak value)	standard colour bar	–	1.05	–	V
V ₁₀	sandcastle blanking voltage level		–	2.5	–	V
V ₁₀	sandcastle clamping voltage level		–	4.5	–	V
V ₁₁	V _A output voltage		–	5.0	–	V
V ₁₇	H _A output voltage		–	5.0	–	V
V _{16(p-p)}	LLC output voltage amplitude (peak-to-peak value)		–	500	–	mV
V _{21,20 19(p-p)}	RGB input voltage (peak-to-peak value)	0 to 100% saturation	–	0.7	–	V
V _{clamp I/O}	clamping pulse input/output voltage		–	5.0	–	V
V _{sub}	subcarrier output voltage amplitude (peak-to-peak value)		–	200	–	mV
V _{15,16}	O port output voltage		–	5.0	–	V

PAL/NTSC/SECAM decoder/sync processor

TDA9141

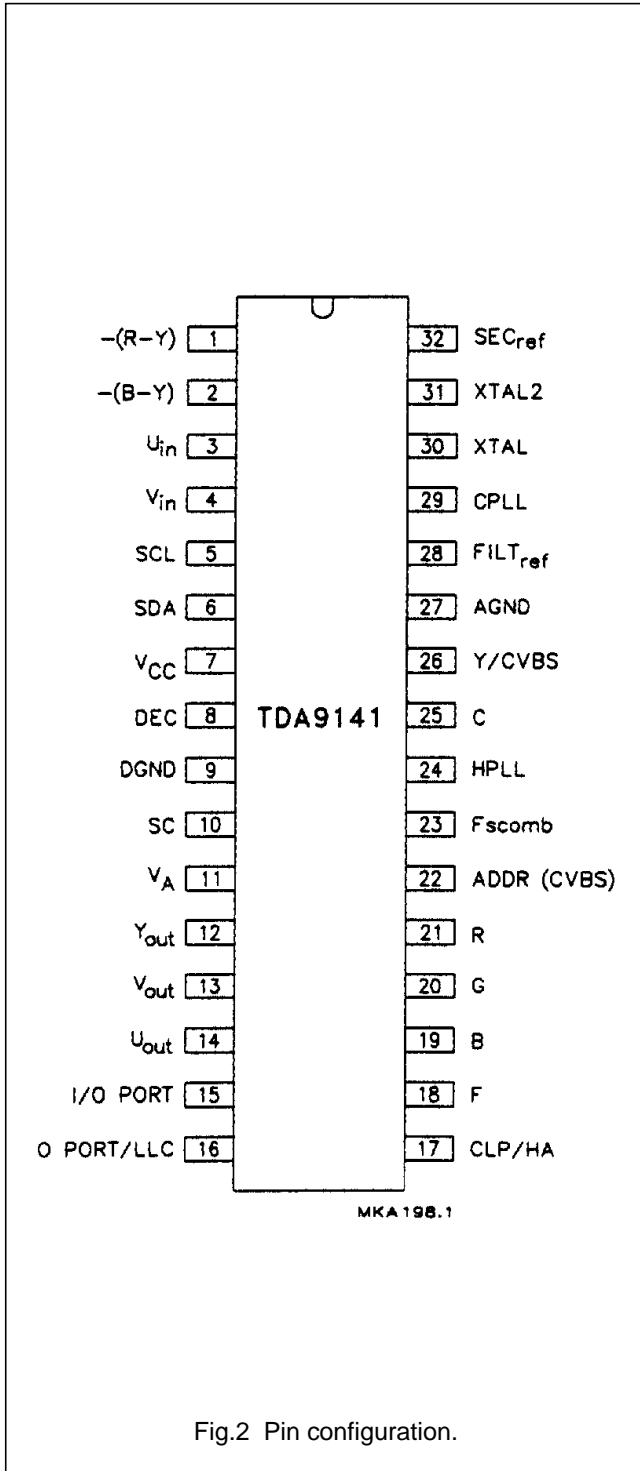

Fig.2 Pin configuration.

PINNING

SYMBOL	PIN	DESCRIPTION
-(R-Y)	1	chrominance output
-(B-Y)	2	chrominance output
U _{in}	3	chrominance U input
V _{in}	4	chrominance voltage input
SCL	5	serial clock input
SDA	6	serial data input/output
V _{CC}	7	positive supply input
DEC	8	digital supply decoupling
DGND	9	digital ground
SC	10	sandcastle output
V _A	11	vertical acquisition synchronization pulse
Y _{out}	12	luminance output
V _{out}	13	chrominance V output
U _{out}	14	chrominance U output
I/O PORT	15	input/output port
O PORT/LLC	16	output port/line-locked clock output
CLP/HA	17	clamping pulse/H _A synchronization pulse input/output
F	18	fast switch select input
B	19	BLUE input
G	20	GREEN input
R	21	RED input
ADDR (CVBS)	22	I ² C-bus address input (CVBS output)
Fscomb	23	comb filter status input/output
HPLL	24	horizontal PLL filter
C	25	chrominance input
Y/CVBS	26	luminance/CVBS input
AGND	27	analog ground
FILT _{ref}	28	filter reference decoupling
CPLL	29	colour PLL filter
XTAL	30	reference crystal input
XTAL2	31	second crystal input
SEC _{ref}	32	SECAM reference decoupling

PAL/NTSC/SECAM decoder/sync processor

TDA9141

FUNCTIONAL DESCRIPTION

General

The TDA9141 is an I²C-bus controlled, alignment-free PAL/NTSC/SECAM colour decoder/sync processor which has been designed for use with baseband chrominance delay lines.

In the standard operating mode the I²C-bus address is 8A. If the address input is connected to the positive rail the address will change to 8E.

Input switch

WARNING: THE VOLTAGE ON THE CHROMINANCE PIN MUST NEVER EXCEED 5.5 V. IF IT DOES THE IC ENTERS A TEST MODE.

The TDA9141 has a two pin input for CVBS or YC signals which can be selected via the I²C-bus. The input selector also has a position in which it automatically detects whether a CVBS or YC signal is on the input. In this input selector position, standard identification first takes place on an added Y/CVBS and C input signal. After that, both chrominance signal input amplitudes are checked once and the input with the strongest chrominance burst signal is selected. The input switch status is read out by the I²C-bus via output bit YC.

CVBS output

In the standard operating mode with the I²C-bus address 8A, a CVBS output signal is available on the address pin, which represents either the CVBS input signal or the Y/C input signal, added into a CVBS signal

RGB colour matrix

WARNING: THE VOLTAGE ON THE UIN PIN MUST NEVER EXCEED 5.5 V. IF IT DOES THE IC ENTERS A TEST MODE.

The TDA9141 has a colour matrix to convert RGB input signals into YUV signals. A fast switch, controlled by

the signal on pin F and enabled by the I²C-bus via EFS (enable fast switch), can select between these YUV signals and the YUV signals of the decoder. The Y signal is internally connected to the switch. The $-(R-Y)$ and $-(B-Y)$ output signals of the decoder have to first be delayed in external baseband chrominance delay lines. The outputs of the delay lines must be connected to the UV input pins. If the RGB signals are not synchronous with the selected decoder input signal, clamping of the RGB input signals is possible by I²C-bus selection of STM (search tuning mode), EFS and by feeding an external clamping signal to the CLP pin.

Also in search tuning mode the VA output will be in a high impedance OFF-state.

Standard identification

The standards which the TDA9141 can decode are dependent on the choice of external crystals. If a 4.4 MHz and a 3.6 MHz crystal are used then SECAM, PAL 4.4/3.6 and NTSC 4.4/3.6 can be decoded. If two 3.6 MHz crystals are used then only PAL 3.6 and NTSC 3.6 can be decoded. Which 3.6 MHz standards can be decoded is dependent on the exact frequencies of the 3.6 MHz crystals. In an application where not all standards are required only one crystal is sufficient (in this instance the crystal must be connected to the reference crystal input (pin 30)). If a 4.4 MHz crystal is used it must always be connected to pin 30. Both crystals are used to provide a reference for the filters and the horizontal PLL, however, only the reference crystal is used to provide a reference for the SECAM demodulator.

To enable the calibrating circuits to be adjusted exactly two bits from I²C-bus subaddress 00 are used to indicate which crystals are connected to the IC.

The standard identification circuit is a digital circuit without external components; the search loop is illustrated in Fig.3.

The decoder (via the I²C-bus) can be forced to decode either SECAM or PAL/NTSC (but not PAL or NTSC). Crystal selection can also be forced. Information concerning which standard and which crystal have been selected and whether the colour killer is ON or OFF is provided by the read out. Using the forced-mode does not affect the search loop, it does, however, prevent the decoder from reaching or staying in an unwanted state. The identification circuit skips impossible standards (e.g. SECAM when no 4.4 MHz crystal is fitted) and illegal standards (e.g. is forced mode). To reduce the risk of wrong identification PAL has priority over SECAM (only line identification is used for SECAM).

Integrated filters

All filters, including the luminance delay line, are an integral part of the IC. The filters are gyrator-capacitor type filters. The resonant frequency of the filters is controlled by a circuit that uses the active crystal to tune the SECAM Cloche filter during the vertical flyback time. The remaining filters and the luminance delay line are matched to this filter. The filters can be switched to either 4.43 MHz, 4.28 MHz or 3.58 MHz irrespective of the frequency of the active crystal. The switching is controlled by the identification circuit.

In YC mode the chrominance notch filter is bypassed, to preserve full signal bandwidth.

For a CVBS signal the chrominance notch filter can be bypassed by I²C-bus selection of TB (trap bypass). The luminance delay line delivers the Y signal to the output 60 ns after the $-(R-Y)$ and $-(B-Y)$ signals have arrived at their outputs.

PAL/NTSC/SECAM decoder/sync processor

TDA9141

This compensates for the delay of the external chrominance delay lines.

Colour decoder

The PAL/NTSC demodulator employs an oscillator that can operate with either crystal (3.6 or 4.4 MHz). If the I²C-bus indicates that only one crystal is connected it will always connect to the crystal on the reference crystal input (pin 30).

The Hue signal, which is adjustable via the I²C-bus, is gated during the burst for NTSC signals.

The SECAM demodulator is an auto-calibrating PLL demodulator which has two references. The reference crystal, to force the PLL to the desired free-running frequency and the bandgap reference, to obtain the correct absolute value of the output signal. The VCO of the PLL is calibrated during each vertical blanking period, when the IC is in search mode or SECAM mode. If the reference crystal is not 4.4 MHz the decoder will not produce the correct SECAM signals.

The frequency of the active crystal is fed to the Fscomb output, which can be connected to an external comb filter IC. The DC value on this pin contains the comb enable information. Comb enable is true when bus bit ECMB is HIGH. If ECMB is LOW, the subcarrier frequency is suppressed. The external comb filter can force the DC value of Fscomb LOW, as pin Fscomb also acts as input pin. In this event the subcarrier frequency is still present. If the DC value of Fscomb is HIGH, the input switch is always forced in Y/C mode, indicated by bus bit YC.

Sync processor ($\phi 1$ loop)

The main part of the sync circuit is a $432 \times f_H$ (6.75 MHz) oscillator the frequency of which is divided by 432 to lock the Phase 1 loop to the incoming signal. The time constant of the loop can be forced by the I²C-bus (fast or slow). If required the IC can select the time constant, depending on the noise content of the input signal and whether the loop is phase-locked or not (medium or slow). The free-running frequency of the oscillator is determined by a digital control circuit that is locked to the active crystal.

When a power-on-reset pulse is detected the frequency of the oscillator is switched to a frequency greater than 6.75 MHz to protect the horizontal output transistor. The oscillator frequency is reset to 6.75 MHz when the crystal indication bits have been loaded into the IC. To ensure that this procedure does not fail it is absolutely necessary to send subaddress 00 before subaddress 01. Subaddress 00 contains the crystal indication bits and when subaddress 01 is received the line oscillator calibration will be initiated (for the start-up procedure after power-on reset detection see the I²C-bus protocol). The calibration is terminated when the oscillator frequency reaches 6.75 MHz. The oscillator is again calibrated when an out-of-lock condition with the input signal is detected by the coincidence detector. Again the calibration will be terminated when the oscillator frequency reaches 6.75 MHz. The Phase 1 loop can be opened using the I²C-bus. This is to facilitate On Screen Display (OSD) information. If there is no input signal or a very noisy input signal the phase 1 loop can be opened to provide a stable line frequency and thus a stable picture.

The sync part also delivers a two-level sandcastle signal, which provides a combined horizontal and vertical blanking signal and a clamping pulse for the display section of the TV.

Vertical divider system

The vertical divider system has a fully integrated vertical sync separator. The divider can accommodate both 50 and 60 Hz systems; it can either locate the field frequency automatically or it can be forced to the desired system via the I²C-bus. A block diagram of the vertical divider system is illustrated in Fig.4. The divider system operates at twice the horizontal line frequency. The line counter receives enable pulses at this line frequency, thereby counting two pulses per line.

A state diagram of the controller is illustrated in Fig.5. Because it is symmetrical only the right hand part will be described.

Depending on the previously found field frequency, the controller will be in one of the COUNT states. When the line counter has counted 488 pulses (i.e. 244 lines of the video input signal) the controller will move to the next state depending on the output of the norm counter. This can be either NORM, NEAR_NORM or NO_NORM depending on the position of the vertical sync pulse in the previous fields. When the controller is in the NORM state it generates the vertical sync pulse (VSP) automatically and then, when the line counter is at $LC = 626$, moves to the WAIT state. In this condition it waits for the next pulse of the double line frequency signal and then moves to the COUNT state of the current field frequency. When the controller returns to the COUNT state the line counter will be reset half a line after the start of the vertical sync pulse of the video input signal.

PAL/NTSC/SECAM decoder/sync processor

TDA9141

When the controller is in the NEAR_NORM state it will move to the COUNT state if it detects the vertical sync pulse within the NEAR_NORM window (i.e. $622 < LC < 628$). If no vertical sync pulse is detected, the controller will move back to the COUNT state when the line counter reaches $LC = 628$. The line counter will then be reset.

When the controller is in the NO_NORM state it will move to the COUNT state when it detects a vertical sync pulse and reset the line counter. If a vertical sync pulse is not detected before $LC = 722$ (if the Phase 1 loop is locked in forced mode) it will move to the COUNT state and reset the line counter. If the Phase 1 loop is not locked the controller will move back to the COUNT state when $LC = 628$. The forced mode option keeps the

controller in either the left-hand side (60 Hz) or the right-hand side (50 Hz) of the state diagram.

Figure 6 illustrates the state diagram of the norm counter which is an up/down counter that counts up if it finds a vertical sync pulse within the selected window. In the NEAR_NORM and NORM states the first correct vertical sync pulse after one or more incorrect vertical sync pulses is processed as an incorrect pulse. This procedure prevents the system from staying in the NEAR_NORM or NORM state if the vertical sync pulse is correct in the first field and incorrect in the second field. If no vertical sync pulse is found in the selected window this will always result in a down pulse for the norm counter.

Output port and input/output port

Two stand-alone ports are available for external use. These ports are I²C-bus controlled, the output port by bus bit OPB and the input/output port by bus bit OPA. Bus bit OPA is an open-drain output, to enable input port functioning. The pin status is read out by bus via output bit IP.

Sandcastle

Figure 7 illustrates the timing of the acquisition sandcastle (ASC) and the V_A pulse with respect to the input signal. The sandcastle signal is in accordance with the 2-level 5 V sandcastle format. An external vertical guard current can overrule the sink current to enable blanking purposes.

PAL/NTSC/SECAM decoder/sync processor

TDA9141

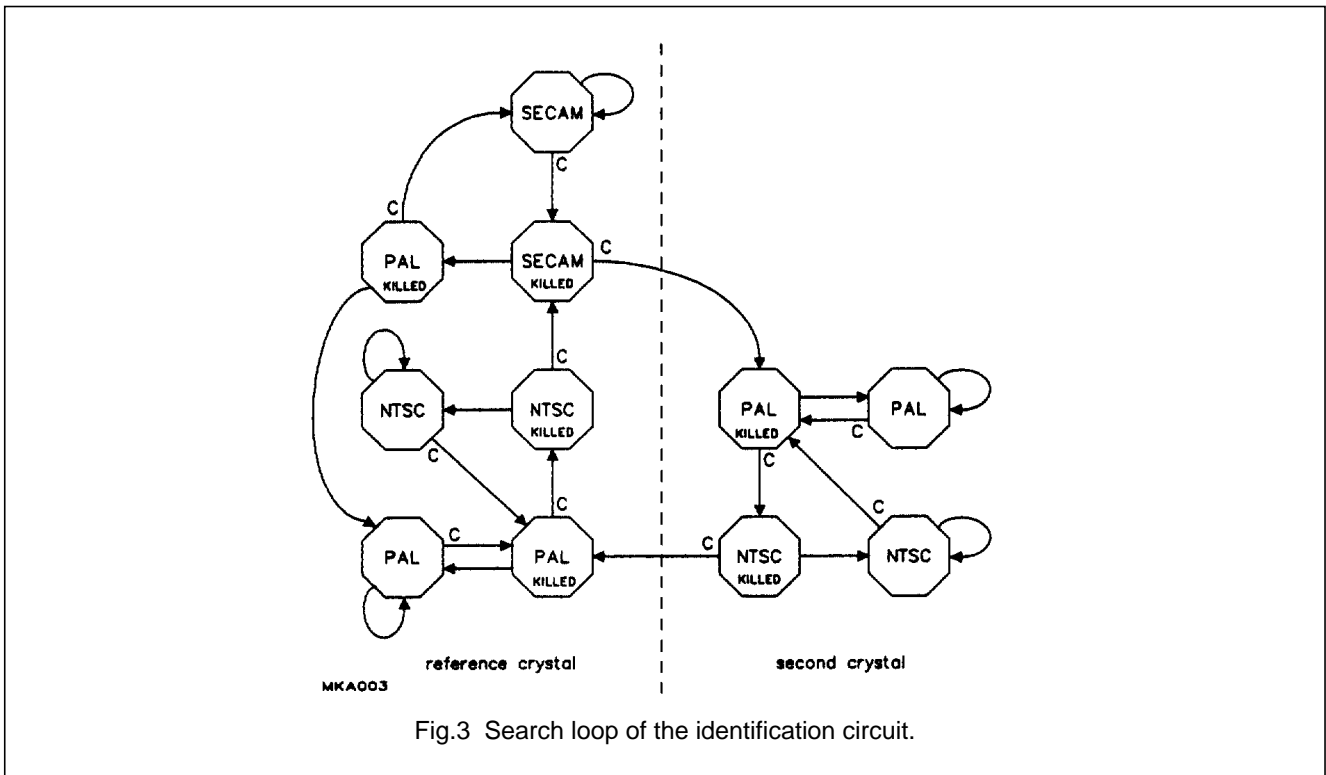

Fig.3 Search loop of the identification circuit.

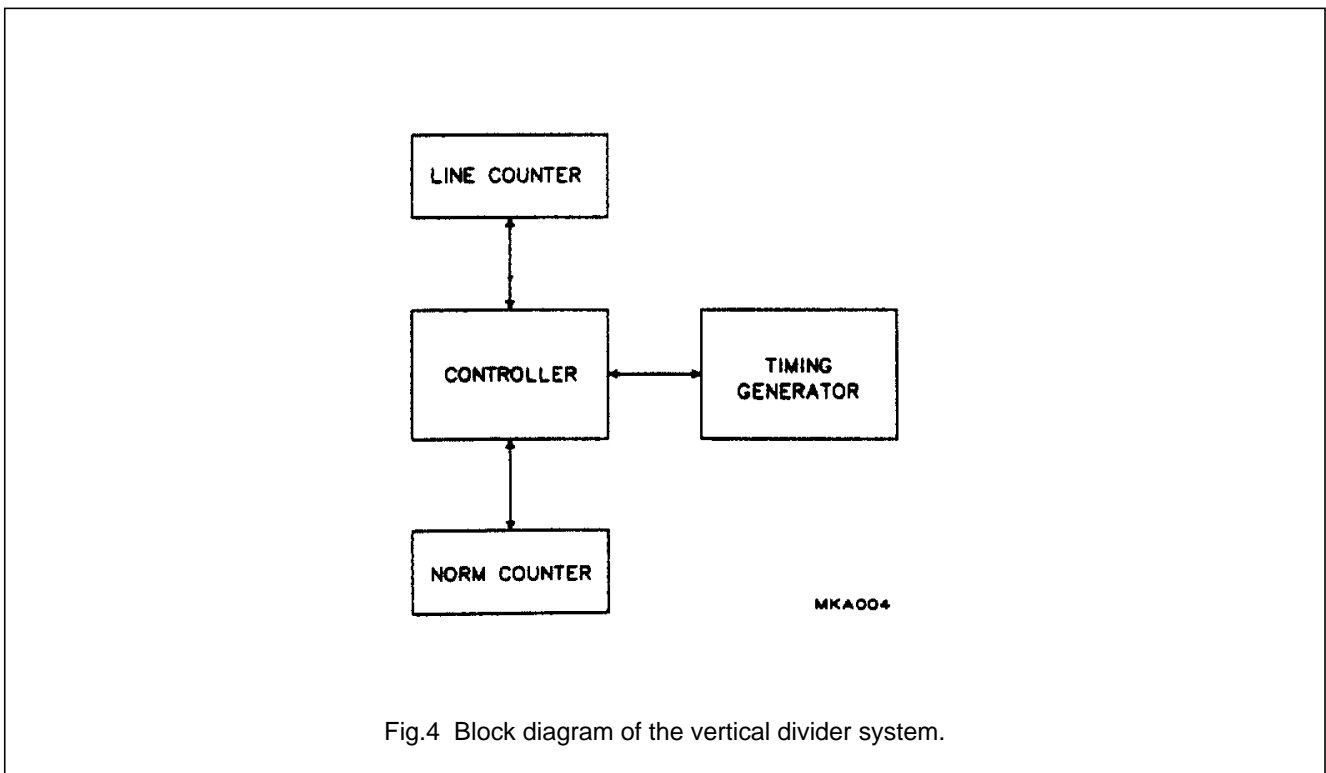

Fig.4 Block diagram of the vertical divider system.

PAL/NTSC/SECAM decoder/sync processor

TDA9141

Table 1 Slave address (8A).

A6	A5	A4	A3	A2	A1	A0	R/W
1	0	0	0	1	X	1	X

Table 2 Inputs.

SUBADDRESS	MSB							LSB
00	INA	INB	TB	ECMB	FOA	FOB	XA	XB
01	FORF	FORS	OPA	OPB	POC	FM	SAF	FRQF
02	EFS	STM	HU5	HU4	HU3	HU2	HU1	HU0
03	LCA	–	–	–	–	–	–	–

Table 3 Outputs.

ADDRESS	POR	FSI	YC	SL	IP	SAK	SBK	FRQ

I²C-bus protocol

If the address input is connected to the positive supply the address will change from 8A to 8E.

Valid subaddresses = 00 to 0F

Auto-increment mode available for subaddresses.

Start-up procedure: read the status byte until POR = 0; send subaddress 00 with the crystal indicator bits (XA and XB) indicating that only one crystal is connected to the IC; wait for 250 ms; send subaddress 01; wait for at least 100 ms; set XA, XB to the actual crystal configuration.

Each time before the data in the IC is refreshed, the status byte must be read. If POR = 1, then the above procedure must be carried out to restart the IC.

Failure to stick to the above procedure may result in an incorrect line frequency after power-up or a power-dip.

PAL/NTSC/SECAM decoder/sync processor

TDA9141

INPUT SIGNALS**Table 4** Source select.

INA	INB	SOURCE
0	0	CVBS
0	1	YC
1	–	auto CVBS/YC

Table 5 Trap bypass.

TB	CONDITION
0	trap not bypassed
1	trap bypassed

Table 6 Comb filter enable.

ECMB	CONDITION
0	comb filter disabled
1	comb filter enabled

Table 7 Phase 1 time constant.

FOA	FOB	MODE
0	0	auto
0	1	slow
1	–	fast

Table 8 Crystal indication.

XA	XB	CRYSTAL
0	0	2 x 3.6 MHz
0	1	1 x 3.6 MHz
1	0	1 x 4.4 MHz
1	1	3.6 and 4.4 MHz

Table 9 Forced field frequency.

FORF	FORS	FIELD FREQUENCY
0	0	auto; 60 Hz if no lock
0	1	60 Hz
1	0	50 Hz
1	1	auto; 50 Hz if no lock

Table 10 Output value I/O port.

OPA	CONDITION
0	LOW
1	HIGH

Table 11 Output value O port.

OPB	CONDITION
0	LOW
1	HIGH

Table 12 Phase 1 loop control.

POC	CONDITION
0	phase one loop closed
1	phase one loop open

Table 13 Forced standard.

FM	SAF	FRQF	STANDARD
0	–	–	auto search
1	0	0	PAL/NTSC second crystal
1	0	1	PAL/NTSC reference crystal
1	1	0	illegal
1	1	1	SECAM reference crystal

Note to table 13

1. If XA and XB indicate that only one crystal is connected to the IC and FM and FRQF force it to use the second crystal the colour will be switched off.

PAL/NTSC/SECAM decoder/sync processor

TDA9141

Table 14 Fast switch enable.

EFS	CONDITION
0	fast switch disabled
1	fast switch enabled

Table 15 Search tuning mode.

STM	CONDITION
0	search tuning mode off
1	search tuning mode on

Table 16 Hue.

FUNCTION	ADDRESS	DIGITAL NUMBER
hue	HU5 to HU0	000000 = -45° 111111 = $+45^\circ$

Table 17 Line-locked clock active.

LCA	CONDITION
0	OPB/CLP mode
1	LLC/HA mode

OUTPUT SIGNALS**Table 18** Power-on reset.

POR	CONDITION
0	normal mode
1	power-down mode

Table 19 Field frequency indication.

FSI	CONDITION
0	50 Hz
1	60 Hz

Table 20 Input switch mode.

YC	CONDITION
0	CVBS mode
1	YC mode

Table 21 Phase 1 lock indication.

SL	CONDITION
0	not locked
1	locked

Table 22 Input value I/O port.

IP	CONDITION
0	LOW
1	HIGH

Table 23 Standard read-out.

SAK	SBK	FRQ	STANDARD
0	0	0	PAL second crystal
0	0	1	PAL reference crystal
0	1	0	NTSC second crystal
0	1	1	NTSC reference crystal
1	0	0	illegal forced mode
1	0	1	SECAM reference crystal
1	1	–	colour off

PAL/NTSC/SECAM decoder/sync processor

TDA9141

LIMITING VALUES

In accordance with the Absolute Maximum Rating System. (IEC134)

SYMBOL	PARAMETER	CONDITIONS	MIN.	MAX.	UNIT
V _{CC}	positive supply voltage		–	8.8	V
I _{CC}	supply current		–	60	mA
P _{tot}	total power dissipation		–	530	mW
T _{stg}	storage temperature		–55	+150	°C
T _{amb}	operating ambient temperature		–10	+65	°C
ESD	electrostatic discharge (on all pins)				
	Human body model	note 1	–2000	+2000	V
	Machine model	note 2	–200	+200	V

Notes to the limiting values

1. Equivalent to discharging a 100 pF capacitor via a 1.5 k Ω series resistor.
2. Equivalent to discharging a 200 pF capacitor via a 0 Ω series resistor.

THERMAL RESISTANCE

SYMBOL	PARAMETER	THERMAL RESISTANCE
R _{th j-a}	from junction to ambient in free air	48 K/W

PAL/NTSC/SECAM decoder/sync processor

TDA9141

CHARACTERISTICS $V_{CC} = 8\text{ V}$; $T_{amb} = 25\text{ °C}$; unless otherwise specified.

SYMBOL	PARAMETER	CONDITIONS	MIN.	TYP.	MAX.	UNIT
Supply						
V_{CC}	positive supply voltage		7.2	8.0	8.8	V
I_{CC}	supply current		–	45	–	mA
P_{tot}	total power dissipation		–	360	–	mW
Input switch						
Y/CVBS INPUT (PIN 26)						
$V_{26(p-p)}$	input voltage (peak-to-peak value)	top sync - white	–	1.0	1.43	V
Z_I	input impedance		60	–	–	k Ω
C INPUT (PIN 25)						
$V_{25(p-p)}$	input burst voltage (peak-to-peak value)		–	0.3	0.43	V
Z_I	input impedance		60	–	–	k Ω
CVBS OUTPUT (PIN 22) ONLY ADDRESS 8A						
$V_{22(p-p)}$	output voltage (peak-to-peak value)	top sync - white	–	1.0	–	V
Z_O	output impedance		–	–	500	Ω
V_{tsl}	top sync voltage level		–	2.8	–	V
Bias generator (pin 8)						
V_8	digital supply voltage		–	5.0	–	V
Subcarrier regeneration						
GENERAL						
CR	catching range reference crystal 4.4 MHz reference crystal 3.6 MHz second crystal 3.6 MHz	note 1	± 400 tbf ± 300	– – –	– – –	Hz Hz Hz
ϕ	phase shift for 400 Hz deviation for 300 Hz deviation	4.4 MHz 3.6 MHz	– –	– –	5 5	deg deg
TC	temperature coefficient of oscillator		–	tbf	–	Hz/K
Z_I	input impedance reference crystal input second crystal input		– –	1.0 1.5	– –	k Ω k Ω
V_{dep}	supply voltage dependency		–	tbf	–	V
FSCOMB OUTPUT (PIN 23)						
$V_{sub(p-p)}$	subcarrier output amplitude (peak-to-peak value)	$C_L = 15\text{ pF}$	150	200	300	mV
V_{cen}	comb enable voltage level		4.0	4.2	–	V
V_{cdis}	comb disable voltage level		–	0.8	1.4	V

PAL/NTSC/SECAM decoder/sync processor

TDA9141

SYMBOL	PARAMETER	CONDITIONS	MIN.	TYP.	MAX.	UNIT
I_{sink}	minimum sink current to force output to comb disable level		0.4	–	2.0	mA
R_{GND}	value of grounded resistor to force output to comb disable level		0.4	–	2.0	k Ω
ACC						
	ACC control range		–20	–	+5	dB
	change of –(R–Y) and –(B–Y) signals over ACC range		–	–	1	dB
	colour killer threshold		–	–25	–	dB
	PAL/NTSC		–	–23	–	dB
	SECAM		–	–23	–	dB
	kill - unkill hysteresis		–	3	–	dB
Demodulators –(R–Y) and –(B–Y) outputs (pins 1 and 2)						
	ratio of –(R–Y) and –(B–Y) signals	standard colour bar	1.20	1.27	1.34	
TC	temperature coefficient of –(R–Y) and –(B–Y) amplitude		–	tbf	–	Hz/K
	spread of –(R–Y) and –(B–Y) ratio between standards		–1	–	+1	dB
V_1	output level of –(R–Y) during blanking		–	2.0	–	V
V_2	output level of –(B–Y) during blanking		–	2.0	–	V
B	–3 dB bandwidth		–	1	–	MHz
Z_O	output impedance		–	–	500	Ω
V_{dep}	supply voltage dependency		–	tbf	–	V
PAL/NTSC DEMODULATOR						
$V_{1(p-p)}$	–(R–Y) output voltage (peak-to-peak value)	standard colour bar	470	525	585	mV
$V_{2(p-p)}$	–(B–Y) output voltage (peak-to-peak value)	standard colour bar	595	665	740	mV
α	crosstalk between –(R–Y) and –(B–Y)		–	tbf	–	dB
$V_{1,2(p-p)}$	8.8 MHz residue (peak-to-peak value)	both outputs	–	–	15	mV
$V_{1,2(p-p)}$	7.2 MHz residue (peak-to-peak value)	both outputs	–	–	20	mV
PAL DEMODULATOR						
$V_{R(p-p)}$	H/2 ripple (peak-to-peak value)		–	–	50	mV
S/N	signal-to-noise ratio		46	–	–	dB
NTSC DEMODULATOR						
φ	hue phase shift		–	± 45	–	deg
SECAM DEMODULATOR						
$V_{1(p-p)}$	–(R–Y) output voltage (peak-to-peak value)	standard colour bar	0.94	1.05	1.17	V
$V_{2(p-p)}$	–(B–Y) output voltage (peak-to-peak value)	standard colour bar	1.19	1.33	1.48	V
f_{os}	black level offset		–	–	7	kHz
S/N	signal-to-noise ratio		–	43	–	dB

PAL/NTSC/SECAM decoder/sync processor

TDA9141

SYMBOL	PARAMETER	CONDITIONS	MIN.	TYP.	MAX.	UNIT
$V_{res(p-p)}$	7.8 to 9.4 MHz residue (peak-to-peak value)		–	–	30	mV
f_{pole}	pole frequency of de-emphasis		77	85	93	kHz
	ratio of pole and zero frequency		–	3	–	
V_{cal}	calibration voltage		3	4	5	V
NL	non linearity		–	–	3	%
Filters						
TUNING						
V_{tune}	tuning voltage		1.5	3.0	6.0	V
LUMINANCE DELAY						
t_d	delay time		–	480	–	ns
	PAL/NTSC		–	480	–	ns
	SECAM		–	480	–	ns
	B/W		–	220	–	ns
CHROMINANCE TRAP						
f_O	notch frequency	$f_{SC} = 3.6$ MHz	3.53	3.58	3.63	MHz
		$f_{SC} = 4.4$ MHz	4.37	4.43	4.49	MHz
		SECAM	4.23	4.29	4.35	MHz
		YC mode; not active				
B	bandwidth at –3 dB	$f_{SC} = 3.6$ MHz	–	2.5	–	MHz
		$f_{SC} = 4.4$ MHz	–	3.1	–	MHz
		SECAM	–	3.0	–	MHz
SUPP	subcarrier suppression		26	–	–	dB
CHROMINANCE BANDPASS						
f_{res}	resonant frequency	$f_{SC} = 3.6$ MHz	–	3.58	–	MHz
		$f_{SC} = 4.4$ MHz	–	4.43	–	MHz
B	bandwidth at –3 dB	$f_{SC} = 3.6$ MHz	–	1.4	–	MHz
		$f_{SC} = 4.4$ MHz	–	1.7	–	MHz
CLOCHE FILTER						
f_{res}	resonant frequency	SECAM	4.26	4.29	4.31	MHz
B	bandwidth at –3 dB	SECAM	241	268	295	kHz
Sync input						
VIDEO INPUT						
V_{26}	sync pulse amplitude	Y/CVBS input	50	300	600	mV
	slicing level		–	50	–	%

PAL/NTSC/SECAM decoder/sync processor

TDA9141

SYMBOL	PARAMETER	CONDITIONS	MIN.	TYP.	MAX.	UNIT
t_d	delay of sync pulse due to internal filter		0.2	0.3	0.4	μs
S/N	noise detector threshold level		–	20	–	dB
H	hysteresis		–	3	–	dB
t_d	delay between video signal and internally separated vertical sync pulse		12	18.5	27	μs
Horizontal section						
CLP OUTPUT (OPB/CLP MODE); H_A OUTPUT (LLC/HA MODE)						
V_{OH}	HIGH level output voltage		4.0	5.0	5.5	V
V_{OL}	LOW level output voltage	$I_{\text{sink}} = 2 \text{ mA}$	–	0.2	0.4	V
I_{sink}	sink current		2	–	–	mA
I_{source}	source current		2	–	–	mA
t_W	H_A pulse width (32 LLC pulses)		–	4.7	–	μs
t_d	delay between middle of horizontal sync pulse and middle of H_A	note 2	0.3	0.45	0.6	μs
t_d	delay between negative edge LLC pulse and positive edge H_A pulse	$C_L = 15 \text{ pF}$	10	20	40	ns
t_W	CLP pulse width	21 LLC pulses	–	3.1	–	μs
t_d	delay between middle of horizontal sync pulse and start of CLP pulse	note 2	3.5	3.7	3.9	μs
FIRST LOOP						
Δf	frequency deviation when not locked		–	–	1.5	%
SVRR	supply voltage ripple rejection		–	tbf	–	V
TC	temperature coefficient		–	tbf	–	Hz/°C
f_{CR}	catching range		± 625	–	–	Hz
f_{HR}	holding range		–	–	± 1.4	kHz
ϕ	static phase shift		–	–	0.1	$\mu\text{s}/\text{kHz}$
LLC OUTPUT (LLC/ H_A MODE)						
f_O	output frequency 432 f_H 432 f_H	50 Hz standard 60 Hz standard	–	6.75 6.80	–	MHz MHz
$V_{O(p-p)}$	output amplitude (peak-to-peak value)	$C_L = 15 \text{ pF}$	0.25	–	–	V
V_O	DC output voltage level		–	2.5	–	V
Vertical section						
VERTICAL OSCILLATOR						
f_{fr}	free running frequency	FORF = 1; divider ratio 628 FORF = 0; divider ratio 528	–	50 60	–	Hz Hz
f_{LR}	frequency locking range		43	–	64	Hz

PAL/NTSC/SECAM decoder/sync processor

TDA9141

SYMBOL	PARAMETER	CONDITIONS	MIN.	TYP.	MAX.	UNIT
LR	divider locking range		488	625	722	
V_A output						
V _{OH}	HIGH level output voltage		4.0	5.0	5.5	V
V _{OL}	LOW level output voltage		–	0.2	0.4	V
I _{sink}	sink current		2	–	–	mA
I _{source}	source current		2	–	–	mA
t _W	V _A pulse width	50 Hz standard	–	160	–	μs
		60 Hz standard	–	192	–	μs
t _d	delay between start of vertical sync pulse and positive edge of V _A pulse		–	32	–	μs
Z _O	output impedance	STM = 1	3	–	–	MΩ
Sandcastle output (pin 10)						
V ₁₀	zero level output voltage		0	0.5	1.0	V
I _{sink}	sink current		0.5	–	–	mA
HORIZONTAL AND VERTICAL BLANKING						
V _{bl}	blanking voltage level		2.0	2.5	3.0	V
I _{source}	source current		0.5	–	–	mA
I _{ext}	external current required to force the output to the blanking level		1.0	–	3.0	mA
t _W	horizontal blanking pulse width	69 LLC pulses	–	10.2	–	μs
t _d	delay between start of horizontal blanking and start of clamping pulse	45 LLC pulses	–	6.7	–	μs
CLAMPING PULSE						
V _{clamp}	clamping voltage level		4.0	4.5	5.0	V
I _{source}	source current		0.5	–	–	mA
t _W	pulse width	21 LLC pulses	–	3.1	–	μs
t _d	delay between middle sync of input and start of clamping pulse	note 2	3.5	3.7	3.9	μs
Colour matrix						
G _v	gain					
	from R to Y		–	0.43	–	
	from G to Y		–	0.84	–	
	from B to Y		–	0.16	–	
	from R to U _{out}		–	0.43	–	
	from G to U _{out}		–	0.84	–	
	from B to U _{out}		–	1.27	–	
	from R to V _{out}		–	1.00	–	
	from G to V _{out}		–	0.84	–	
	from B to V _{out}		–	0.16	–	

PAL/NTSC/SECAM decoder/sync processor

TDA9141

SYMBOL	PARAMETER	CONDITIONS	MIN.	TYP.	MAX.	UNIT
Output and input/output port						
O PORT (OPB/CLP MODE)						
V _{OH}	HIGH level output voltage		4.0	5.0	5.5	V
V _{OL}	LOW level output voltage		–	0.2	0.4	V
I _{sink}	sink current		100	–	–	μA
I _{source}	source current		100	–	–	μA
I/O PORT (OPB/CLP MODE)						
V _{OH}	HIGH level output voltage		–	–	V _{SUP}	V
V _{OL}	LOW level output voltage		–	0.2	0.4	V
I _{sink}	sink current		2	–	–	mA
V _{IH}	HIGH level input voltage		2.0	–	–	V
V _{IL}	LOW level input voltage		–	–	0.6	V
YUV switches (note 3)						
RGB INPUTS (NOTE 3)						
V _{I(p-p)}	input voltage (peak-to-peak value)	note 4	–	0.7	1.0	V
Z _I	input impedance		3	–	–	MΩ
UV INPUTS (NOTE 3)						
V _{I(p-p)}	U input voltage (peak-to-peak value)	note 3	–	1.33	1.90	V
V _{I(p-p)}	V input voltage (peak-to-peak value)		–	1.05	1.50	V
Z _I	input impedance (both inputs)		3	–	–	MΩ
Y OUTPUT						
V _{O(p-p)}	U output voltage (peak-to-peak value)	note 4; top sync-to-white	–	1.43	–	V
Z _O	output impedance		–	–	250	Ω
V _O	DC output voltage level	top sync	–	2.5	–	V
S/N	signal-to-noise ratio		–	tbf	–	dB
UV OUTPUTS (NOTE 3)						
V _{O(p-p)}	U output voltage (peak-to-peak value)		–	1.33	1.90	V
V _{O(p-p)}	V output voltage (peak-to-peak value)		–	1.05	1.50	V
Z _O	output impedance (both outputs)		–	–	250	Ω
V _O	DC output voltage level		–	2.7	–	V
GENERAL						
V _{diff}	difference between black levels of YUV outputs in RGB mode and YUV mode	sync locked	–	–	10	mV
NL	non-linearity	any input to any output	–	–	5	%
B	bandwidth	any input to any output	–	7	–	MHz

PAL/NTSC/SECAM decoder/sync processor

TDA9141

SYMBOL	PARAMETER	CONDITIONS	MIN.	TYP.	MAX.	UNIT
CT	crosstalk between RGB and UV _{in} signals on UV _{out}	f = 0 to 5 MHz	–	–	–50	dB
FAST SWITCH SELECT INPUT (PIN 18)						
V _{IH}	HIGH level input voltage	RGB switched on	0.9	–	3.0	V
V _{IL}	LOW level input voltage	UV switched on	0	–	0.5	V
G _v	gain from U _{in} to U _{out} from V _{in} to V _{out}		–	1	–	
t _d	switching delay	between pin 18 and YUV	–	–	20	ns
INPUT CLAMP (PIN 17)						
V _{IH}	HIGH level input voltage	clamping	2.4	–	5.5	V
V _{IL}	LOW level input voltage	no clamping	0	–	0.6	V
t _w	clamping pulse width		1.8	3.5	–	μs
V _{os}	clamping offset voltage on UV outputs		–	–	10	mV
Z _I	input impedance	STM = 1	3	–	–	MΩ

Notes to the characteristics

- All oscillator specifications are measured with the Philips crystal series 4322 143/144. If the spurious response of the reference crystal is less than –3 dB with respect to the fundamental frequency for a damping resistance of 1 kΩ, oscillation at the fundamental frequency is guaranteed. The spurious response of the second crystal must be less than –3 dB with respect to the fundamental frequency for a damping resistance of 1.5 kΩ.
The catching and detuning range are measured for nominal crystal parameters. These are:
load resonance frequency f₀ (C_L = 20 pF) = 4.433619 MHz, (second crystal: 3.579545 MHz)
motional capacitance C_M = 20.6 fF, (second crystal: 14.7 fF)
parallel capacitance C₀ = 5.5 pF, (second crystal: 4.5 pF).
The actual load capacitance in the application should be C_L = 18 pF to account for parasitic capacitances on and off chip.
- This delay is caused by the low pass filter at the sync separator input.
- The output signals of the demodulator are called –(R–Y) and –(B–Y). The colour difference input and output signals of the YUV switch are called UV signals. However, these signals do not have the amplitude correction factor of real UV signals. They are called UV signals and not –(R–Y) and –(B–Y) to prevent confusion between the colour difference signals of the demodulator and the colour difference signals of the YUV switch.
- This value refers to signals including a sync pulse. For Y signals composed to the RGB inputs this output voltage is 30% lower, as there is no sync pulse on such signals.

PAL/NTSC/SECAM decoder/sync processor

TDA9141

PACKAGE OUTLINE

SDIP32: plastic shrink dual in-line package; 32 leads (400 mil)

SOT232-1

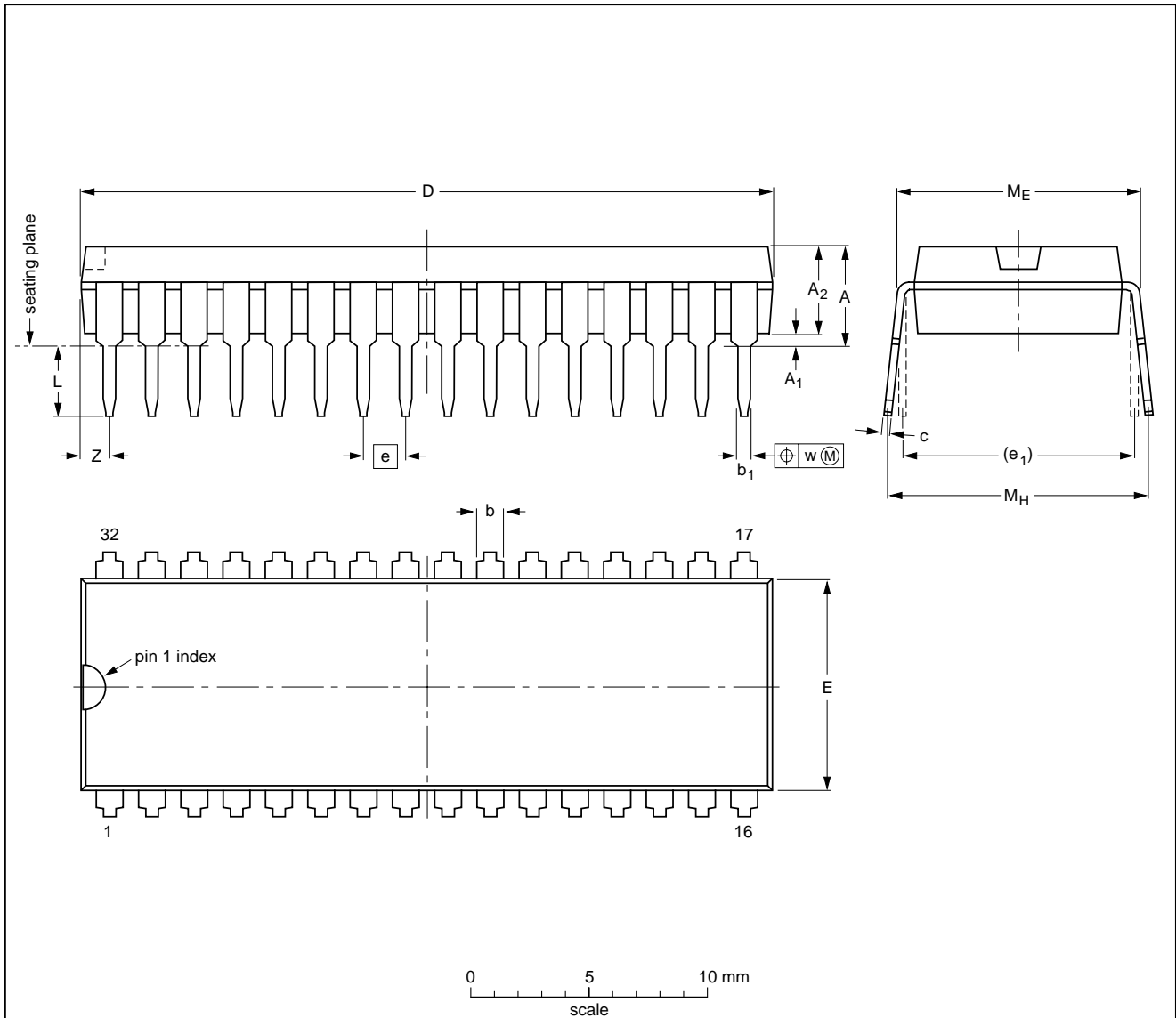

DIMENSIONS (mm are the original dimensions)

UNIT	A max.	A ₁ min.	A ₂ max.	b	b ₁	c	D ⁽¹⁾	E ⁽¹⁾	e	e ₁	L	M _E	M _H	w	Z ⁽¹⁾ max.
mm	4.7	0.51	3.8	1.3 0.8	0.53 0.40	0.32 0.23	29.4 28.5	9.1 8.7	1.778	10.16	3.2 2.8	10.7 10.2	12.2 10.5	0.18	1.6

Note

1. Plastic or metal protrusions of 0.25 mm maximum per side are not included.

OUTLINE VERSION	REFERENCES				EUROPEAN PROJECTION	ISSUE DATE
	IEC	JEDEC	EIAJ			
SOT232-1						92-11-17 95-02-04

PAL/NTSC/SECAM decoder/sync processor

TDA9141

SOLDERING

Introduction

There is no soldering method that is ideal for all IC packages. Wave soldering is often preferred when through-hole and surface mounted components are mixed on one printed-circuit board. However, wave soldering is not always suitable for surface mounted ICs, or for printed-circuits with high population densities. In these situations reflow soldering is often used.

This text gives a very brief insight to a complex technology. A more in-depth account of soldering ICs can be found in our "IC Package Databook" (order code 9398 652 90011).

Soldering by dipping or by wave

The maximum permissible temperature of the solder is 260 °C; solder at this temperature must not be in contact

with the joint for more than 5 seconds. The total contact time of successive solder waves must not exceed 5 seconds.

The device may be mounted up to the seating plane, but the temperature of the plastic body must not exceed the specified maximum storage temperature ($T_{stg\ max}$). If the printed-circuit board has been pre-heated, forced cooling may be necessary immediately after soldering to keep the temperature within the permissible limit.

Repairing soldered joints

Apply a low voltage soldering iron (less than 24 V) to the lead(s) of the package, below the seating plane or not more than 2 mm above it. If the temperature of the soldering iron bit is less than 300 °C it may remain in contact for up to 10 seconds. If the bit temperature is between 300 and 400 °C, contact may be up to 5 seconds.

DEFINITIONS

Data sheet status	
Objective specification	This data sheet contains target or goal specifications for product development.
Preliminary specification	This data sheet contains preliminary data; supplementary data may be published later.
Product specification	This data sheet contains final product specifications.
Limiting values	
Limiting values given are in accordance with the Absolute Maximum Rating System (IEC 134). Stress above one or more of the limiting values may cause permanent damage to the device. These are stress ratings only and operation of the device at these or at any other conditions above those given in the Characteristics sections of the specification is not implied. Exposure to limiting values for extended periods may affect device reliability.	
Application information	
Where application information is given, it is advisory and does not form part of the specification.	

LIFE SUPPORT APPLICATIONS

These products are not designed for use in life support appliances, devices, or systems where malfunction of these products can reasonably be expected to result in personal injury. Philips customers using or selling these products for use in such applications do so at their own risk and agree to fully indemnify Philips for any damages resulting from such improper use or sale.

PURCHASE OF PHILIPS I²C COMPONENTS



Purchase of Philips I²C components conveys a license under the Philips' I²C patent to use the components in the I²C system provided the system conforms to the I²C specification defined by Philips. This specification can be ordered using the code 9398 393 40011.