

# DATA SHEET

## **TDA8798**

**Dual 8-bit, 100 Msps A/D converter  
with DPGA**

Objective specification  
Supersedes data of 1998 Apr 15  
File under Integrated Circuits, IC02

1999 Sep 16

## Dual 8-bit, 100 Msps A/D converter with DPGA

## TDA8798

### FEATURES

- Dual 8-bit Analog-to-Digital Converter (ADC)
- Sampling rate up to 100 million samples per second (Msps)
- Dual 34 dBV 6-bit Digitally Programmable Gain Amplifier (DPGA) with optional power-off
- Optional external equalization filter with capacitive coupling between DPGA and ADC
- Serial Interface (SI) for DPGA gain control using either parallel load mode or count-up/count-down mode
- 3.3 V TTL/CMOS compatible I/O
- Differential or single-ended TTL/CMOS clock interface
- AC or DC coupling for DPGA inputs.

### APPLICATIONS

- High-dynamic range acquisition front-ends
- Digital data storage read channels.

### GENERAL DESCRIPTION

The TDA8798 is a dual 8-bit ADC with DPGA. The 100 Msps maximum sampling rate and 34 dBV DPGA gain range optimizes the ADC for high dynamic range applications.

### QUICK REFERENCE DATA

SYMBOL	PARAMETER	CONDITIONS	MIN.	TYP.	MAX.	UNIT
$V_{DDA}$	analog supply voltage		3.15	3.3	3.45	V
$V_{DDD}$	digital supply voltage		3.0	3.3	3.6	V
$V_{DDO}$	output stage supply voltage		2.7	3.3	3.6	V
$I_{DDA}$	analog supply current	with DPGAEN LOW	–	106	–	mA
		with DPGAEN HIGH	–	tbf	–	mA
$I_{DDD}$	digital supply current		–	30	–	mA
$I_{DDO}$	output stage supply current		–	3	–	mA
INL	DC integral non-linearity	from IC analog input to digital output; ramp input; $f_{CLK} = 100$ MHz with DPGA at $G_{(min)}$	–	$\pm 3.0$	tbf	LSB
		without DPGA	–	$\pm 1.0$	tbf	LSB
DNL	DC differential non-linearity	from IC analog input to digital output; ramp input; $f_{CLK} = 100$ MHz with DPGA at $G_{(min)}$	–	$\pm 0.5$	tbf	LSB
		without DPGA	–	$\pm 0.5$	tbf	LSB
$V_{n(o)(rms)}$	output referred noise (RMS value)	DPGA at $G_{(max)}$ ; $Z_i = 50 \Omega$ ; noise bandwidth = 15 MHz	–	tbf	2	$mV_{rms}$
$B_{(-3dB)(ADC)}$	ADC –3 dB analogue bandwidth	at $V_{i(dif)(FS)}$	–	120	–	MHz
$B_{(-3dB)(DPGA)}$	DPGA –3 dB bandwidth	at $V_{i(dif)(max)}$	30	tbf	–	MHz
$f_{(sample)(max)}$	maximum sampling rate		100	–	–	Msps
$P_{tot}$	total power dissipation	with DPGAEN LOW	–	460	500	mW
		with DPGAEN HIGH	–	tbf	tbf	mW

# Dual 8-bit, 100 Msps A/D converter with DPGA

TDA8798

## ORDERING INFORMATION

TYPE NUMBER	PACKAGE		
	NAME	DESCRIPTION	VERSION
TDA8798HL	LQFP64	plastic low profile quad flat package; 64 leads; body 10 × 10 × 1.4 mm	SOT314-2

## BLOCK DIAGRAM

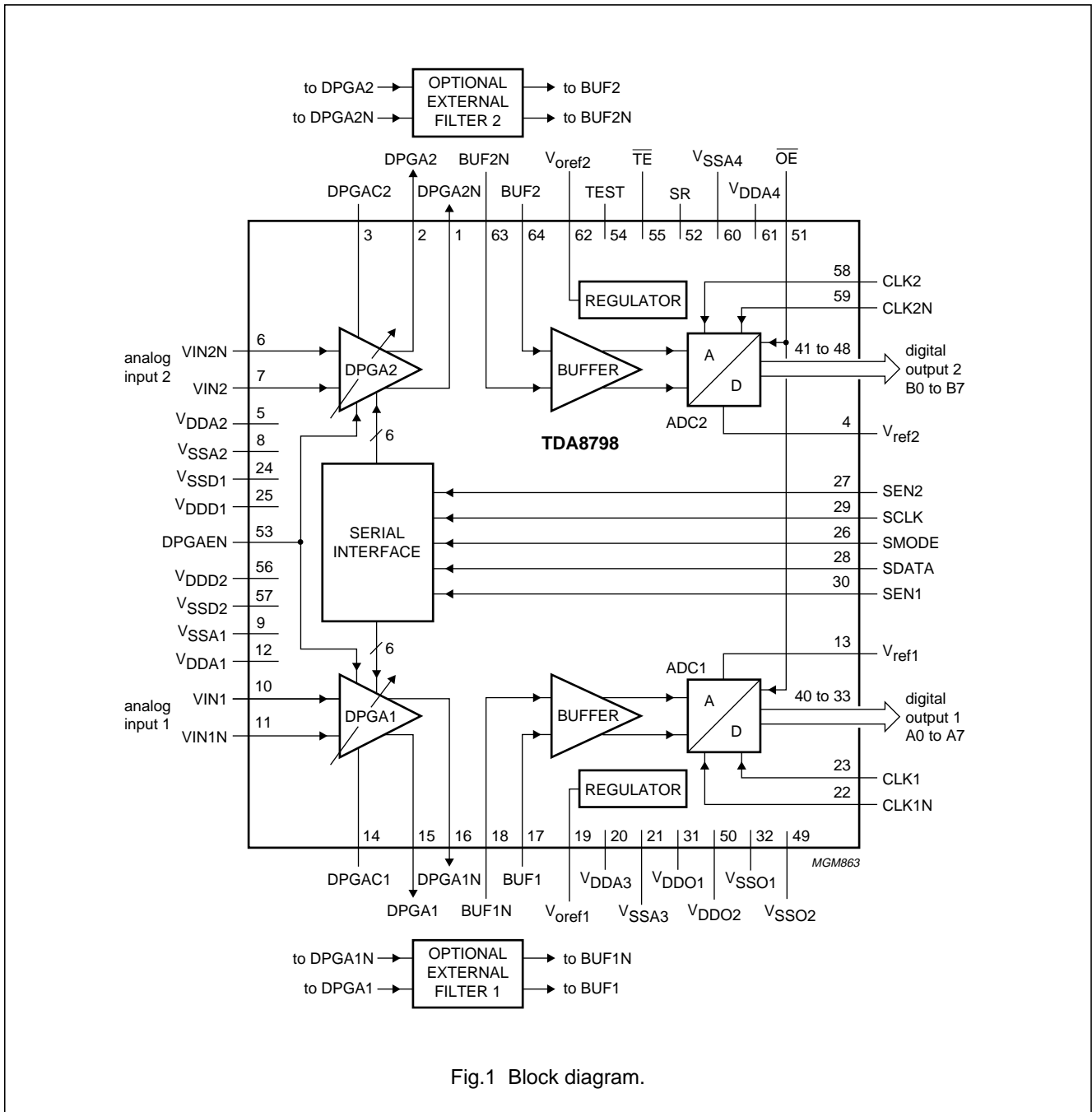
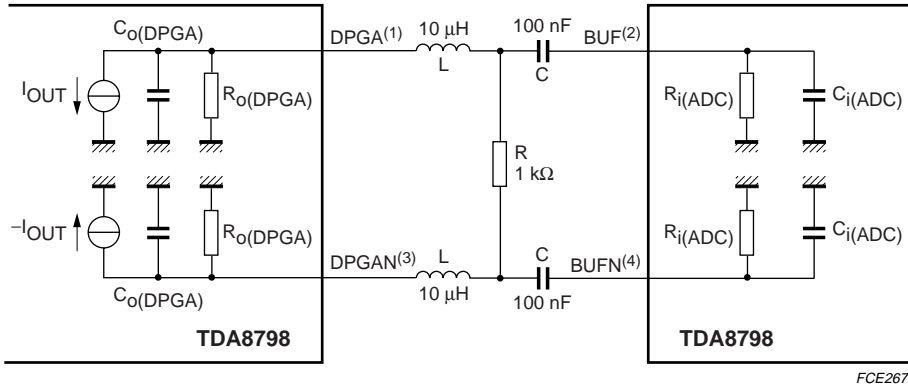

Fig.1 Block diagram.

Dual 8-bit, 100 Msps A/D converter with DPGA

TDA8798



FCE267

External filtering may be used between DPGA and ADC to limit the noise bandwidth.

The external filter has a low-pass cut-off frequency of  $f_{l(-3dB)} \approx \frac{1}{2\pi} \times \frac{R/2 + R_o(DPGA)}{L}$ .

and a high-pass cut-off frequency of  $f_{h(-3dB)} \approx \frac{1}{2\pi} \times \frac{1}{R_i(ADC) \times C}$ .

Other types of filter may be used if DC biasing is correct.

- (1) DPGA1/DPGA2
- (2) BUF1/BUF2
- (3) DPGA1N/DPGA2N
- (4) BUF1N/BUF2N

Fig.2 External filter.

PINNING

SYMBOL	PIN	DESCRIPTION
DPGA2N	1	DPGA2 inverting output
DPGA2	2	DPGA2 non-inverting output
DPGAC2	3	DPGA2 bandwidth limitation control
V <sub>ref2</sub>	4	ADC2 reference output
V <sub>DDA2</sub>	5	DPGA2 analog supply voltage
VIN2N	6	DPGA2 inverting input voltage
VIN2	7	DPGA2 non-inverting input voltage
V <sub>SSA2</sub>	8	DPGA2 analog ground
V <sub>SSA1</sub>	9	DPGA1 analog ground
VIN1	10	DPGA1 non-inverting input voltage
VIN1N	11	DPGA1 inverting input voltage
V <sub>DDA1</sub>	12	DPGA1 analog supply voltage
V <sub>ref1</sub>	13	ADC1 reference output
DPGAC1	14	DPGA1 bandwidth limitation control
DPGA1	15	DPGA1 non-inverting output
DPGA1N	16	DPGA1 inverting output

Dual 8-bit, 100 Msps A/D converter with  
DPGA

TDA8798

SYMBOL	PIN	DESCRIPTION
BUF1	17	buffer1 non-inverting input
BUF1N	18	buffer1 inverting input
V <sub>oref1</sub>	19	buffer1 common mode reference output
V <sub>DDA3</sub>	20	ADC1 analog supply voltage 3
V <sub>SSA3</sub>	21	ADC1 analog ground 3
CLK1N	22	ADC1 inverting clock input
CLK1	23	ADC1 non-inverting clock input
V <sub>SSD1</sub>	24	digital ground 1
V <sub>DD1</sub>	25	digital supply voltage 1
SMODE	26	serial interface mode input
SEN2	27	serial interface enable 2 (active low)
SDATA	28	serial interface data input
SCLK	29	serial interface clock input
SEN1	30	serial interface enable 1 (active low)
V <sub>DDO1</sub>	31	output stage supply voltage 1
V <sub>SSO1</sub>	32	output stage ground 1
A7	33	channel 1 output bit 7 (MSB)
A6	34	channel 1 output bit 6
A5	35	channel 1 output bit 5
A4	36	channel 1 output bit 4
A3	37	channel 1 output bit 3
A2	38	channel 1 output bit 2
A1	39	channel 1 output bit 1
A0	40	channel 1 output bit 0 (LSB)
B0	41	channel 2 output bit 0 (LSB)
B1	42	channel 2 output bit 1
B2	43	channel 2 output bit 2
B3	44	channel 2 output bit 3
B4	45	channel 2 output bit 4
B5	46	channel 2 output bit 5
B6	47	channel 2 output bit 6
B7	48	channel 2 output bit 7 (MSB)
V <sub>SSO2</sub>	49	output stage ground 2
V <sub>DDO2</sub>	50	output stage supply voltage 2
$\overline{OE}$	51	digital output enable (active LOW)
SR	52	digital output bit slew-rate control
DPGAEN	53	DPGA enable (active LOW)
TEST	54	test input (to be grounded)
$\overline{TE}$	55	track-and-hold enable (active LOW)
V <sub>DD2</sub>	56	digital supply voltage 2
V <sub>SS2</sub>	57	digital ground 2

Dual 8-bit, 100 Msps A/D converter with DPGA

TDA8798

SYMBOL	PIN	DESCRIPTION
CLK2	58	ADC2 non-inverting clock input
CLK2N	59	ADC2 inverting clock input
V <sub>SSA4</sub>	60	ADC2 analog ground 4
V <sub>DDA4</sub>	61	ADC2 analog supply voltage 4
V <sub>oref2</sub>	62	buffer2 common mode reference output
BUF2N	63	buffer2 inverting input
BUF2	64	buffer2 non-inverting input

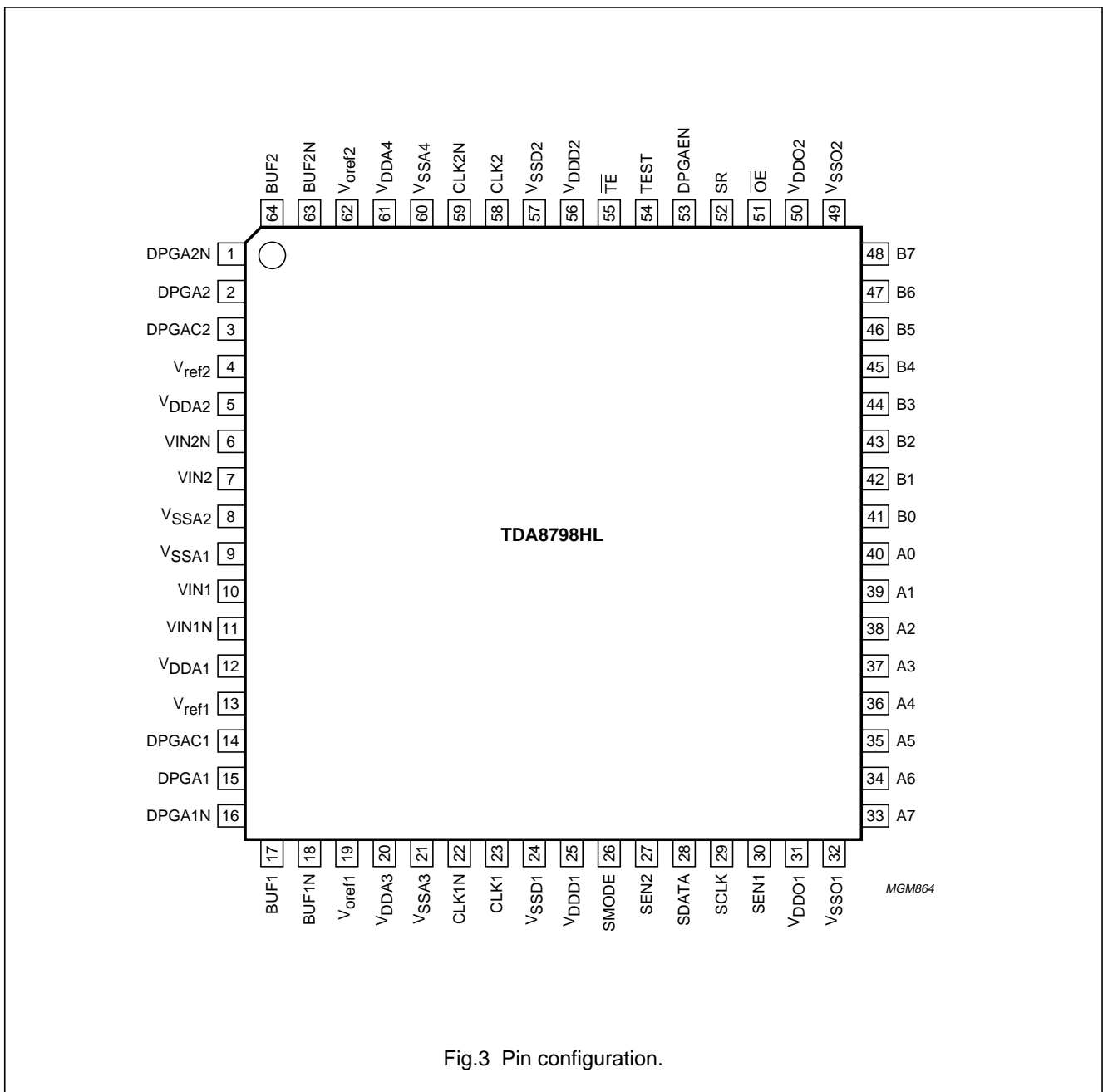

Fig.3 Pin configuration.

## Dual 8-bit, 100 Msps A/D converter with DPGA

TDA8798

### FUNCTIONAL DESCRIPTION

The TDA8798 comprises two independent fully differential signal chains each having a DPGA and a high-speed ADC. A serial interface allows the gain of each DPGA to be controlled independently. To improve signal conditions, an AC-coupled external filter can be connected between a DPGA and ADC. The TDA8798 can be used as a dual 8-bit ADC without DPGA functionality, using less power.

#### Digitally Programmable Gain Amplifier (DPGA)

The gain of the differential DPGA is programmable from 0 to 34 dBV in 63 equal steps by a 6-bit word output in parallel from a gain control register in the SI. For all gain settings, the DPGA signal bandwidth exceeds 30 MHz. The settling time between gain changes can be adjusted by an external decoupling capacitor connected to DPGAC1 (pin 14) and/or DPGAC2 (pin 3). The analog input signals can be either AC or DC coupled. When used only as a dual 8-bit ADC, both DPGAs can be disabled to reduce power consumption.

#### Analog-to-Digital Converter (ADC)

The 8-bit ADC converts the differential analog input signal into a binary output format at a maximum conversion rate of 100 Msps. All digital input and output signals are TTL/CMOS compatible.

The ADC clock signal can be from either a differential or a single-ended source; when single-ended, the unused clock input pin should be decoupled externally. The analog input to the ADC is AC coupled.

When used only as a dual ADC, the ADC can be externally biased by regulator output  $V_{\text{oref1}}$  (pin 19) and/or  $V_{\text{oref2}}$  (pin 62) using series resistors of, for example, 50  $\Omega$ , connected to the ADC buffer inputs providing a lower input impedance. This requires  $V_{\text{oref1}}$  and/or  $V_{\text{oref2}}$  to be decoupled to ground by a 10 nF capacitor.

$V_{\text{ref1}}$  (pin 13) and/or  $V_{\text{ref2}}$  (pin 4) provide a voltage corresponding to the bias of the ADC which can be used as a reference output to an external control circuit. Alternatively, an external control voltage can be applied to these pins to adjust the full-scale range of the ADC.

### Serial Interface (SI)

The SI allows the gain of each DPGA to be controlled independently using either a parallel load mode or a count-up/count-down mode. The gain control mode is selected by the state of SMODE. The operation of DPGA gain control is shown in Timing diagram, (see Fig.4).

#### Parallel load mode

This mode loads gain control data serially into a decoder in the SI. Each of the six bits are loaded on the rising edge of SCLK. After the load has completed, SEN goes inactive, loading the data in parallel to a gain control register in the SI, changing the gain of the DPGA.

#### Count-up/count-down mode

Count-up/count-down mode is selected when SMODE is in the opposite state to parallel load mode. This mode either increments or decrements the SI gain control register in one-bit steps when SEN and SCLK are both active; the state of SDATA determines the count direction (up or down). This allows the gain of the DPGA to be changed asynchronously and intermittently.

#### ADC digital outputs

Digital noise on the internal supply lines increases when the  $V_{\text{DDO}}$  voltage increases, affecting the crosstalk between channels. This effect can be reduced by making SR (pin 52) HIGH, changing the slew-rate of the ADC digital outputs.

Dual 8-bit, 100 Msps A/D converter with DPGA

TDA8798

**Table 1** Serial interface truth table; see notes 1 and 2

SMODE	SCLK	SEN1	SEN2	SDATA	ACTION
0	X, $\bar{\downarrow}$	1	1	U	WAIT
0	$\uparrow$	1	1	Di	SISR: SISR $\leftarrow$ Di
0	$\uparrow$	0	1	1	SISR: SISR $\leftarrow$ 1 GCR1: GCR1 + 1
0	$\uparrow$	0	1	0	SISR: SISR $\leftarrow$ 0 GCR1: GCR1 - 1
0	$\uparrow$	1	0	1	SISR: SISR $\leftarrow$ 1 GCR2: GCR2 + 1
0	$\uparrow$	1	0	0	SISR: SISR $\leftarrow$ 0 GCR2: GCR2 - 1
0	$\uparrow$	0	0	1	SISR: SISR $\leftarrow$ 1 GCR1: GCR1 + 1 GCR2: GCR2 + 1
0	$\uparrow$	0	0	0	SISR: SISR $\leftarrow$ 0 GCR1: GCR1 - 1 GCR2: GCR2 - 1
1	X, $\bar{\downarrow}$	X, $\bar{\downarrow}$	X, $\bar{\downarrow}$	U	WAIT
1	$\uparrow$	X, $\bar{\downarrow}$	X, $\bar{\downarrow}$	Di	SISR: SISR $\leftarrow$ Di
1	X, $\bar{\downarrow}$	$\uparrow$	X, $\bar{\downarrow}$	U	GCR1: SISR
1	X, $\bar{\downarrow}$	X, $\bar{\downarrow}$	$\uparrow$	U	GCR2: SISR
1	X, $\bar{\downarrow}$	$\uparrow$	$\uparrow$	U	GCR1: SISR GCR2: SISR

**Notes**



1. ' $\leftarrow$  Di': shifting LSB and loading new LSB with value Di.
2. In count-up/count-down mode, the gain control register cannot be incremented above the maximum gain value of 63, or decremented below the minimum gain value of 0.



Dual 8-bit, 100 Msps A/D converter with  
DPGA

TDA8798

**Table 2** Abbreviations

SYMBOL	DESCRIPTION
GCR1	DPGA1 gain control register value
GCR2	DPGA2 gain control register value
SISR	Serial interface shift register value
X	can be either logic state 0 or logic state 1
	rising edge
	falling edge
U	can be either undefined logic state X rising edge or falling edge
Di	Data input

**Table 3**  $\overline{TE}$  truth table

$\overline{TE}$	ADC TRACK-AND-HOLD
0	track-and-hold enabled
1	track enabled

**Table 4** SR truth table

SR	ADC DIGITAL OUTPUT SLEW RATE
0	maximum
1	minimum

**Table 5** DPGAEN truth table

DPGAEN	DPGA FUNCTIONALITY
0	enabled
1	disabled

**Table 6** Gain Control

GAIN CONTROL REGISTER VALUE	GAIN (dBV)
000000	0.00
000001	0.54
000010	1.08
...	...
...	...
...	...
111110	33.46
111111	34.00

**LIMITING VALUES**

In accordance with the Absolute Maximum Rating System (IEC 134).

SYMBOL	PARAMETER	CONDITIONS	MIN.	MAX.	UNIT
$V_{DDA}$	analog supply voltage		-0.3	+7.0	V
$V_{DDD}$	digital supply voltage		-0.3	+7.0	V
$V_{DDO}$	output stage supply voltage		-0.3	+7.0	V
$\Delta V_{DDX}$	supply voltage differences between $V_{DDA}$ and $V_{DDD}$ $V_{DDO}$ and $V_{DDD}$ $V_{DDA}$ and $V_{DDO}$		-1.0	+1.0	V
$V_{i(VIN)}$	input voltage range on VIN1 and VIN2 (pins 10 and 7)	referenced to $V_{SSA}$	-0.3	+7.0	V
$I_o$	output current		-	10	mA
$T_{stg}$	storage temperature		-55	+150	°C
$T_{amb}$	ambient temperature		0	70	°C
$T_j$	junction temperature		-	104	°C

# Dual 8-bit, 100 Msps A/D converter with DPGA

TDA8798

## HANDLING

Inputs and outputs are protected against electrostatic discharges in normal handling. However, to be totally safe, it is desirable to take normal precautions appropriate to handling integrated circuits.

## THERMAL CHARACTERISTICS

SYMBOL	PARAMETER	CONDITIONS	VALUE	UNIT
$R_{th(j-a)}$	thermal resistance from junction to ambient	in free air	68	K/W

## CHARACTERISTICS

$V_{DDA} = V_5$  (or  $V_{12}$  or  $V_{20}$  or  $V_{61}$ ) to  $V_8$  (or  $V_9$  or  $V_{21}$  or  $V_{60}$ ) = 3.15 to 3.45 V;  $V_{DDD} = V_{25}$  (or  $V_{56}$ ) to  $V_{24}$  (or  $V_{57}$ ) = 3.0 to 3.6 V;  $V_{DDO} = V_{31}$  (or  $V_{50}$ ) to  $V_{32}$  (or  $V_{49}$ ) = 2.7 to 3.6 V;  $V_{SSA}$ ,  $V_{SSD}$  and  $V_{SSO}$  shorted together;  $V_{DDA}$  to  $V_{DDD} = -0.25$  to  $+0.25$  V;  $V_{DDD}$  to  $V_{DDO} = -0.25$  to  $+0.90$  V;  $V_{DDA}$  to  $V_{DDO} = -0.25$  to  $+0.75$  V;  $T_{amb} = 0$  to  $70$  °C; typical values measured at  $V_{DDA} = V_{DDD} = V_{DDO} = 3.3$  V and  $T_{amb} = 25$  °C; unless otherwise specified.

SYMBOL	PARAMETER	CONDITIONS	MIN.	TYP.	MAX.	UNIT
<b>Supplies</b>						
$V_{DDA}$	analog supply voltage		3.15	3.3	3.45	V
$V_{DDD}$	digital supply voltage		3.0	3.3	3.6	V
$V_{DDO}$	output stage supply voltage		2.7	3.3	3.6	V
$I_{DDA}$	analog supply current	DPGAEN LOW	–	106	–	mA
		DPGAEN HIGH	–	tbf	–	mA
$I_{DDD}$	digital supply current		–	30	–	mA
$I_{DDO}$	output stage supply current	$f_{CLK} = 100$ MHz; ramp input	–	3	–	mA
<b>Digital programmable gain amplifiers</b>						
ANALOG INPUTS (VIN1, VIN1N, VIN2 AND VIN2N)						
$V_{i(dif)(max)(p-p)}$	maximum differential input voltage (peak-to-peak value)	at $G_{(min)}$	–	0.5	–	V
		at $G_{(max)}$	–	10	–	mV
$V_{i(cm)(DPGA)}$	common mode input voltage		tbf	2.8	tbf	V
$I_{i(DPGA)}$	input current	at $V_{i(cm)(DPGA)}$	–	tbf	–	μA
$R_{i(DPGA)}$	input resistance		1	–	–	kΩ
$C_{i(DPGA)}$	input capacitance		–	–	5	pF
ANALOG OUTPUTS (DPGA1, DPGA1N, DPGA2 AND DPGA2N)						
$V_{o(dif)(max)(p-p)}$	maximum differential output voltage (peak-to-peak value)	at $G_{(min)}$	–	0.5	–	V
		at $G_{(max)}$	–	0.5	–	V
$V_{o(cm)(DPGA)}$	common mode output voltage		–	3.1	–	V
$R_{o(DPGA)}$	output resistance	at $V_{o(cm)(DPGA)}$	–	115	160	Ω
$C_{o(DPGA)}$	output capacitance		–	–	5	pF

Dual 8-bit, 100 Msps A/D converter with  
DPGA

TDA8798

SYMBOL	PARAMETER	CONDITIONS	MIN.	TYP.	MAX.	UNIT
<b>BANDWIDTH AND SETTLING</b>						
$B_{(-3dB)(DPGA)}$	DPGA -3 dB bandwidth	at $V_{i(dif)(max)}$	30	tbf	–	MHz
$t_{st}$	settling time	full-scale transition 10% to 90%	40	–	–	ns
$t_{d(g)}$	group delay	$f_i$ up to 15 MHz				
		at $G_{(min)}$	–	tbf	–	ps
		at $G_{(max)}$	–	tbf	–	ps
<b>GAIN</b>						
$G_{(min)}$	minimum gain setting		tbf	0	tbf	dBV
$G_{(max)}$	maximum gain setting		tbf	34	tbf	dBV
$G_{step}$	gain step size		–	0.54	–	dBV
$G_{step(L)}$	gain step size linearity (actual gain step/average – 1)		–0.75	–	+0.75	dBV
$G_{(m)(c-c)}$	channel-to-channel gain matching	at $G_{(min)}$	–	tbf	–	dB
		at $G_{(max)}$	–	tbf	–	dB
$\Delta G/\Delta T$	amplifier gain stability as a function of temperature	at $G_{(min)}$	–	8	tbf	mdB/°C
		at $G_{(max)}$	–	8	tbf	mdB/°C
$\Delta G/\Delta V_{DD}$	amplifier gain stability as a function of power supply voltage	at $G_{(min)}$	–	0.4	tbf	dB/V
		at $G_{(max)}$	–	0.8	tbf	dB/V
<b>GAIN SWITCHING; <math>T_{AMB} = 25\text{ °C}</math></b>						
$t_{st(G-G)}$	settling time between two consecutive gain settings	$C_L = 68\text{ pF}$	–	160	–	ns
$t_{PD}$	propagation delay		–	–	20	ns
<b>REJECTION</b>						
PSRR	power supply rejection ratio	DC to 15 MHz	40	–	–	dB
CMRR	common mode rejection ratio	at $G_{(min)}$	40	–	–	dB
<b>HARMONICS; <math>T_{AMB} = 25\text{ °C}</math></b>						
HD2	second harmonic distortion	$f_i = 15\text{ MHz};$ at $V_{o(dif)(max)}$ ; at gain control register:				
		00H	40	tbf	–	dB
		20H	40	tbf	–	dB
		3FH	–	tbf	–	dB
HD3	third harmonic distortion	$f_i = 15\text{ MHz};$ at $V_{o(dif)(max)}$ ; at gain control register:				
		00H	tbf	50	–	dB
		20H	tbf	50	–	dB
		3FH	–	50	–	dB

Dual 8-bit, 100 Msps A/D converter with  
DPGA

TDA8798

SYMBOL	PARAMETER	CONDITIONS	MIN.	TYP.	MAX.	UNIT
<b>NOISE</b>						
$V_{n(o)(rms)}$	output referred noise (RMS value)	DPGA at $G_{(max)}$ ; $Z_i = 50 \Omega$ ; noise bandwidth = 15 MHz	–	tbf	2	$mV_{rms}$
<b>ADC (without DPGA; <math>f_{CLK} = 100</math> MHz; from buffer input to digital output)</b>						
<b>ANALOG INPUTS (BUF1, BUF1N, BUF2 AND BUF2N)</b>						
$V_{i(dif)(FS)(p-p)}$	differential input voltage full-scale amplitude; (peak-to-peak value)		–	500	–	mV
$V_{i(cm)(ADC)}$	common mode input voltage		–	tbf	–	V
$I_{i(ADC)}$	input current	at $V_{i(cm)(ADC)}$	–	tbf	–	$\mu A$
$R_{i(ADC)}$	input resistance		–	20	–	$k\Omega$
$C_{i(ADC)}$	input capacitance		–	3	–	pF
<b>STATIC LINEARITY</b>						
$NL_{dc(i)}$	DC integral non-linearity	ramp input; without DPGA with DPGA at $G_{(min)}$	– –	$\pm 1.0$ $\pm 3.0$	tbf tbf	LSB LSB
$NL_{dc(dif)}$	DC differential non-linearity	ramp input; without DPGA with DPGA at $G_{(min)}$	– –	$\pm 0.5$ $\pm 0.5$	tbf tbf	LSB LSB
<b>DYNAMIC PERFORMANCE</b>						
THD	total harmonic distortion	$f_i = 4.43$ MHz	–	–55	–	dB
S/N	signal-to-noise ratio	without harmonics	–	–46	–	dB
<b>BANDWIDTH</b>						
$B_{(-3dB)(ADC)}$	ADC –3 dB analog bandwidth		–	120	–	MHz
<b>CROSSTALK BETWEEN ADC1 AND ADC2</b>						
$\alpha_{ct}$	crosstalk between channels		–	–40	–	dB
<b>CLOCK INPUTS: CLK1, CLK1N, CLK2 AND CLK2N; note 1</b>						
$V_{IL}$	LOW-level clock input voltage		–	–	0.8	V
$V_{IH}$	HIGH-level clock input voltage		2.0	–	$V_{DDD}$	V
$I_{IH}$	HIGH-level clock input current		–	–	100	$\mu A$
$I_{IL}$	LOW-level clock input current		–100	–	–	$\mu A$
<b>DIGITAL CONTROL INPUTS (<math>\overline{OE}</math>, <math>\overline{TE}</math>, TEST, DPGAEN AND SR)</b>						
$V_{IL}$	LOW-level input voltage		–	–	0.8	V
$V_{IH}$	HIGH-level input voltage		2.0	–	$V_{DDD}$	V
$I_{IH}$	HIGH-level input current		–5	–	+5	$\mu A$
$I_{IL}$	LOW-level input current		–5	–	+5	$\mu A$

Dual 8-bit, 100 Msps A/D converter with  
DPGA

TDA8798

SYMBOL	PARAMETER	CONDITIONS	MIN.	TYP.	MAX.	UNIT
DIGITAL OUTPUTS (A0 TO A7 AND B0 TO B7)						
$V_{OL}$	LOW-level output voltage	$I_O = 1 \text{ mA}$	–	–	0.4	V
$V_{OH}$	HIGH-level output voltage	$I_O = -1 \text{ mA}$	$V_{DDO} - 0.4 \text{ V}$	–	–	V
$I_{OZ}$	output current in 3-state mode	$V_O > 0.4 \text{ V};$ $V_O < (V_{DDO} - 0.4 \text{ V})$	-20	–	+20	$\mu\text{A}$
ADC CLOCK TIMING						
$f_{CLK(max)}$	maximum clock frequency		100	–	–	MHz
$t_{W(CLKL)}$	clock pulse width LOW duration		4.0	–	–	ns
$t_{W(CLKH)}$	clock pulse width HIGH duration		4.0	–	–	ns
$t_{r(CLK)}$	clock pulse rise time		0.75	1	2	ns
$t_{f(CLK)}$	clock pulse fall time		0.75	1	2	ns
DATA TIMING (see Fig.4); $F_{CLK} = 100 \text{ MHz}; C_{DPGAC} = 10 \text{ pF}$						
$t_{d(s)(D)}$	data sampling delay time		–	–	tbf	ns
$t_{d(Q)}$	data output delay time	SR HIGH	–	5.0	tbf	ns
		SR LOW	–	tbf	tbf	ns
$t_{h(Q)}$	data output hold time	SR HIGH	tbf	5.0	–	ns
		SR LOW	tbf	tbf	–	ns
3-STATE OUTPUT DELAY TIMES (see Fig.6)						
$t_{dZH}$	output delay enable at logic HIGH	SR HIGH	–	tbf	tbf	ns
		SR LOW	–	tbf	tbf	ns
$t_{dZL}$	output delay enable at logic LOW	SR HIGH	–	tbf	tbf	ns
		SR LOW	–	tbf	tbf	ns
$t_{dHZ}$	output delay disable at logic HIGH	SR HIGH	–	tbf	tbf	ns
		SR LOW	–	tbf	tbf	ns
$t_{dLZ}$	output delay disable at logic LOW	SR HIGH	–	tbf	tbf	ns
		SR LOW	–	tbf	tbf	ns
ADC REFERENCE OUTPUTS ( $V_{REF1}$ AND $V_{REF2}$ )						
$V_{O(ref)}$	ADC reference output voltage		–	1.24	–	V
$R_{O(ref)}$	ADC reference output resistance	at $V_{O(ref)}$	–	–	10	$\Omega$
$I_{O(ref)(max)}$	ADC reference maximum output current		–	4.0	–	mA
$C_{O(ref)}$	ADC reference output capacitance		–	–	3	pF

Dual 8-bit, 100 Msps A/D converter with  
DPGA

TDA8798

SYMBOL	PARAMETER	CONDITIONS	MIN.	TYP.	MAX.	UNIT
COMMON MODE REFERENCE OUTPUTS ( $V_{OREF1}$ AND $V_{OREF2}$ )						
$V_{o(ref)}$	reference output voltage		–	$V_{DDA} - 0.42$ V	–	V
$R_{o(ref)}$	reference output resistance	at $V_{o(cm)(ref)}$	–	400	–	$\Omega$
$I_{o(ref)}$	reference maximum output current	at $V_{o(cm)(ref)} - 0.2$ V	–	170	–	$\mu$ A
$C_{o(ref)}$	reference output capacitance		–	–	3	pF
<b>Serial Interface</b>						
DIGITAL INPUTS (SEN1, SEN2, SCLK, SDATA AND SMODE)						
$V_{IL}$	LOW-level input voltage		0	–	0.8	V
$V_{IH}$	HIGH-level input voltage		2.0	–	$V_{DDD}$	V
$I_{IH}$	HIGH-level input current		–5	0	+5	$\mu$ A
$I_{IL}$	LOW-level input current		–5	0	+5	$\mu$ A
GAIN CONTROL DATA TIMING (see Fig.4)						
$f_{SCLK(max)}$	maximum clock frequency		5	–	–	MHz
$t_{W(SCLKH)}$	clock pulse width HIGH		20	–	–	ns
$t_{W(SCLKL)}$	clock pulse width LOW		20	–	–	ns
$t_{su(SEN-SCLK)}$	SEN to SCLK set-up time		5	–	–	ns
$t_{h(SEN-SCLK)}$	SEN to SCLK hold time		5	–	–	ns
$t_{su(SDATA-SCLK)}$	SDATA to SCLK set-up time		5	–	–	ns
$t_{h(SMODE-SCLK)}$	SMODE to SCLK hold time		5	–	–	ns
$t_{h(SMODE-SEN)}$	SMODE to SEN hold time		5	–	–	ns
$t_{d(SEN-Q)}$	delay SEN rising edge to change gain control register value		–	–	5	ns
$t_{d(SCLK-Q)}$	delay SCLK rising edge to change gain control register value		–	–	5	ns

**Note**

1. Single-ended clock signal sources are allowed. The unused clock input is internally biased at the logical threshold (1.65 V for nominal supply conditions), and should be correctly decoupled.

Dual 8-bit, 100 Msps A/D converter with DPGA

TDA8798

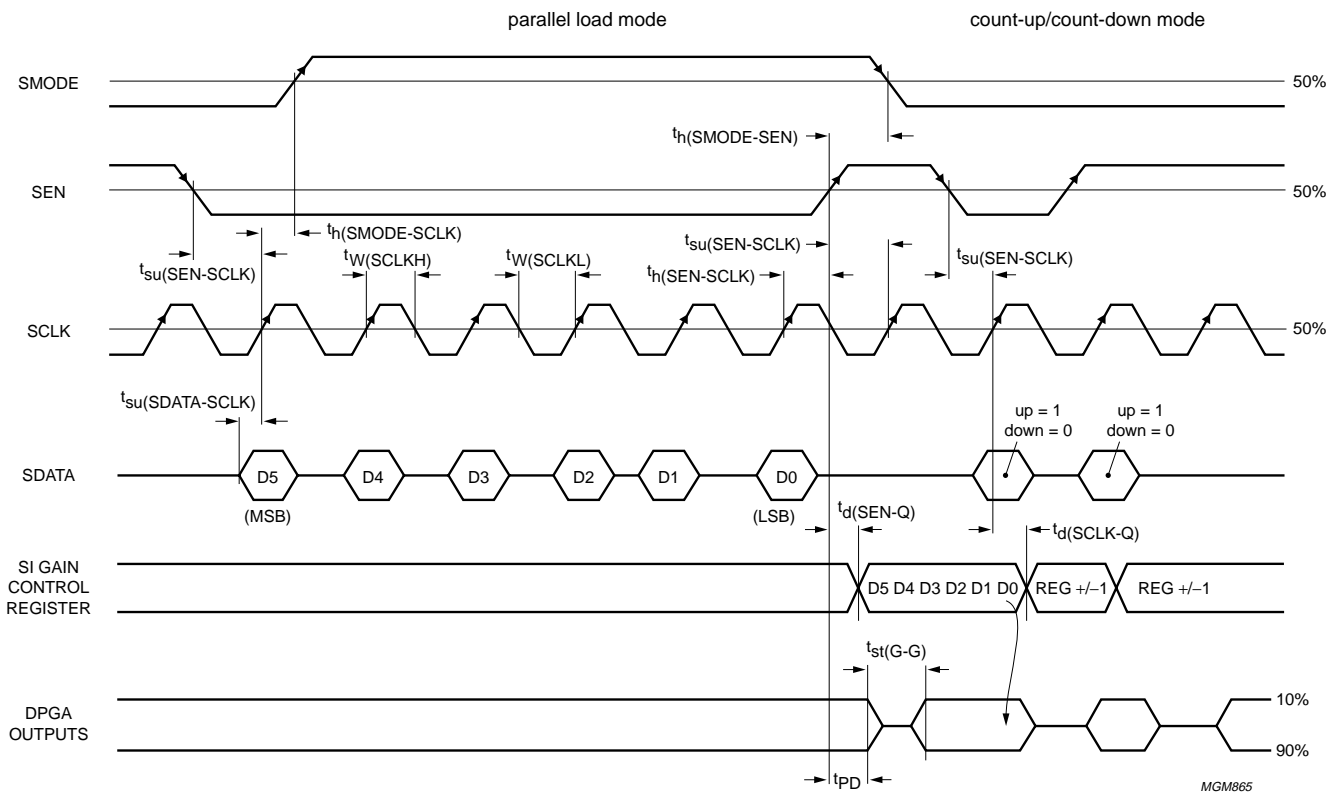

Fig.4 Timing diagram of serial interface.

MGM865

Dual 8-bit, 100 Msps A/D converter with DPGA

TDA8798

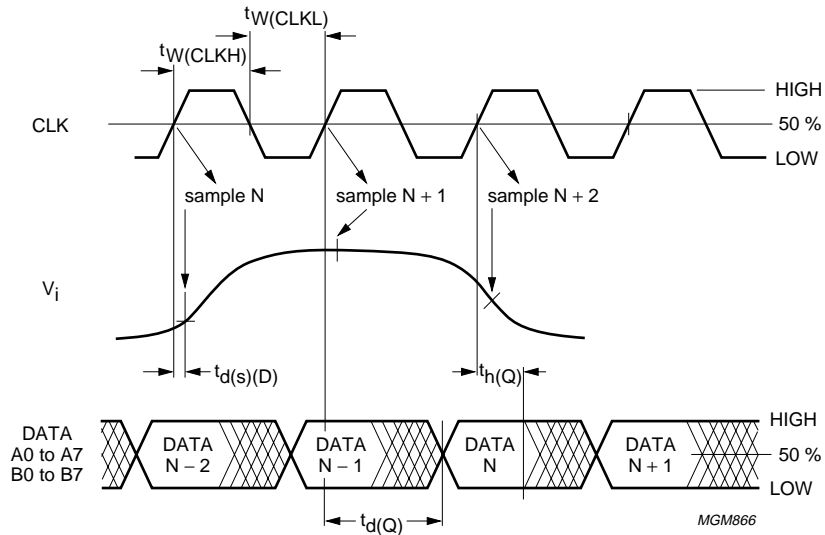

Fig.5 Timing diagram for the ADC.

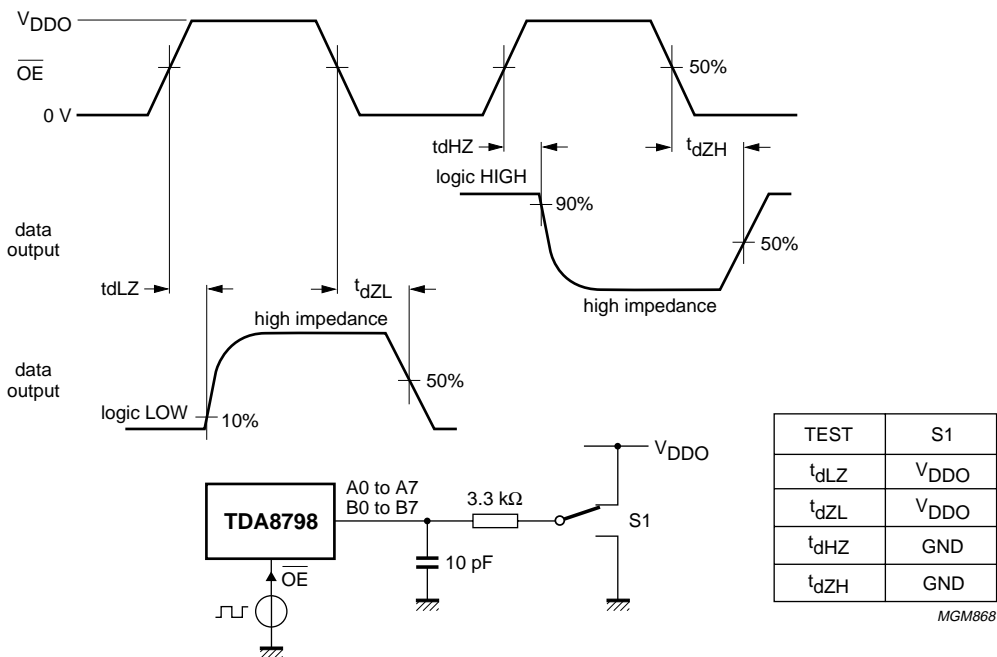

Fig.6 Timing diagram and test conditions of 3-state output delay time.



# Dual 8-bit, 100 Msps A/D converter with DPGA

TDA8798

## TEST AND APPLICATION INFORMATION

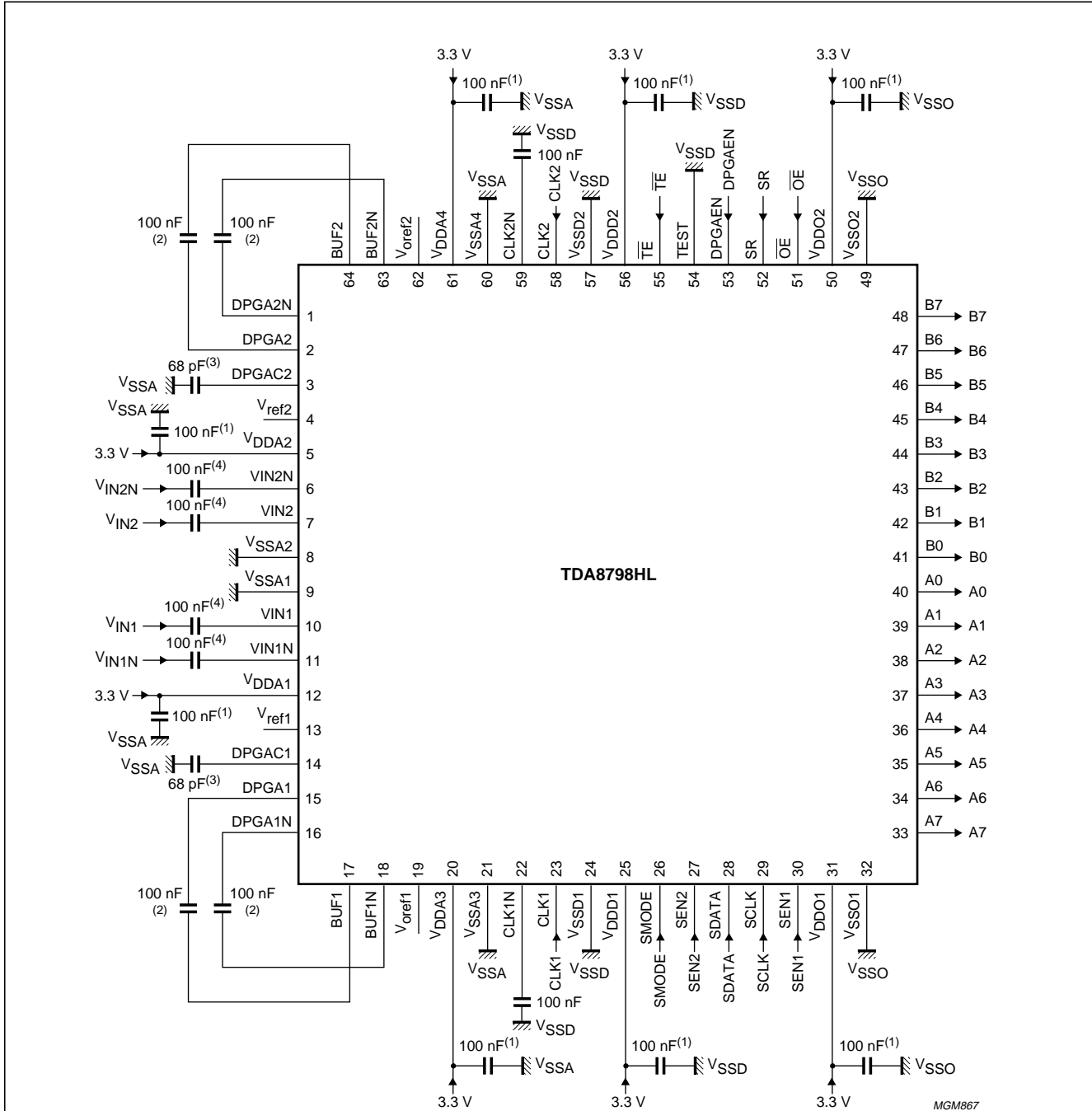

Analog and digital supplies must be separate and decoupled.

- (1) Supply decoupling capacitor must be placed as close as possible to the chip's pin. Value may need changing depending on the external filter characteristics.
- (2) Capacitor may be replaced when an external filter is used with AC coupling.
- (3) Capacitor value may be changed to adjust settling time between DPGA gain changes.
- (4) Capacitor value may need changing depending on the high-pass cut-off frequency of the external filter.

Fig.7 Application diagram.

# Dual 8-bit, 100 Msps A/D converter with DPGA

TDA8798

## INTERNAL PIN CONFIGURATIONS

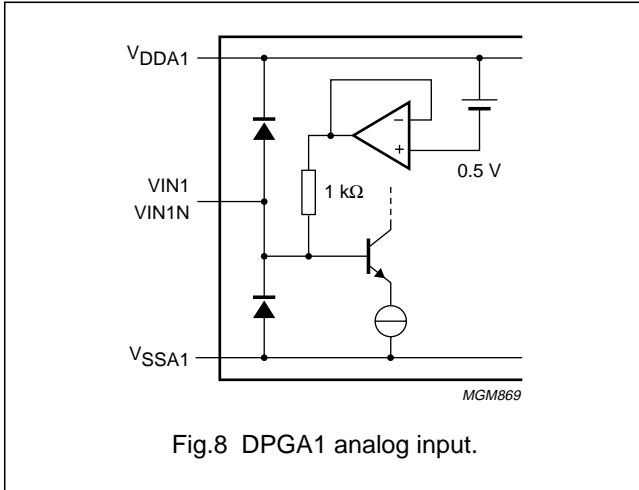

Fig.8 DPGA1 analog input.

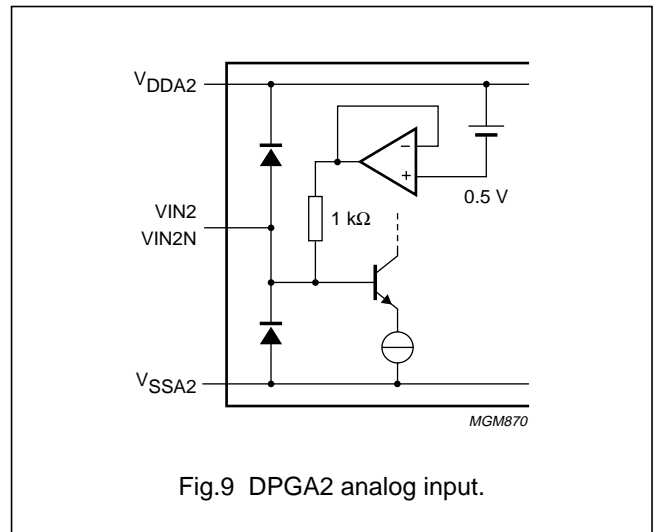

Fig.9 DPGA2 analog input.

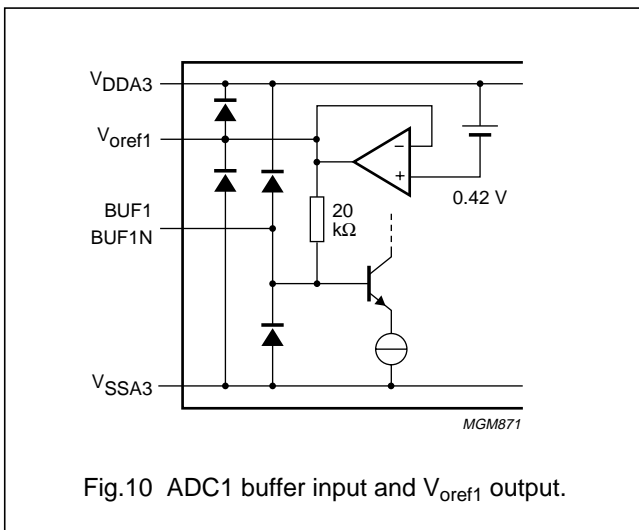

Fig.10 ADC1 buffer input and  $V_{oref1}$  output.

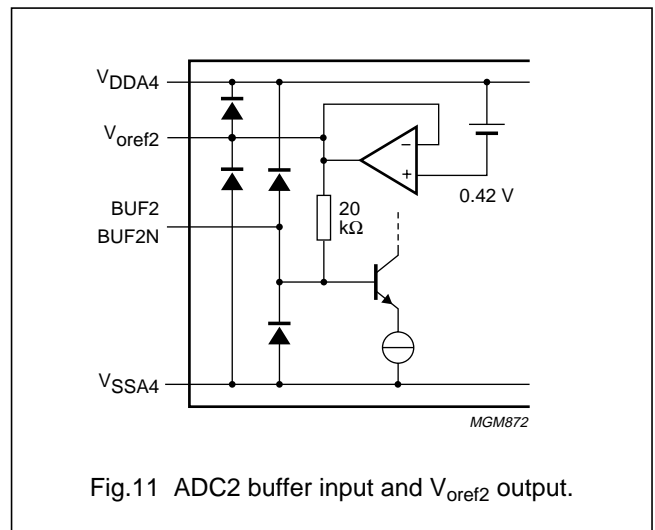

Fig.11 ADC2 buffer input and  $V_{oref2}$  output.

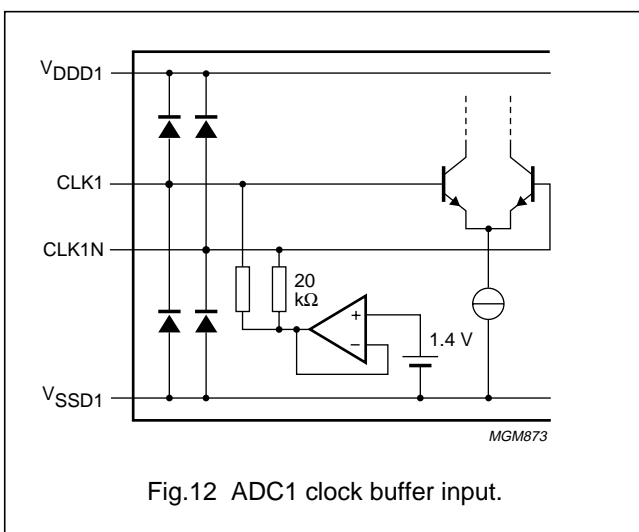

Fig.12 ADC1 clock buffer input.

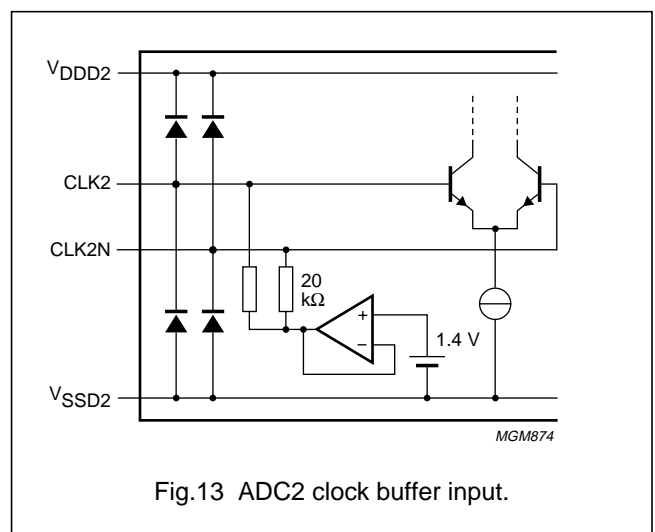

Fig.13 ADC2 clock buffer input.

# Dual 8-bit, 100 Msps A/D converter with DPGA

## TDA8798

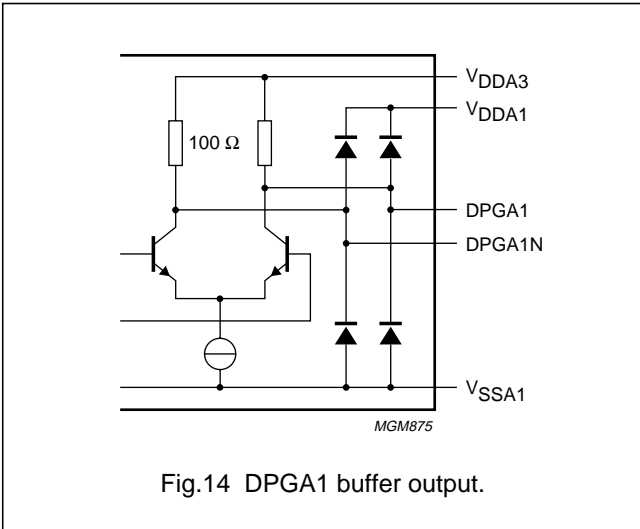

Fig.14 DPGA1 buffer output.

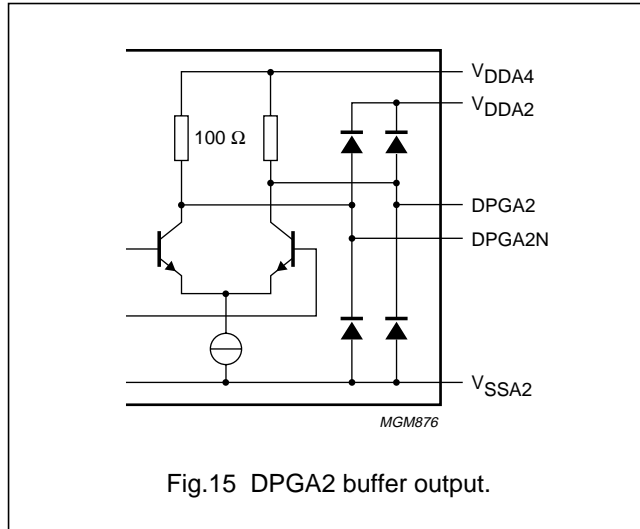

Fig.15 DPGA2 buffer output.

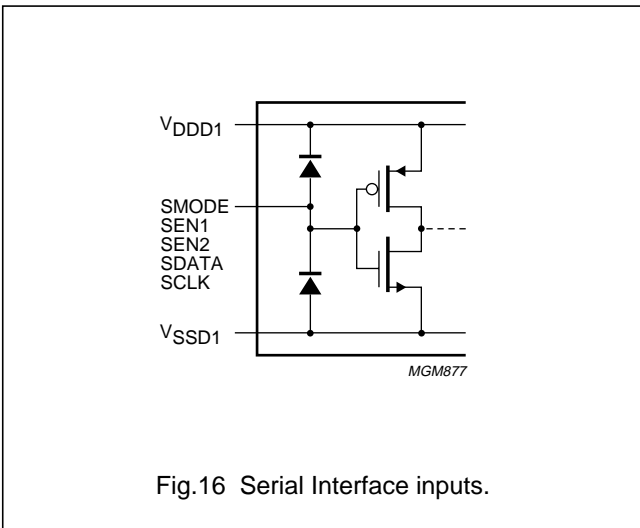

Fig.16 Serial Interface inputs.

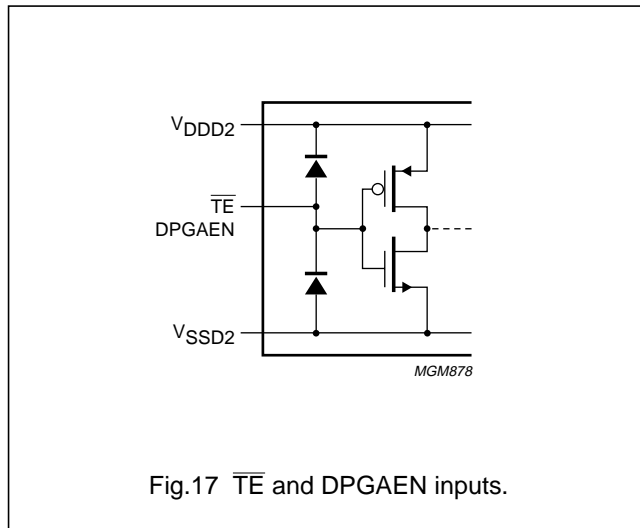

Fig.17  $\overline{TE}$  and DPGAEN inputs.

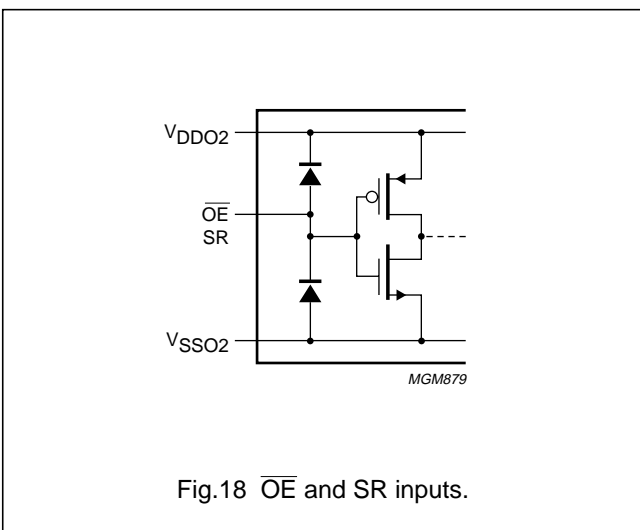

Fig.18  $\overline{OE}$  and SR inputs.

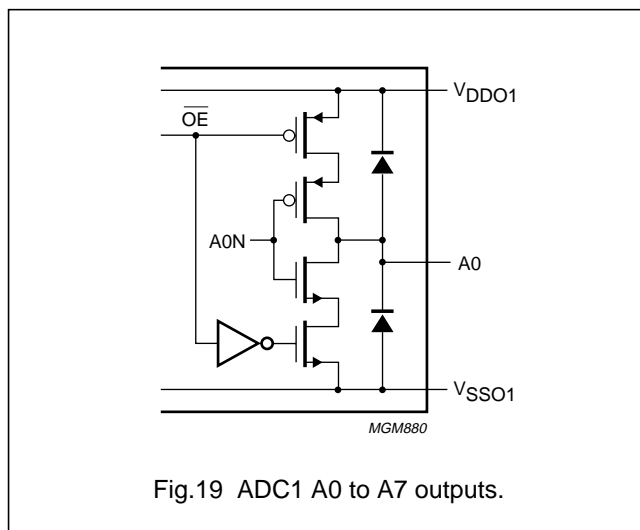

Fig.19 ADC1 A0 to A7 outputs.

Dual 8-bit, 100 Msps A/D converter with DPGA

TDA8798

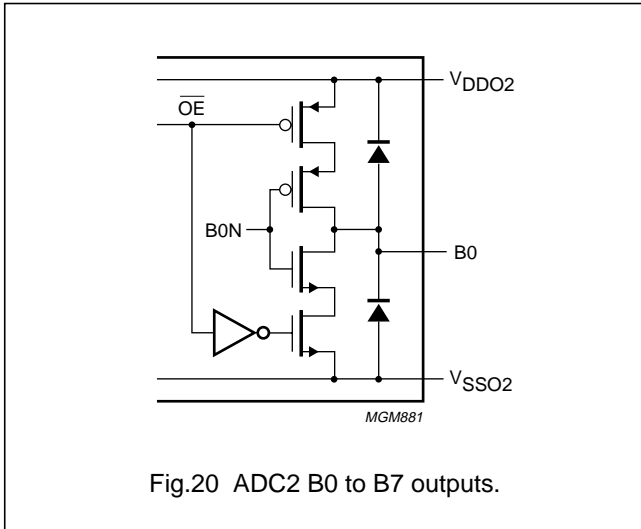

Fig.20 ADC2 B0 to B7 outputs.

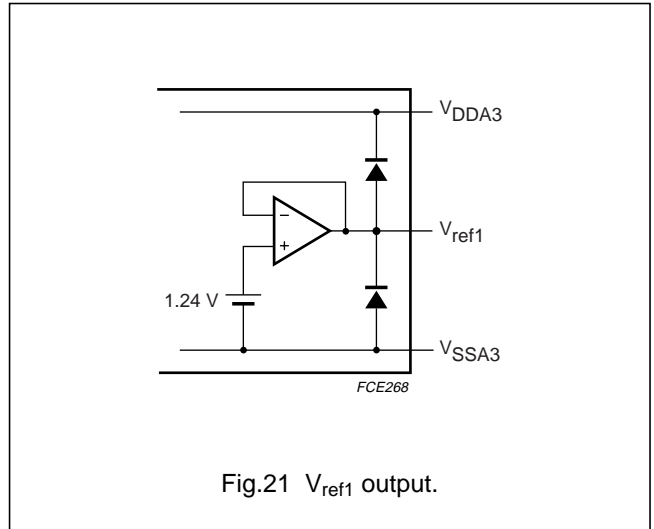

Fig.21  $V_{ref1}$  output.

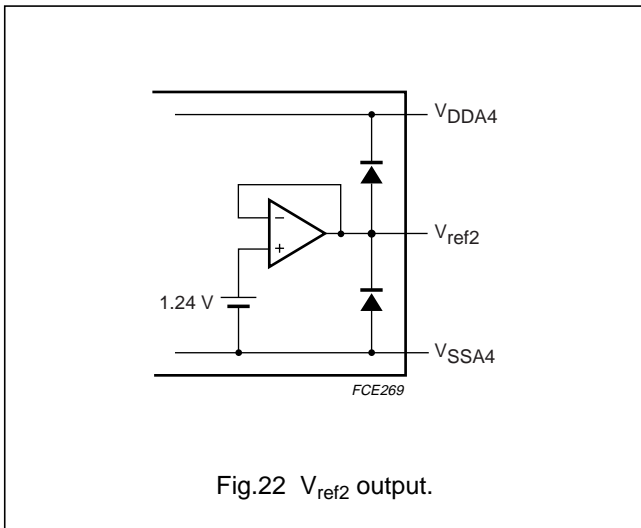

Fig.22  $V_{ref2}$  output.

# Dual 8-bit, 100 Msps A/D converter with DPGA

TDA8798

## PACKAGE OUTLINE

LQFP64: plastic low profile quad flat package; 64 leads; body 10 x 10 x 1.4 mm

SOT314-2

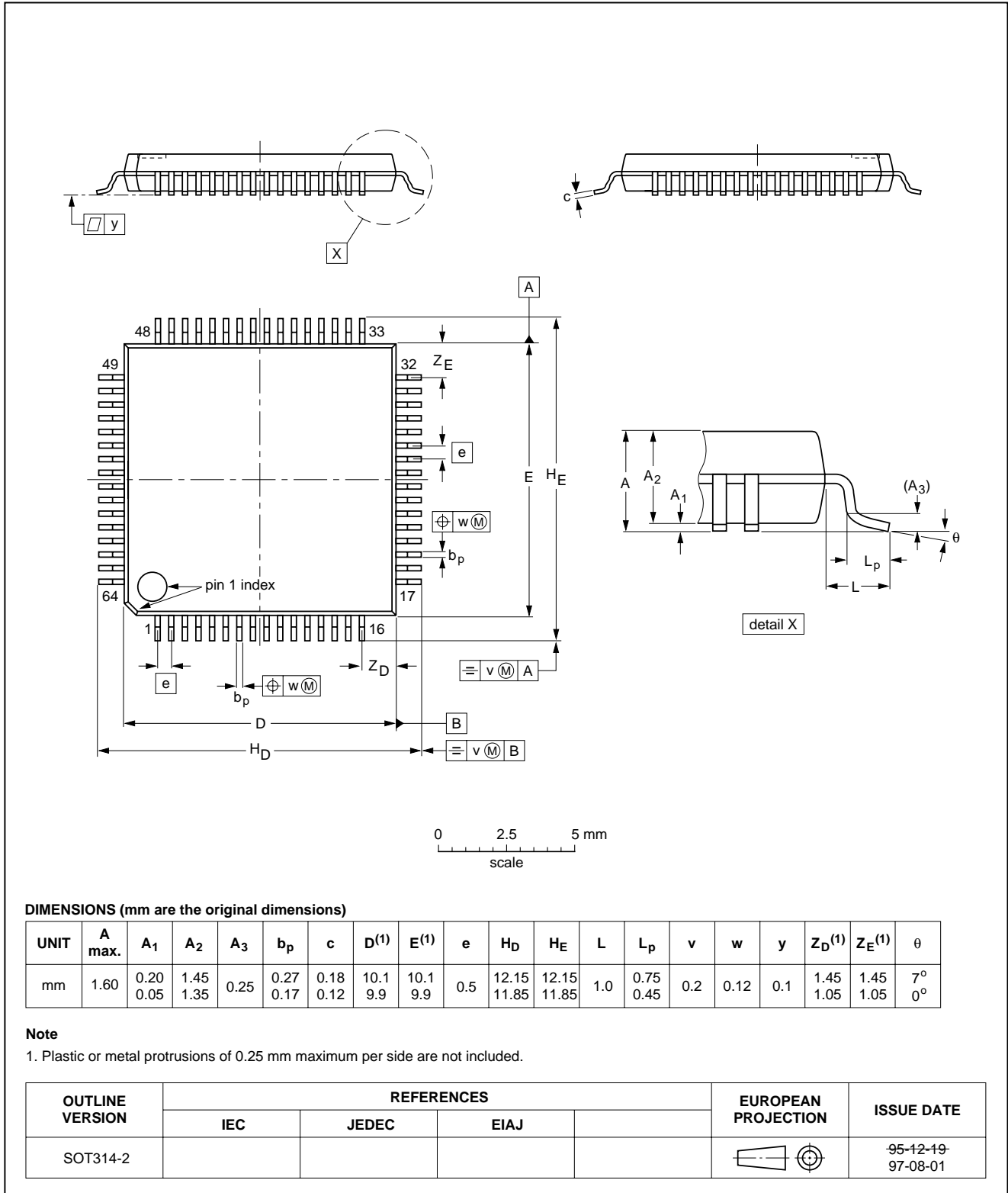

## Dual 8-bit, 100 Msps A/D converter with DPGA

TDA8798

### SOLDERING

#### Introduction to soldering surface mount packages

This text gives a very brief insight to a complex technology. A more in-depth account of soldering ICs can be found in our "Data Handbook IC26; Integrated Circuit Packages" (document order number 9398 652 90011).

There is no soldering method that is ideal for all surface mount IC packages. Wave soldering is not always suitable for surface mount ICs, or for printed-circuit boards with high population densities. In these situations reflow soldering is often used.

#### Reflow soldering

Reflow soldering requires solder paste (a suspension of fine solder particles, flux and binding agent) to be applied to the printed-circuit board by screen printing, stencilling or pressure-syringe dispensing before package placement.

Several methods exist for reflowing; for example, infrared/convection heating in a conveyor type oven. Throughput times (preheating, soldering and cooling) vary between 100 and 200 seconds depending on heating method.

Typical reflow peak temperatures range from 215 to 250 °C. The top-surface temperature of the packages should preferably be kept below 230 °C.

#### Wave soldering

Conventional single wave soldering is not recommended for surface mount devices (SMDs) or printed-circuit boards with a high component density, as solder bridging and non-wetting can present major problems.

To overcome these problems the double-wave soldering method was specifically developed.

If wave soldering is used the following conditions must be observed for optimal results:

- Use a double-wave soldering method comprising a turbulent wave with high upward pressure followed by a smooth laminar wave.

- For packages with leads on two sides and a pitch (e):
  - larger than or equal to 1.27 mm, the footprint longitudinal axis is **preferred** to be parallel to the transport direction of the printed-circuit board;
  - smaller than 1.27 mm, the footprint longitudinal axis **must** be parallel to the transport direction of the printed-circuit board.

The footprint must incorporate solder thieves at the downstream end.

- For packages with leads on four sides, the footprint must be placed at a 45° angle to the transport direction of the printed-circuit board. The footprint must incorporate solder thieves downstream and at the side corners.

During placement and before soldering, the package must be fixed with a droplet of adhesive. The adhesive can be applied by screen printing, pin transfer or syringe dispensing. The package can be soldered after the adhesive is cured.

Typical dwell time is 4 seconds at 250 °C.

A mildly-activated flux will eliminate the need for removal of corrosive residues in most applications.

#### Manual soldering

Fix the component by first soldering two diagonally-opposite end leads. Use a low voltage (24 V or less) soldering iron applied to the flat part of the lead. Contact time must be limited to 10 seconds at up to 300 °C.

When using a dedicated tool, all other leads can be soldered in one operation within 2 to 5 seconds between 270 and 320 °C.

Dual 8-bit, 100 Msps A/D converter with  
DPGA

TDA8798

## Suitability of surface mount IC packages for wave and reflow soldering methods

PACKAGE	SOLDERING METHOD	
	WAVE	REFLOW <sup>(1)</sup>
BGA, SQFP	not suitable	suitable
HLQFP, HSQFP, HSOP, HTSSOP, SMS	not suitable <sup>(2)</sup>	suitable
PLCC <sup>(3)</sup> , SO, SOJ	suitable	suitable
LQFP, QFP, TQFP	not recommended <sup>(3)(4)</sup>	suitable
SSOP, TSSOP, VSO	not recommended <sup>(5)</sup>	suitable

## Notes

- All surface mount (SMD) packages are moisture sensitive. Depending upon the moisture content, the maximum temperature (with respect to time) and body size of the package, there is a risk that internal or external package cracks may occur due to vaporization of the moisture in them (the so called popcorn effect). For details, refer to the Drypack information in the "Data Handbook IC26; Integrated Circuit Packages; Section: Packing Methods".
- These packages are not suitable for wave soldering as a solder joint between the printed-circuit board and heatsink (at bottom version) can not be achieved, and as solder may stick to the heatsink (on top version).
- If wave soldering is considered, then the package must be placed at a 45° angle to the solder wave direction. The package footprint must incorporate solder thieves downstream and at the side corners.
- Wave soldering is only suitable for LQFP, TQFP and QFP packages with a pitch (e) equal to or larger than 0.8 mm; it is definitely not suitable for packages with a pitch (e) equal to or smaller than 0.65 mm.
- Wave soldering is only suitable for SSOP and TSSOP packages with a pitch (e) equal to or larger than 0.65 mm; it is definitely not suitable for packages with a pitch (e) equal to or smaller than 0.5 mm.

## DEFINITIONS

Data sheet status	
Objective specification	This data sheet contains target or goal specifications for product development.
Preliminary specification	This data sheet contains preliminary data; supplementary data may be published later.
Product specification	This data sheet contains final product specifications.
Limiting values	
Limiting values given are in accordance with the Absolute Maximum Rating System (IEC 134). Stress above one or more of the limiting values may cause permanent damage to the device. These are stress ratings only and operation of the device at these or at any other conditions above those given in the Characteristics sections of the specification is not implied. Exposure to limiting values for extended periods may affect device reliability.	
Application information	
Where application information is given, it is advisory and does not form part of the specification.	

## LIFE SUPPORT APPLICATIONS

These products are not designed for use in life support appliances, devices, or systems where malfunction of these products can reasonably be expected to result in personal injury. Philips customers using or selling these products for use in such applications do so at their own risk and agree to fully indemnify Philips for any damages resulting from such improper use or sale.

# Philips Semiconductors – a worldwide company

**Argentina:** see South America

**Australia:** 3 Figtree Drive, HOME BUSH, NSW 2140,  
Tel. +61 2 9704 8141, Fax. +61 2 9704 8139

**Austria:** Computerstr. 6, A-1101 WIEN, P.O. Box 213,  
Tel. +43 1 60 101 1248, Fax. +43 1 60 101 1210

**Belarus:** Hotel Minsk Business Center, Bld. 3, r. 1211, Volodarski Str. 6,  
220050 MINSK, Tel. +375 172 20 0733, Fax. +375 172 20 0773

**Belgium:** see The Netherlands

**Brazil:** see South America

**Bulgaria:** Philips Bulgaria Ltd., Energoproject, 15th floor,  
51 James Bourchier Blvd., 1407 SOFIA,  
Tel. +359 2 68 9211, Fax. +359 2 68 9102

**Canada:** PHILIPS SEMICONDUCTORS/COMPONENTS,  
Tel. +1 800 234 7381, Fax. +1 800 943 0087

**China/Hong Kong:** 501 Hong Kong Industrial Technology Centre,  
72 Tat Chee Avenue, Kowloon Tong, HONG KONG,  
Tel. +852 2319 7888, Fax. +852 2319 7700

**Colombia:** see South America

**Czech Republic:** see Austria

**Denmark:** Sydhavnsgade 23, 1780 COPENHAGEN V,  
Tel. +45 33 29 3333, Fax. +45 33 29 3905

**Finland:** Sinikalliontie 3, FIN-02630 ESPOO,  
Tel. +358 9 615 800, Fax. +358 9 6158 0920

**France:** 51 Rue Carnot, BP317, 92156 SURESNES Cedex,  
Tel. +33 1 4099 6161, Fax. +33 1 4099 6427

**Germany:** Hammerbrookstraße 69, D-20097 HAMBURG,  
Tel. +49 40 2353 60, Fax. +49 40 2353 6300

**Hungary:** see Austria

**India:** Philips INDIA Ltd, Band Box Building, 2nd floor,  
254-D, Dr. Annie Besant Road, Worli, MUMBAI 400 025,  
Tel. +91 22 493 8541, Fax. +91 22 493 0966

**Indonesia:** PT Philips Development Corporation, Semiconductors Division,  
Gedung Philips, Jl. Buncit Raya Kav.99-100, JAKARTA 12510,  
Tel. +62 21 794 0040 ext. 2501, Fax. +62 21 794 0080

**Ireland:** Newstead, Clonskeagh, DUBLIN 14,  
Tel. +353 1 7640 000, Fax. +353 1 7640 200

**Israel:** RAPAC Electronics, 7 Kehilat Saloniki St, PO Box 18053,  
TEL AVIV 61180, Tel. +972 3 645 0444, Fax. +972 3 649 1007

**Italy:** PHILIPS SEMICONDUCTORS, Via Casati, 23 - 20052 MONZA (MI),  
Tel. +39 039 203 6838, Fax +39 039 203 6800

**Japan:** Philips Bldg 13-37, Kohnan 2-chome, Minato-ku,  
TOKYO 108-8507, Tel. +81 3 3740 5130, Fax. +81 3 3740 5057

**Korea:** Philips House, 260-199 Itaewon-dong, Yongsan-ku, SEOUL,  
Tel. +82 2 709 1412, Fax. +82 2 709 1415

**Malaysia:** No. 76 Jalan Universiti, 46200 PETALING JAYA, SELANGOR,  
Tel. +60 3 750 5214, Fax. +60 3 757 4880

**Mexico:** 5900 Gateway East, Suite 200, EL PASO, TEXAS 79905,  
Tel. +9-5 800 234 7381, Fax +9-5 800 943 0087

**Middle East:** see Italy

**Netherlands:** Postbus 90050, 5600 PB EINDHOVEN, Bldg. VB,  
Tel. +31 40 27 82785, Fax. +31 40 27 88399

**New Zealand:** 2 Wagener Place, C.P.O. Box 1041, AUCKLAND,  
Tel. +64 9 849 4160, Fax. +64 9 849 7811

**Norway:** Box 1, Manglerud 0612, OSLO,  
Tel. +47 22 74 8000, Fax. +47 22 74 8341

**Pakistan:** see Singapore

**Philippines:** Philips Semiconductors Philippines Inc.,  
106 Valero St. Salcedo Village, P.O. Box 2108 MCC, MAKATI,  
Metro MANILA, Tel. +63 2 816 6380, Fax. +63 2 817 3474

**Poland:** Al.Jerozolimskie 195 B, 02-222 WARSAW,  
Tel. +48 22 5710 000, Fax. +48 22 5710 001

**Portugal:** see Spain

**Romania:** see Italy

**Russia:** Philips Russia, Ul. Usatcheva 35A, 119048 MOSCOW,  
Tel. +7 095 755 6918, Fax. +7 095 755 6919

**Singapore:** Lorong 1, Toa Payoh, SINGAPORE 319762,  
Tel. +65 350 2538, Fax. +65 251 6500

**Slovakia:** see Austria

**Slovenia:** see Italy

**South Africa:** S.A. PHILIPS Pty Ltd., 195-215 Main Road Martindale,  
2092 JOHANNESBURG, P.O. Box 58088 Newville 2114,  
Tel. +27 11 471 5401, Fax. +27 11 471 5398

**South America:** Al. Vicente Pinzon, 173, 6th floor,  
04547-130 SÃO PAULO, SP, Brazil,  
Tel. +55 11 821 2333, Fax. +55 11 821 2382

**Spain:** Balmes 22, 08007 BARCELONA,  
Tel. +34 93 301 6312, Fax. +34 93 301 4107

**Sweden:** Kottbygatan 7, Akalla, S-16485 STOCKHOLM,  
Tel. +46 8 5985 2000, Fax. +46 8 5985 2745

**Switzerland:** Allmendstrasse 140, CH-8027 ZÜRICH,  
Tel. +41 1 488 2741 Fax. +41 1 488 3263

**Taiwan:** Philips Semiconductors, 6F, No. 96, Chien Kuo N. Rd., Sec. 1,  
TAIPEI, Taiwan Tel. +886 2 2134 2886, Fax. +886 2 2134 2874

**Thailand:** PHILIPS ELECTRONICS (THAILAND) Ltd.,  
209/2 Sanpavuth-Bangna Road Prakanong, BANGKOK 10260,  
Tel. +66 2 745 4090, Fax. +66 2 398 0793

**Turkey:** Yukari Dudullu, Org. San. Blg., 2.Cad. Nr. 28 81260 Umraniye,  
ISTANBUL, Tel. +90 216 522 1500, Fax. +90 216 522 1813

**Ukraine:** PHILIPS UKRAINE, 4 Patrice Lumumba str., Building B, Floor 7,  
252042 KIEV, Tel. +380 44 264 2776, Fax. +380 44 268 0461

**United Kingdom:** Philips Semiconductors Ltd., 276 Bath Road, Hayes,  
MIDDLESEX UB3 5BX, Tel. +44 208 730 5000, Fax. +44 208 754 8421

**United States:** 811 East Arques Avenue, SUNNYVALE, CA 94088-3409,  
Tel. +1 800 234 7381, Fax. +1 800 943 0087

**Uruguay:** see South America

**Vietnam:** see Singapore

**Yugoslavia:** PHILIPS, Trg N. Pasica 5/v, 11000 BEOGRAD,  
Tel. +381 11 62 5344, Fax.+381 11 63 5777

**For all other countries apply to:** Philips Semiconductors,  
International Marketing & Sales Communications, Building BE-p, P.O. Box 218,  
5600 MD EINDHOVEN, The Netherlands, Fax. +31 40 27 24825

**Internet:** <http://www.semiconductors.philips.com>

© Philips Electronics N.V. 1999

SCA 68

All rights are reserved. Reproduction in whole or in part is prohibited without the prior written consent of the copyright owner.

The information presented in this document does not form part of any quotation or contract, is believed to be accurate and reliable and may be changed without notice. No liability will be accepted by the publisher for any consequence of its use. Publication thereof does not convey nor imply any license under patent- or other industrial or intellectual property rights.

Printed in The Netherlands

545004/25/02/pp24

Date of release: 1999 Sep 16

Document order number: 9397 750 05466

*Let's make things better.*

**Philips**  
Semiconductors



**PHILIPS**