

CAR RADIO SIGNAL PROCESSOR

- HIGH PERFORMANCE SIGNAL PROCESSOR FOR CAR RADIO SYSTEMS
- DEVICE INCLUDES AUDIO PROCESSOR, STEREO DECODER, NOISEBLANKER AND MULTIPATH DETECTOR
- NO EXTERNAL COMPONENTS REQUIRED
- FULLY PROGRAMMABLE VIA I²C BUS
- LOW DISTORTION
- LOW NOISE

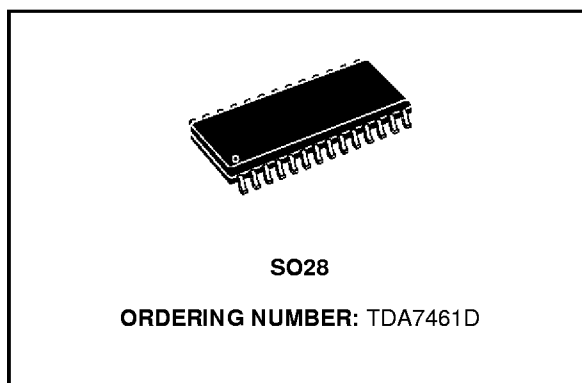

DESCRIPTION

The TDA7461 is a high performance signal processor specifically designed for car radio applications.

The device includes a complete audioprocessor and a stereo decoder with noiseblanker, stereoblend and all signal processing functions necessary for state-of-the-art as well as future car radio systems.

Switched-capacitors design technique allows to obtain all these features without external compo-

nents or adjustments. This means that higher quality and reliability walks alongside an overall cost saving.

The CSP is fully programmable by I²C bus interface allowing to customize key device parameters and especially filter characteristics.

The BICMOS process combined with the optimized signal processing assure low noise and low distortion performances.

BLOCK DIAGRAM

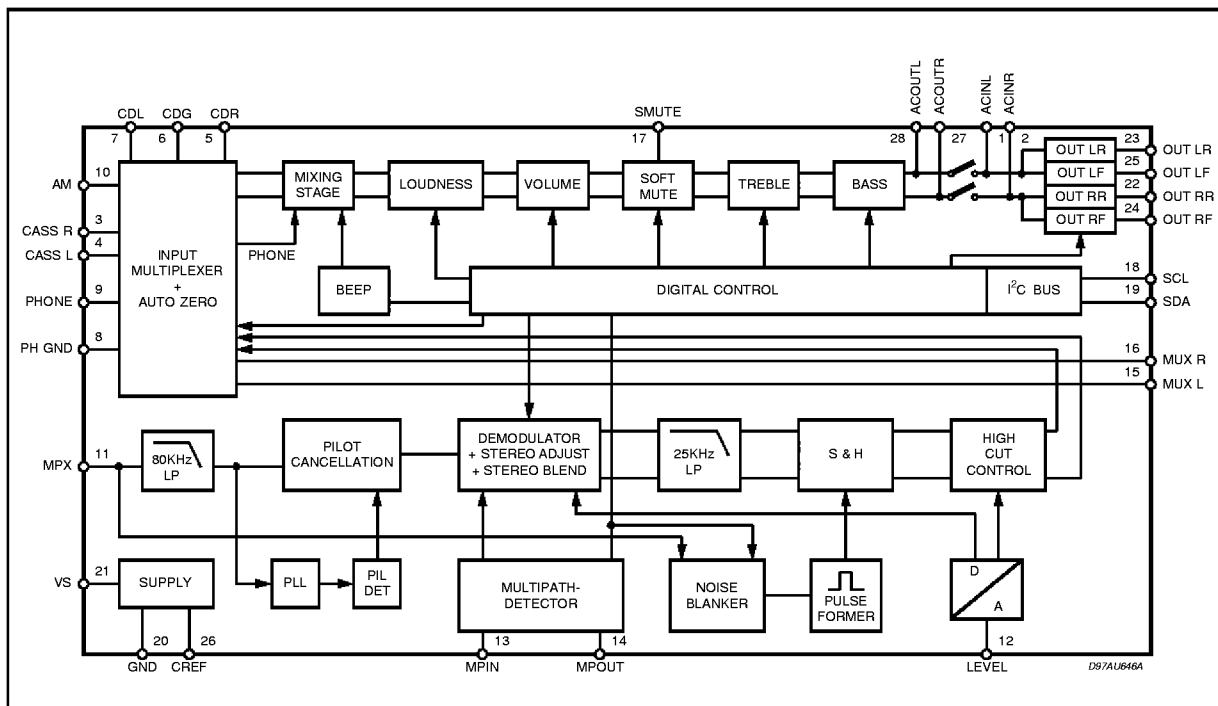

ABSOLUTE MAXIMUM RATINGS

Symbol	Parameter	Value	Unit
V _s	Operating Supply Voltage	10.5	V
T _{amb}	Operating Ambient Temperature Range	-40 to 80	°C
T _{stg}	Operating Storage Temperature Range	-55 to 150	°C

SUPPLY

Symbol	Parameter	Test Condition	Min.	Typ.	Max.	Unit
V _s	Supply Voltage		7.5	9	10	V
I _s	Supply Current	V _S = 9V	25	30	35	mA
SVRR	Ripple Rejection @ 1KHz	Audioprocessor (all filters flat)		60		dB
		Stereodecoder + Audioprocessor		45		dB

ESD

All pins are protected against ESD according to the MIL883 standard.

PIN CONNECTION

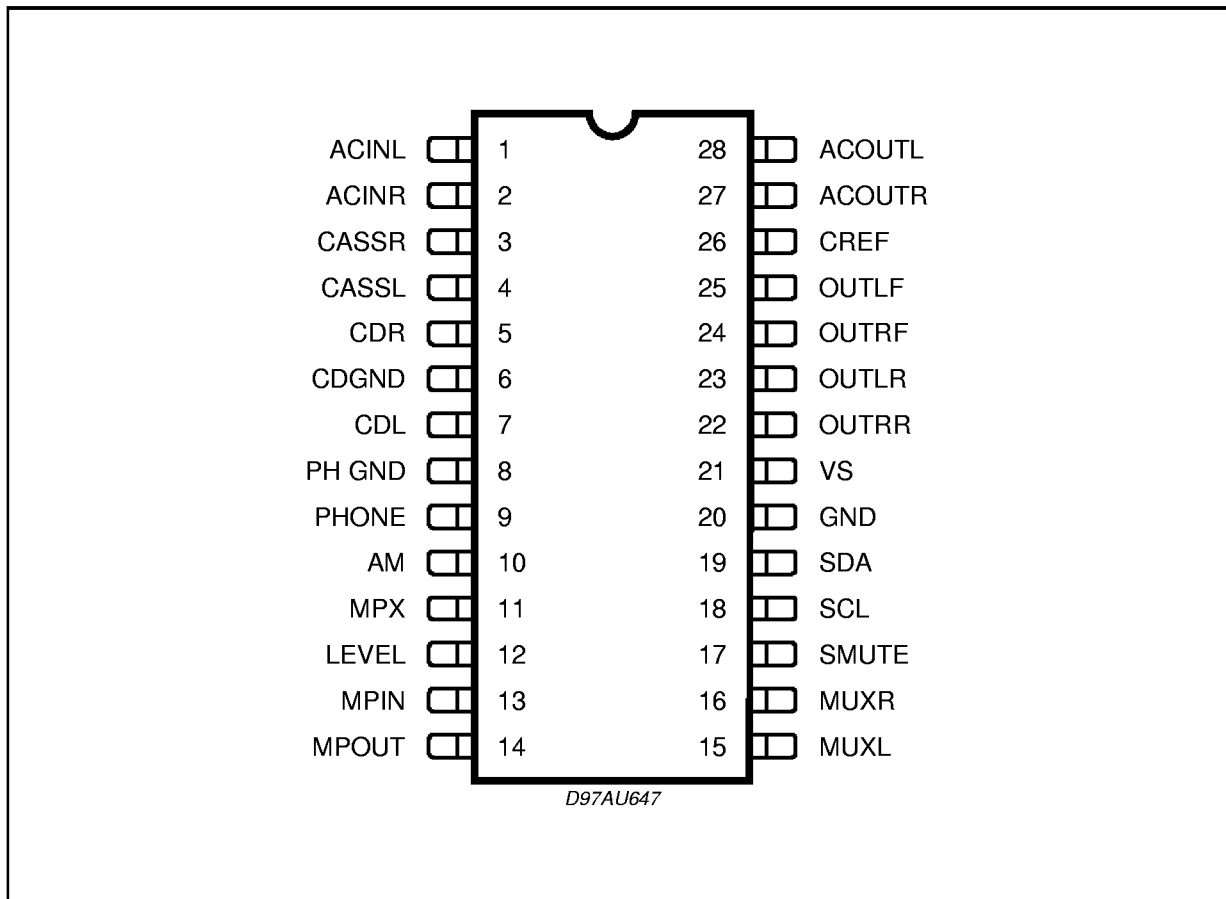

THERMAL DATA

Symbol	Parameter	Value	Unit
R _{th-jpins}	Thermal Resistance Junction-pins Max	85	°C/W

PIN DESCRIPTION

N.	Name	Function	Type
1	ACINL	Speaker Stage Input Left	I
2	ACINR	Speaker Stage Input Right	I
3	CASSR	Cassette Input Right	I
4	CASSL	Cassette Input Left	I
5	CDR	CD Right Channel Input	I
6	CDGND	Ground reference CD	I
7	CDL	CD Left Channel Input	I
8	PHGND	Phone Ground	I
9	PHONE	Phone Input	I
10	AM	AM Input	I
11	MPX	FM Input (MPX)	I
12	LEVEL	Level Input Stereodecoder	I
13	MPIN	Multipath Detector Input	I
14	MPOUT	Multipath Detector Output	O
15	MUXL	Multiplexer Output Left Channel (Stereodecoder Output left selectable ¹)	O
16	MUXR	Multiplexer Output Right Channel (Stereodecoder Output right selectable ¹)	O
17	SMUTE	Soft Mute Drive	I
18	SCL	I ² C Clock Line	I/O
19	SDA	I ² C Data Line	I/O
20	GND	Supply Ground	S
21	VS	Supply Voltage	S
22	OUTRR	Right Rear Speaker Output	O
23	OUTLR	Left Rear Speaker Output	O
24	OUTRF	Right Front Spaeaker Output	O
25	OUTLF	Left Front Speaker Output	O
26	CREF	Reference Capacitor Pin	S
27	ACOUTR	Pre-speaker AC Output Right Channel	O
28	ACOURL	Pre-speaker AC Output Left Channel	O

(1) See databyte specification - speaker attenuators

Pin type legenda:

I = Input

O = Output

I/O = Input/Output

S = Supply

AUDIO PROCESSOR PART

Input Multiplexer

- Fully differential or quasi-differential CD and cassette stereo input
- AM mono or stereo input
- Phone differential or single ended input
- Internal beep with 2 frequencies (selectable)
- Mixable phone and beep signals

Loudness

- Second order frequency response
- Programmable center frequency and quality factor
- 15 x 1dB steps
- Selectable flat-mode (constant attenuation)

Volume control

- 1dB attenuator
- Max. gain 20dB
- Max. attenuation 79dB
- Soft-step gain control

Bass Control

- 2nd order frequency response
- Center frequency programmable in 4(5) steps
- DC gain programmable
- 7 x 2dB steps

Treble Control

- 2nd order frequency response
- Center frequency programmable in 4 steps
- 7 x 2dB steps

Speaker Control

- 4 independent speaker controls (1dB steps control range 50dB)

Mute Functions

- Direct mute
- Digitally controlled softmute with 4 programmable time constants

ELECTRICAL CHARACTERISTICS ($V_s = 9V$; $T_{amb} = 25^\circ C$; $R_L = 10K\Omega$; all gains = 0dB; $f = 1KHz$; unless otherwise specified).

Symbol	Parameter	Test Condition	Min.	Typ.	Max.	Unit
INPUT SELECTOR						
R_{in}	Input Resistance	all inputs except Phone	70	100	130	$K\Omega$
V_{CL}	Clipping Level		2.2	2.6		V_{RMS}
S_{IN}	Input Separation		80	100		dB
$G_{IN MIN}$	Min. Input Gain		-1	0	1	dB
$G_{IN MAX}$	Max. Input Gain			14		dB
G_{STEP}	Step Resolution			2		dB
V_{DC}	DC Steps	Adjacent Gain Step		2		mV
		G_{MIN} to G_{MAX}		6		mV
DIFFERENTIAL CD STEREO INPUT						
R_{in}	Input Resistance	Differential	70	100	130	$K\Omega$
		Common Mode	20	30	40	$K\Omega$
CMRR	Common Mode Rejection Ratio	$V_{CM} = 1V_{RMS} @ 1KHz$	45	70		dB
		$V_{CM} = 1V_{RMS} @ 10KHz$		60		dB
e_n	Output Noise @ Speaker Output	20Hz to 20KHz flat; all stages 0dB		9		μV
DIFFERENTIAL PHONE INPUT						
R_{in}	Input Resistance	Differential	10	15	20	$K\Omega$
		Common Mode	20	30	40	$K\Omega$
CMRR	Common Mode Rejection Ratio	$V_{CM} = 1V_{RMS} @ 1KHz$	45	70		dB
		$V_{CM} = 1V_{RMS} @ 10KHz$	45	60		dB

ELECTRICAL CHARACTERISTICS (continued)

Symbol	Parameter	Test Condition	Min.	Typ.	Max.	Unit
BEEP CONTROL						
V _{RMS}	Beep Level			350		mV
f _{BMIN}	Lower Beep Frequency			600		Hz
f _{BMAX}	Higher Beep Frequency			1.2		KHz
MIXING CONTROL						
M _{LEVEL}	Mixing Level	Source		0		dB
		Source		-6		dB
		Source		-12		dB
		Beep/Phone		0		dB
VOLUME CONTROL						
G _{MAX}	Max Gain			20		dB
A _{MAX}	Max Attenuation			79		dB
A _{STEP}	Step Resolution			1		dB
EA	Attenuation Set Error	G = -20 to 20dB	-1.25	0	1.25	dB
		G = -60 to 20dB	-4	0	3	dB
ET	Tracking Error				2	dB
V _{DC}	DC Steps	Adjacent Attenuation Steps		0.1	3	mV
		From 0dB to G _{MIN}		0.5	5	mV
LOUDNESS CONTROL						
A _{STEP}	Step Resolution			1		dB
A _{MAX}	Max. Attenuation			15		dB
f _{CMIN}	Lower Center Frequency			200		Hz
f _{CMAx}	Higher Center Frequency			400		Hz
SOFT MUTE						
A _{MUTE}	Mute Attenuation		70	100		dB
T _D	Delay Time	T1		0.48		ms
		T2		0.96		ms
		T3		40.4		ms
		T4		324		ms
V _{THlow}	Low Threshold for SM Pin ¹				1	V
V _{THhigh}	High Threshold for SM Pin		2.5			V
R _{PD}	Internal Pull-up Resistor		70	100	130	K Ω
SOFT STEP						
T _{sw}	Switch Time			10		ms

1) The SM pin is active low (Mute = 0)

ELECTRICAL CHARACTERISTICS (continued)

Symbol	Parameter	Test Condition	Min.	Typ.	Max.	Unit
BASS CONTROL						
C _{RANGE}	Control Range			±14		dB
A _{STEP}	Step Resolution			2		dB
f _c	Center Frequency	f _{c1}		60		Hz
		f _{c2}		70		Hz
		f _{c3}		80		Hz
		f _{c4}		100 ⁽²⁾		Hz
Q _{BASS}	Quality Factor	Q ₁		1		
		Q ₂		1.25		
		Q ₃		1.5		
		Q ₄		2		
DC _{GAIN}	Bass-Dc-Gain	DC = off		0		dB
		DC = on		4.4		dB
TREBLE CONTROL						
C _{RANGE}	Control Range			±14		dB
A _{STEP}	Step Resolution			2		dB
f _c	Center Frequency	f _{c1}		10		KHz
		f _{c2}		12.5		KHz
		f _{c3}		15		KHz
		f _{c4}		17.5		KHz
SPEAKER ATTENUATORS						
C _{RANGE}	Control Range			50		dB
A _{STEP}	Step Resolution			1		dB
A _{MUTE}	Output Mute Attenuation		80	90		dB
E _E	Attenuation Set Error				2	dB
V _{DC}	DC Steps	Adjacent Attenuation Steps		0.1	5	mV
AUDIO OUTPUTS						
V _{CLIP}	Clipping Level	d = 0.3%	2.2	2.6		V _{RMS}
R _L	Output Load Resistance		2			KΩ
C _L	Output Load Capacitance				10	nF
R _{OUT}	Output Impedance			30	120	Ω
V _{DC}	DC Voltage Level			3.8		V
GENERAL						
e _{NO}	Output Noise	BW = 20 Hz to 20 KHz output muted		3		μV
		BW = 20 Hz to 20 KHz all gain = 0dB		6.5		μV
S/N	Signal to Noise Ratio	all gain = 0dB flat; V _O = 2V _{RMS}		110		dB
		bass treble at 12dB; V _O = 2.6V _{RMS}		100		dB
d	Distortion	V _{IN} = 1V _{RMS} ; all stages 0dB		0.002		%
		V _{IN} = 1V _{RMS} ; Bass & Treble = 12dB		0.05		%
SC	Channel separation Left/Right		80	100		dB
E _T	Total Tracking Error	A _v = 0 to -20dB		0	1	dB
		A _v = -20 to -60dB		0	2	dB

2) See description of Audioprocessor Part - Bass & Treble filter characteristics programming

DESCRIPTION OF THE AUDIOPROCESSOR PART

Programmable Input Matrix

The programmable input matrix of the TDA7461 offers several possibilities to adapt the audioprocessor to the desired application. In to the standard application we have:

- CD quasi differential
- Cassette stereo
- Phone differential
- AM mono
- Stereodecoder input.

The input matrix can be configured by only 2 bits:

Figure 1. Input Configuration Tree

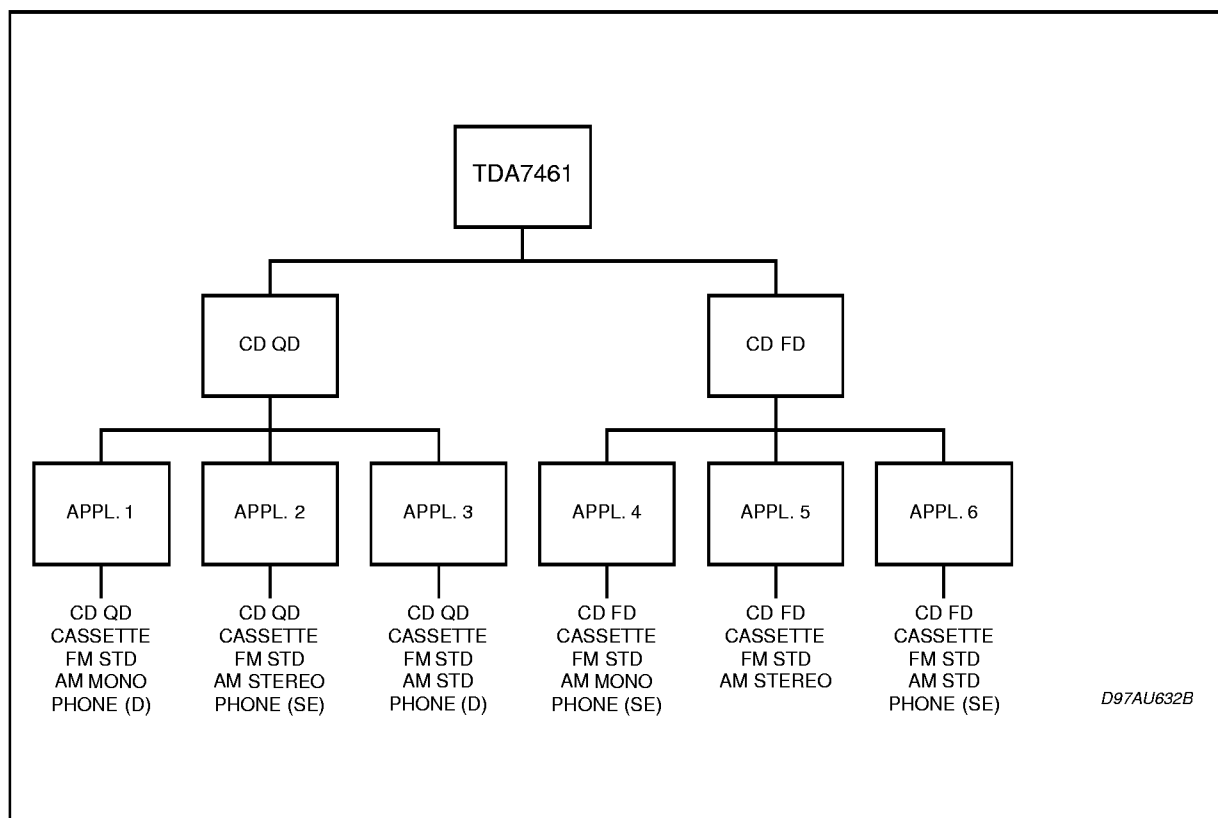

Note: in AMSTD configuration the AM mono signal is lead through the FM stereodecoder part to use its additional filters and high-cut function.

Appl. No	PIN NUMBER				Programming ¹⁾	
	4	6	7	8		
1	CD _{GND}	Phone _{GND}	Phone	AM _{MONO}	Startup:	0/xxx11xxx
2	CD _{GND}	Phone _{GND}	AM _{RIGHT}	AM _{LEFT}	Startup:	0/xxx1xxx
					FM	0/xxx11100
					AM	0/xxx01011
3	CD _{GND}	Phone _{GND}	Phone	AM _{STD}	Phone	0/xxx11010
					Startup:	0/xxx1xxx
					FM	0/xxx11100
4	CD _R _{GND}	CD _L _{GND}	Phone	AM _{MONO}	AM	0/xxx01100
					Startup:	0/xxx11010
					Phone	0/xxx0xxx
5	CD _R _{GND}	CD _L _{GND}	AM _{RIGHT}	AM _{LEFT}	Startup:	0/xxx0xxx
					FM	0/xxx10100
					AM	0/xxx00011
6	CD _R _{GND}	CD _L _{GND}	Phone	AM _{STD}	Startup:	0/xxx0xxx
					FM	0/xxx10100
					AM	0/xxx00100
					Phone	0/xxx10010

¹⁾ Syntax 0/xxx11100 means: SUBADDRESS = 0 - DATA BYTE = xxx11100 (x - don't care)

How to find the right input configuration

The best way to come to the desired configuration may be to go through the application tree from the top to the bottom while making the specific decisions.

This way will lead to one of the six possible applications. Then take the number of the application and go into the pinning table. Here you will find the special pinout as well as the special programming codes for selecting sources.

For example in Appl. 6 the TDA7461 has to be configured while startup with the databyte 0/xxxx0xxx.

To select the FM, AM or phone source the last five significant bits of subaddress 0 have to be changed, for any other source the last three bits are sufficient (see data byte specification).

Input stages

Most of the input circuits are the same as in preceding ST audioprocessors with exception of the CD inputs (see figure 2).

In the meantime there are some CD players in the market having a significant high source impedance which affects strongly the common-mode rejection of the normal differential input stage. The additional buffer of the CD input

avoids this drawback and offers the full common-mode rejection even with those CD players.

The TDA7461 can be configured with an additional input; if the AC coupling before the speaker stage is not used (bit 7 in subaddress 5 set to "1") ACINL and ACINR pins can be used as an additional stereo input.

AutoZero

In order to reduce the number of pins there is no AC coupling between the In-Gain and the following stage, so that any offset generated by or before the In-Gain stage would be transferred or even amplified to the output.

To avoid that effect a special offset cancellation stage called AutoZero is implemented.

To avoid audible clicks the audioprocessor is muted before the loudness stage during this time. In some cases, for example if the μ P is executing a refresh cycle of the I²C bus programming, it is not useful to start a new AutoZero action because no new source is selected and an undesired mute would appear at the outputs. For such applications the TDA7461 could be switched in the "Auto Zero Remain" mode (Bit 6 of the subaddress byte). If this bit is set to high, the DATABYTE 0 could be loaded without invoking the AutoZero and the old adjustment value remains.

Figure 2. Input stages

Figure 3. Loudness Attenuation @ $f_c = 400\text{Hz}$ (second order)

Figure 4. Loudness Center frequency @ Attn. = 15dB (second order)



Mixing Stage

This stage offers the possibility to mix the internal beep or the phone signal to any other source. Due to the fact that the mixing stage is also located behind the In-Gain stage fine adjustments of the main source level can be done in this way.

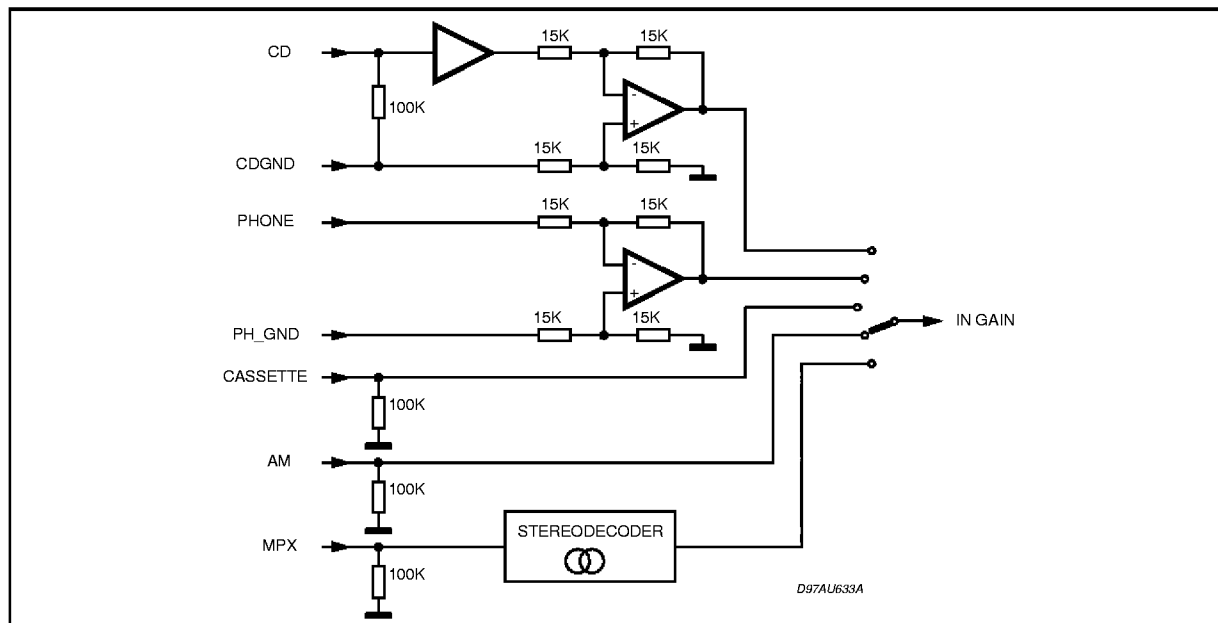
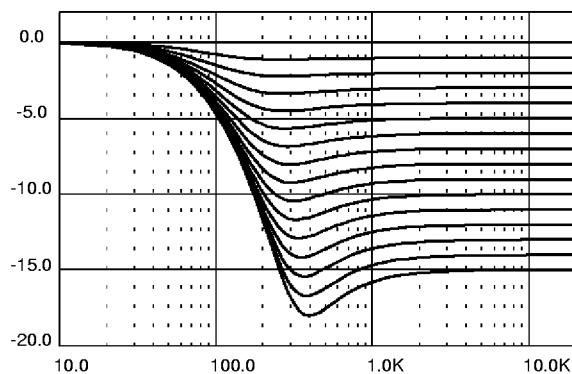
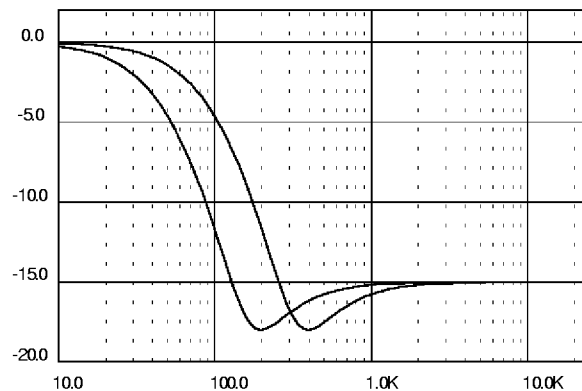
Loudness

There are four parameters programmable in the loudness stage (see fig. 3, 4, 5):

- Attenuation
- Center Frequency
- Loudness Q
- Flat Mode: in this mode the loudness stage works as a 0 - 15dB attenuator.

Softmute

The digitally controlled softmute stage allows muting/demuting the signal with a I^2C bus programmable slope. The mute process can either be activated by the softmute pin or by the I^2C bus. The slope is realized in a special S shaped curve to mute slow in the critical regions (see figure 6).

For timing purposes the Bit 3 of the I^2C bus output register is set to 1 from the start of muting until the end of demuting.

Figure 5. Loudness @ Attn. = 15dB, fc = 400Hz

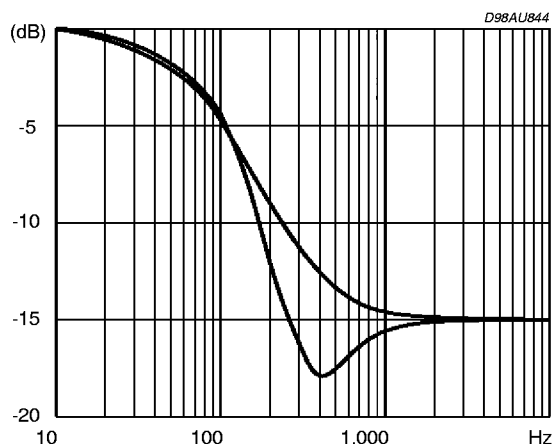

Softstep Volume

When volume level is changed often an audible click appears at the output. The root cause of those clicks could be either a DC offset before the volume stage or the sudden change of the envelope of the audio signal. With the Softstep feature both kinds of clicks could be reduced to a minimum and are no more audible (see figure 7).

Bass

There are three parameters programmable in the bass stage (see figs 8, 9, 10, 11):

- Attenuation
- Center Frequency (60, 70, 80 and 100Hz)
- Quality Factors (1, 1.25, 1.5 and 2)

DC Mode

In this mode the DC gain is increased by 4.4dB. In addition the programmed center frequency and quality factor is decreased by 25% which can be used to reach alternative center frequencies or quality factors.

Treble

There are two parameters programmable in the treble stage (see figs 12, 13):

- Attenuation
- Center Frequency (10, 12.5, 15 and 17.5kHz).

Speaker Attenuator

Due to practical aspects the steps in the speaker attenuators are not linear over the full range. At attenuations more than 24dB the steps increase from 1.5dB to 10dB (please see data byte specification).

Figure 6. Softmute Timing

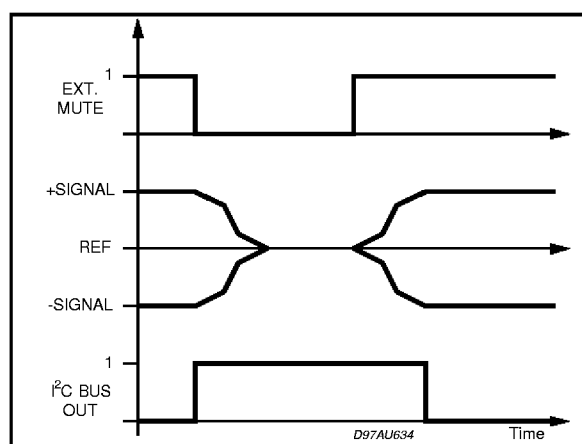

Note: Please notice that a started Mute action is always terminated and could not be interrupted by a change of the mute signal.

Figure 7. Soft Step Timing

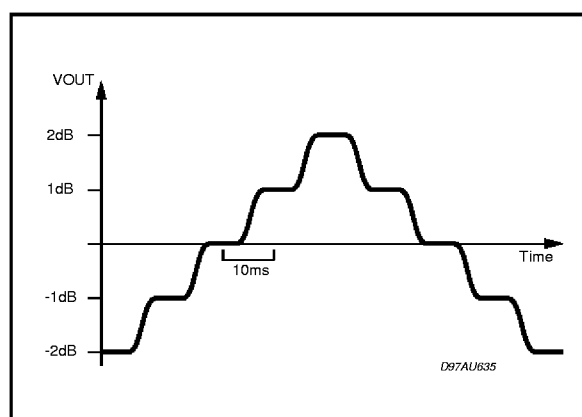

Note: For steps more than 1dB the softstep mode should be deactivated because it could generate a 1dB error during the blend-time

Figure 8. Bass Control @ $f_c = 80\text{Hz}$, $Q = 1$

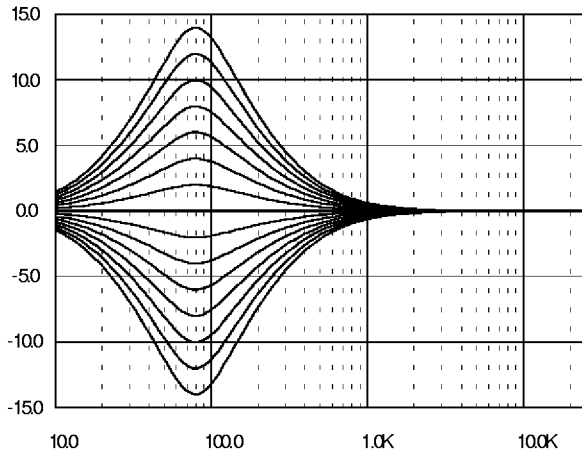

Figure 9. Bass Center @ Gain = 14dB, $Q = 1$

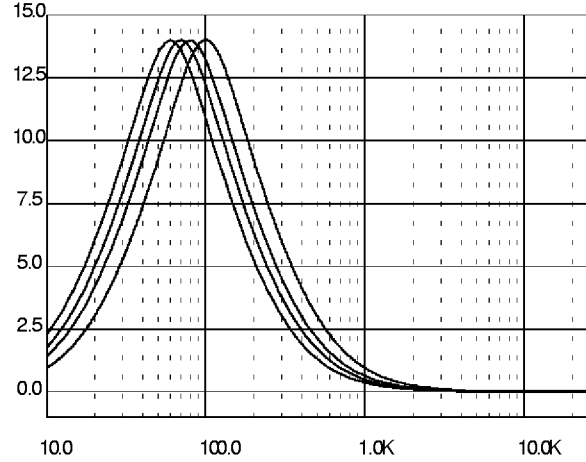

Figure 10. Bass Quality factors @ Gain = 14dB, $f_c = 80\text{Hz}$

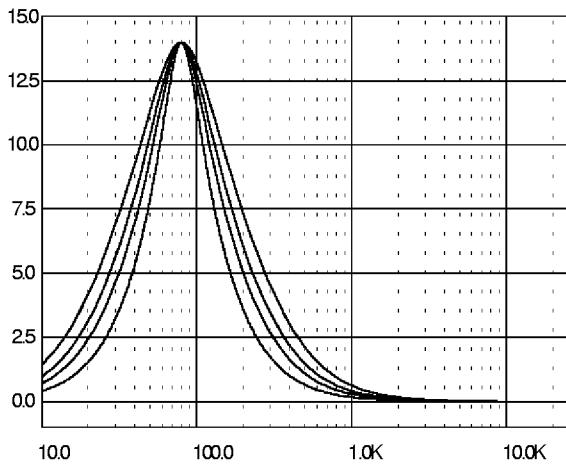
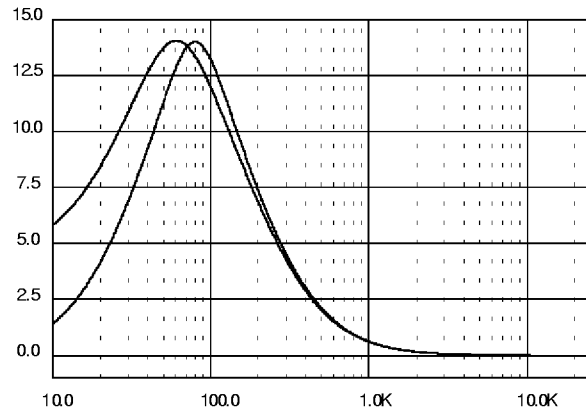

Figure 11. Bass normal and DC Mode @ Gain = 14dB, $f_c = 80\text{Hz}$



Note: In general the center frequency, Q and DC-mode can be set independently. The exception from this rule is the mode (5/xx1111xx) where the center frequency is set to 150Hz instead of 100Hz.

Figure 12. Treble Control @ $f_c = 17.5\text{KHz}$

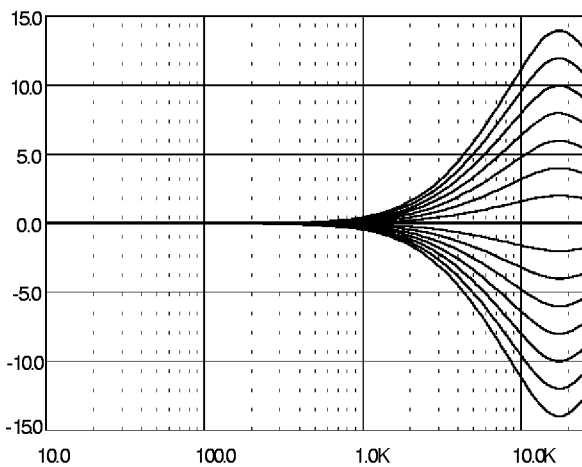
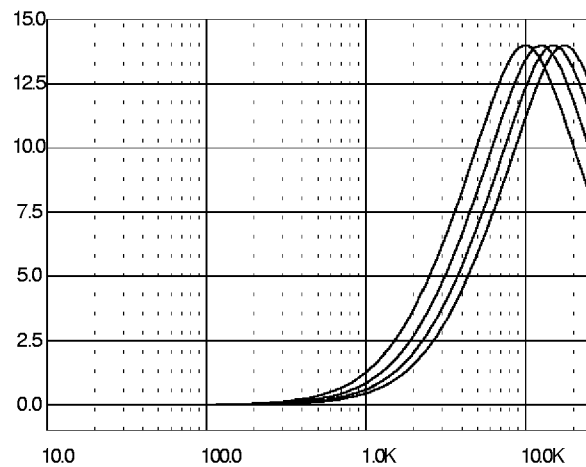

Figure 13. Treble Center Frequencies @ Gain = 14dB



STEREODECODER PART

- No external components necessary
- PLL with adjustment free fully integrated VCO
- Automatic pilot dependent MONO/STEREO switching
- Very high suppression of intermodulation and interference
- Programmable Roll-Off compensation
- Dedicated RDS Softmute
- Highcut and Stereoblend characteristics programmable in a wide range
- Internal Noiseblanker with threshold controls
- Multipath detector with programmable internal/external influence
- I²C bus control of all necessary functions

ELECTRICAL CHARACTERISTICS ($V_S = 9V$; deemphasis time constant = $50\mu s$, $V_{MPX} = 500mV$, 75KHz deviation, $f = 1KHz$. $G_i = 6dB$, $T_{amb} = 25^\circ C$; unless otherwise specified).

Symbol	Parameter	Test Condition	Min.	Typ.	Max.	Unit
V_{IN}	MPX Input Level	Input Gain = 3.5dB		0.5	1.25	V_{RMS}
R_{in}	Input Resistance			100		K Ω
G_{min}	Minimum Input Gain			3.5		dB
G_{max}	Max Input Gain			11		dB
G_{STEP}	Step Resolution			2.5		dB
SVRR	Supply Voltage Ripple Rejection	$V_{ripple} = 100mV$, $f = 1kHz$		60		dB
α	Max Channel Separation			50		dB
THD	Total Harmonic Distortion			0.02	0.3	%
$\frac{S+N}{N}$	Signal plus Noise to Noise Ratio	$S = 2V_{rms}$		91		dB
MONO/STEREO SWITCH						
V_{PTHST1}	Pilot Threshold Voltage	for Stereo, PTH = 1		15		mV
V_{PTHST0}	Pilot Threshold Voltage	for Stereo, PTH = 0		25		mV
V_{PTHMO1}	Pilot Threshold Voltage	for Mono, PTH = 1		12		mV
V_{PTHMO0}	Pilot Threshold Voltage	for Stereo, PTH = 0		19		mV
PLL						
$\Delta f/f$	Capture Range		0.5			%
DEEMPHASIS and HIGHCUT						
τ_{HC50}	Deemphasis Time Constant	Bit = 7, Subadr. 10 = 0 $V_{LEVEL} \gg V_{HCH}$		50		μs
τ_{HC75}	Deemphasis Time Constant	Bit = 7, Subadr. 10 = 1 $V_{LEVEL} \gg V_{HCH}$		75		μs
τ_{HC50}	Highcut Time Constant	Bit = 7, Subadr. 10 = 0 $V_{LEVEL} \gg V_{HCL}$		150		μs
τ_{HC75}	Highcut Time Constant	Bit = 7, Subadr. 10 = 1 $V_{LEVEL} \gg V_{HCL}$		225		μs
STEREOBLEND and HIGHCUT-CONTROL						
REF5V	Internal Reference Voltage			5		V
T_{CREF5V}	Temperature Coefficient			3300		ppm
L_{Gmin}	Min. LEVEL Gain			0		dB
L_{Gmax}	Max. LEVEL Gain			10		dB
L_{Gstep}	LEVEL Gain Step Resolution			0.67		dB
$VSBL_{min}$	Min. Voltage for Mono			33		%REF5V
$VSBL_{max}$	Max. Voltage for Mono			58		%REF5V
$VSBL_{step}$	Step Resolution			8.4		%REF5V

ELECTRICAL CHARACTERISTICS (continued)

Symbol	Parameter	Test Condition	Min.	Typ.	Max.	Unit
STEREOBLEND and HIGHCUT CONTROL						
VHCH _{min}	Min. Voltage for NO Highcut			42		%REF5V
VHCH _{max}	Max. Voltage for NO Highcut			66		%REF5V
VHCH _{step}	Step Resolution			8.4		%REF5V
VHCL _{min}	Min. Voltage for FULL High cut			17		%VHCH
VHCL _{max}	Max. Voltage for FULL High cut			33		%VHCH
Carrier and harmonic suppression at the output						
α_{19}	Pilot Signal	f = 19KHz		50		dB
α_{38}	Subcarrier	f = 38KHz		75		dB
α_{57}	Subcarrier	f = 57KHz		62		dB
α_{76}	Subcarrier	f = 76KHz		90		dB
Intermodulation (Note1)						
α_2	Pilot Signal	f _{mod} = 10KHz; f _{spur} = 1KHz;		65		dB
α_3		f _{mod} = 13KHz; f _{spur} = 1KHz;		75		dB
Traffic Radio (Note 2)						
α_{57}	Signal	f = 57KHz		70		dB
SCA - Subsidiary Communications Authorization (Note 3)						
α_{67}	Signal	f = 67KHz		75		dB
ACI - Adjacent Channel Interference (Note 4)						
α_{114}	Signal	f = 114KHz		95		dB
α_{190}	Signal	f = 190KHz		84		dB

Notes to the characteristics:

- Intermodulation Suppression: measured with: 91% pilot signal; f_m = 10kHz or 13kHz.
- Traffic Radio (V.F.) Suppression: measured with: 91% stereo signal; 9% pilot signal; f_m = 1kHz; 5% subcarrier (f = 57kHz, f_m = 23Hz AM, m = 60%)
- SCA (Subsidiary Communications Authorization) measured with: 81% mono signal; 9% pilot signal; f_m = 1kHz; 10%SCA - subcarrier (f_s = 67kHz, unmodulated).
- ACI (Adjacent Channel Interference) measured with: 90% mono signal; 9% pilot signal; f_m = 1kHz; 1% spurious signal (f_s = 110kHz or 186kHz, unmodulated).

NOISE BLANKER PART

- internal 2nd order 140kHz high pass filter
- programmable trigger threshold
- additional circuits for trigger adjustment (devia-

- tion, field-strength)
- very low offset current during hold time
- four selectable pulse suppression times

ELECTRICAL CHARACTERISTICS (continued)

Symbol	Parameter	Test Condition	Min.	Typ.	Max.	Unit	
V _{TR}	Trigger Threshold ⁰⁾¹⁾	meas. with V _{PEAK} = 0.9V	NBT = 111		30		mV _{OP}
			NBT = 110		35		mV _{OP}
			NBT = 101		40		mV _{OP}
			NBT = 100		45		mV _{OP}
			NBT = 011		50		mV _{OP}
			NBT = 010		55		mV _{OP}
			NBT = 001		60		mV _{OP}
			NBT = 000		65		mV _{OP}
V _{TRNOISE}	Noise Controlled Trigger Threshold ²⁾	meas. with V _{PEAK} = 1.5V	NCT = 00		260		mV _{OP}
			NCT = 01		220		mV _{OP}
			NCT = 10		180		mV _{OP}
			NCT = 11		140		mV _{OP}
V _{RECT}	Rectifier Voltage	V _{MPX} = 0mV		0.9		V	
		V _{MPX} = 50mV; f = 150KHz		1.7		V	
		V _{MPX} = 100mV; f = 150KHz		2.5		V	
V _{RECT DEV}	deviation dependent rectifier Voltage ³⁾	means. with V _{MPX} = 800mV (75KHz dev.)	OVD = 11		0.9(off)		V _{OP}
			OVD = 10		1.2		V _{OP}
			OVD = 01		2.0		V _{OP}
			OVD = 00		2.8		V _{OP}
V _{RECT FS}	Fieldstrength Controlled Rectifier Voltage ⁴⁾	means. with V _{MPX} = 0mV V _{LEVEL} << V _{SBL} (fully mono)	FSC = 11		0.9(off)		V
			FSC = 10		1.3		V
			FSC = 01		1.8		V
			FSC = 00		2.3		V

0) All thresholds are measured using a pulse with T_R = 2 μs, T_{HIGH} = 2 μs and T_F = 10 μs.

- 1) NBT represents the Noiseblanker-Byte bits D2; D0 for the noise blanker trigger threshold
- 2) NAT represents the Noiseblanker-Byte bit pair D4,D3 for the noise controlled trigger adjustment
- 3) OVD represents the Noiseblanker-Byte bit pair D7,D6 for the over deviation detector
- 4) FSC represents the Fieldstrength-Byte bit pair D1, D0 for the fieldstrength control

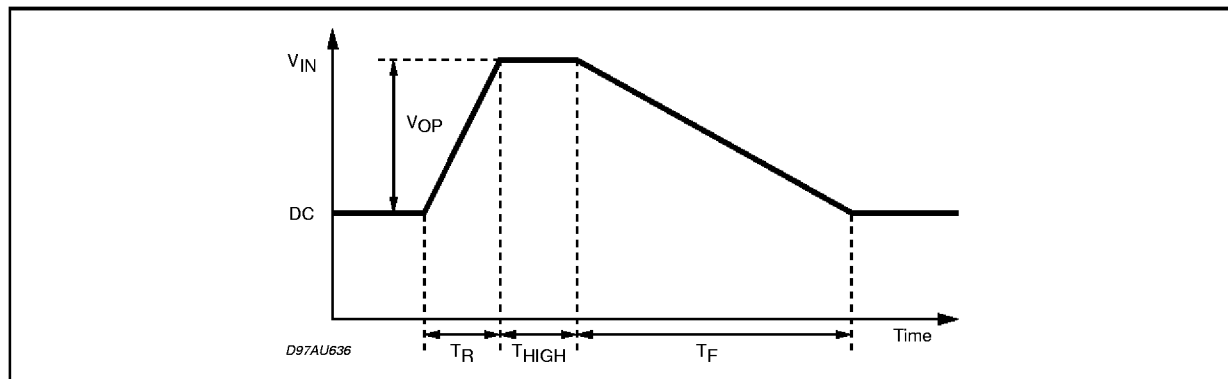

Figure 14. Trigger Threshold vs. VPEAK

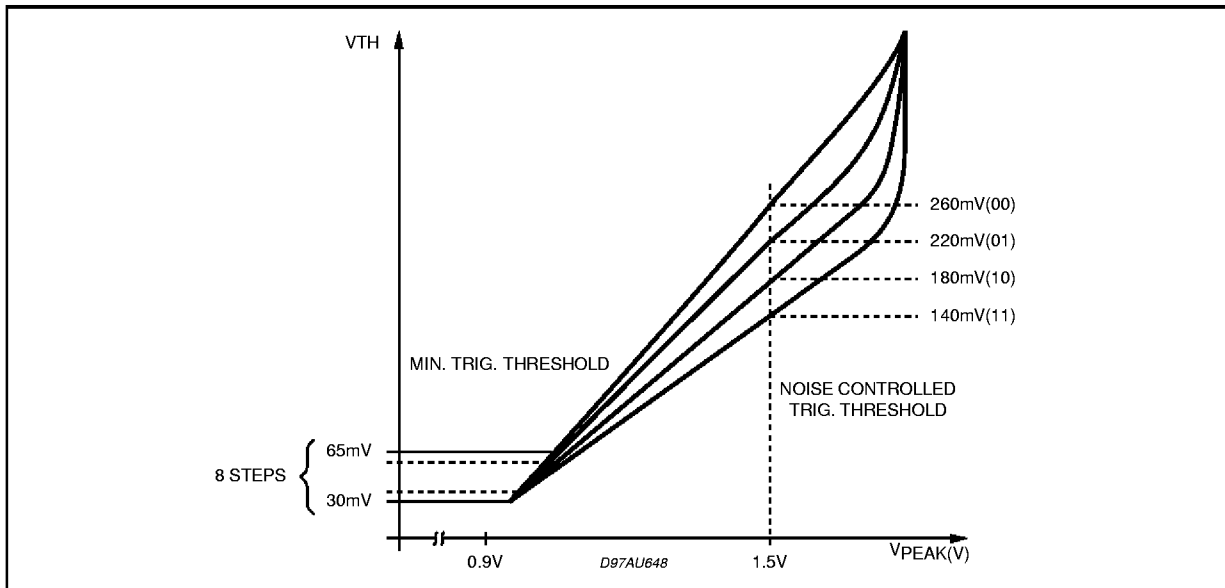

Figure 15. Deviation Controlled Trigger Adjustment

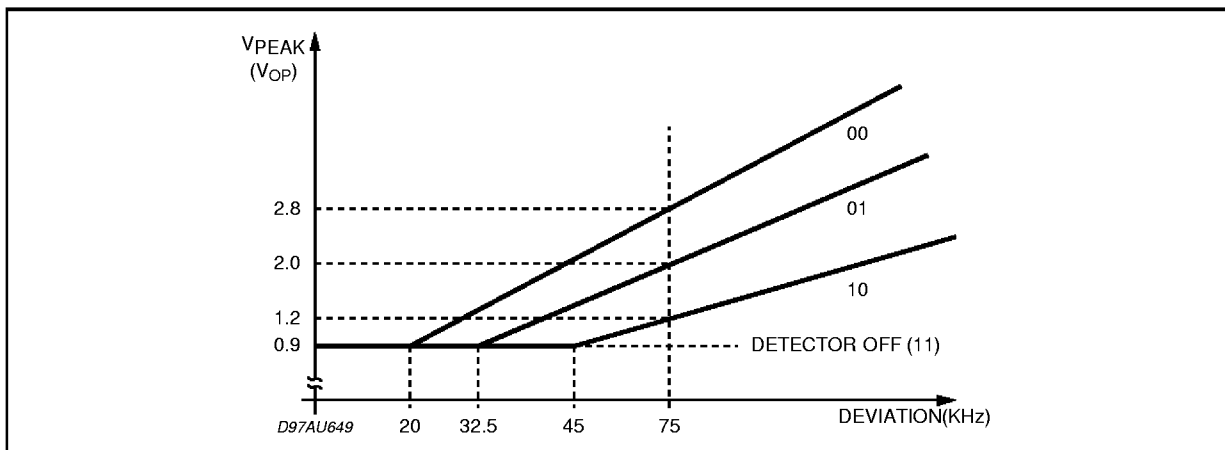
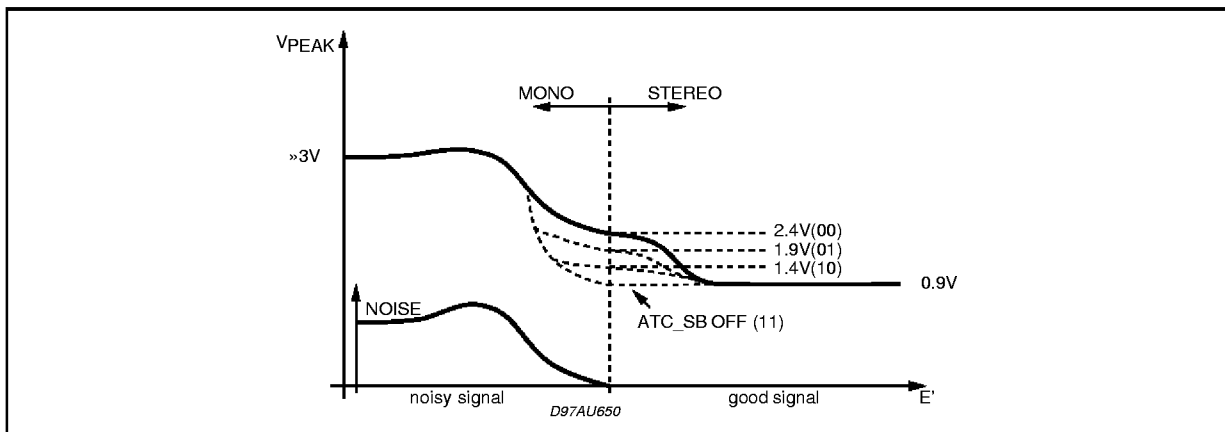

Figure 16. Fieldstrength Controlled Trigger Adjustment



MULTIPATH DETECTOR

- Internal 19kHz bandpass filter
- Programmable bandpass and rectifier gain
- Two pin solution fully independent usable for external programming
- Selectable internal influence on Stereoblend

ELECTRICAL CHARACTERISTICS (continued)

Symbol	Parameter	Test Condition	Min.	Typ.	Max.	Unit
f _{CMP}	Center frequency of Multipath-Bandpass	stereodecoder locked on pilot tone		19		KHz
G _{BPMP}	Bandpass Gain	bits D ₂ , D ₁ configuration byte = 00		6		dB
		bits D ₂ , D ₁ configuration byte = 01		16		dB
		bits D ₂ , D ₁ configuration byte = 10		12		dB
		bits D ₂ , D ₁ configuration byte = 11		18		dB
G _{RECTMP}	Reflection Gain	bits D ₇ , D ₆ configuration byte = 00		7.6		dB
		bits D ₇ , D ₆ configuration byte = 01		4.6		dB
		bits D ₇ , D ₆ configuration byte = 10		0		dB
I _{CHMP}	Rectifier Charge Current			1		μA
I _{DISMP}	Rectifier Discharge Current			1.5		mA

Figure 17. Block diagram of the stereodecoder

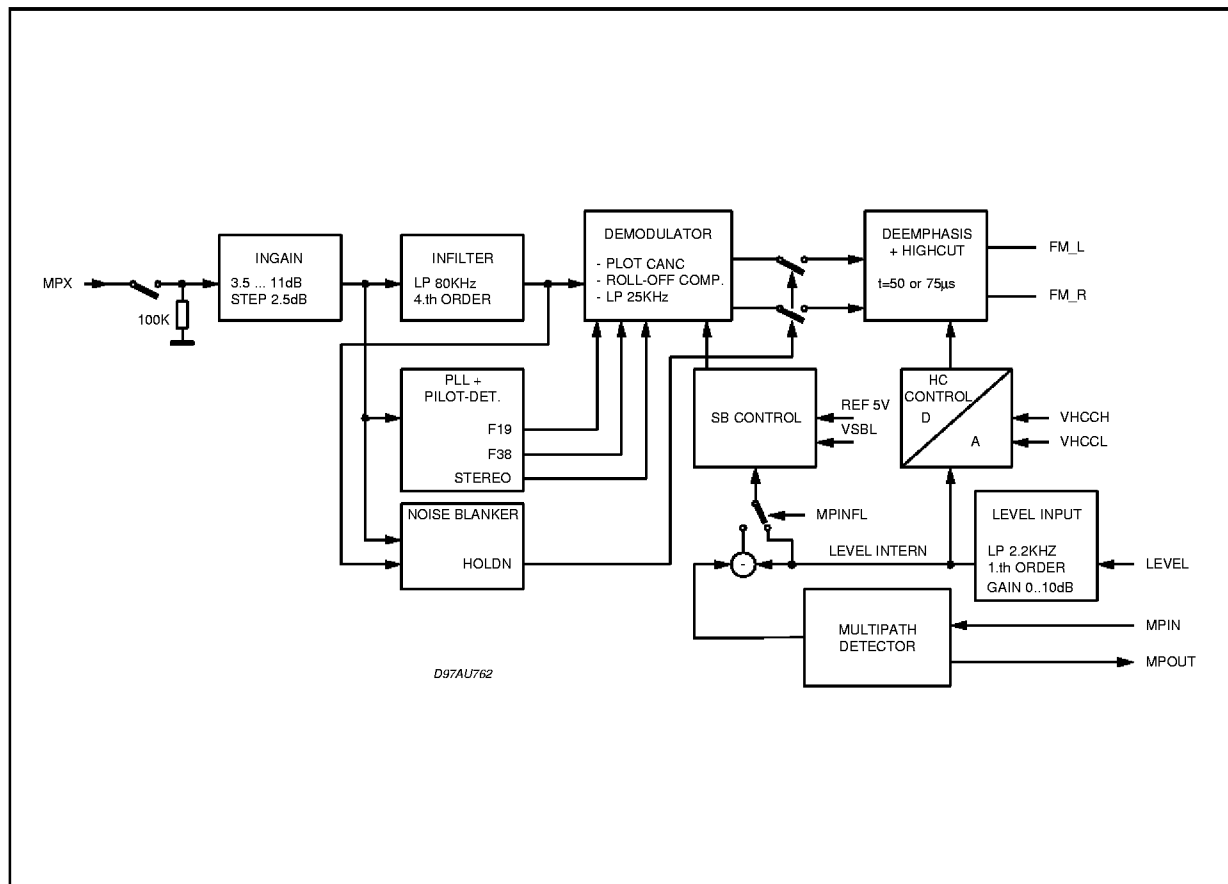

DESCRIPTION OF STEREODECODER

The stereodecoder part of the TDA7461 (see Fig. 17) contains all functions necessary to demodulate the MPX signal like pilot tone dependent MONO/STEREO switching as well as "stereoblend" and "highcut" functions.

Adaptations like programmable input gain, roll-off compensation, selectable deemphasis time constant and a programmable fieldstrength input allow to use different IF devices.

Stereodecoder Mute

The TDA7461 has a fast and easy to control RDS mute function which is a combination of the audioprocessor softmute and the high-ohmic mute of the stereodecoder. If the stereodecoder is selected and a softmute command is sent (or activated through the SM pin) the stereodecoder will be set automatically to the high-ohmic mute condition after the audio signal has been softmuted.

Hence a checking of alternate frequencies could be performed. To release the system from the mute condition simply the unmute command must be sent: the stereodecoder is unmuted immediately and the audioprocessor is softly unmuted. Fig. 18 shows the output signal V_o as well as the internal stereodecoder mute signal. This influence of Softmute on the stereodecoder mute can be switched off by setting bit 3 of the Softmute byte to "0". A stereodecoder mute command (bit 0, stereodecoder byte set to "1") will set the stereodecoder in any case independently to the high-ohmic mute state.

If any other source than the stereodecoder is selected the decoder remains muted and the MPX pin is connected to V_{ref} to avoid any discharge of the coupling capacitor through leakage currents.

Input Stages

The Ingain stage allows to adjust the MPX signal to a magnitude of about $1V_{rms}$ internally which is the recommended value. The 4.th order input filter has a corner frequency of 80kHz and is used to attenuatespikes and noise and acts as an anti-aliasing filter for the following switch capacitor filters.

Demodulator

In the demodulator block the left and the right channel are separated from the MPX signal. In this stage also the 19 kHz pilot tone is cancelled. For reaching a high channel separation the TDA7461 offers an I2C bus programmable roll-off adjustment which is able to compensate the low-

Figure 18. Signals during stereodecoder's softmute

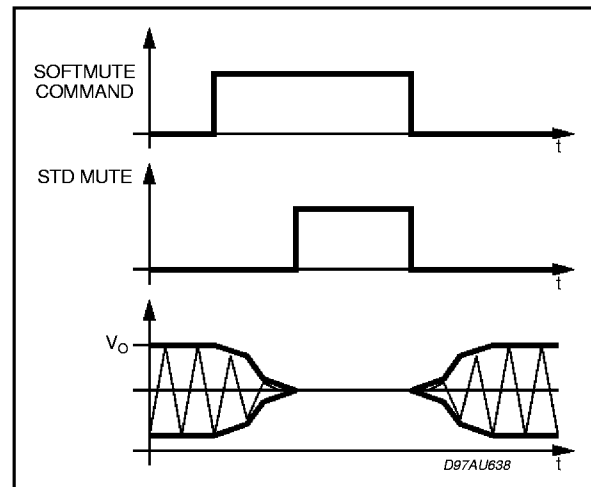

pass behaviour of the tuner section. If the tuner attenuation at 38kHz is in a range from 20.2% to 31% the TDA7461 needs no external network before the MPX pin. Within this range an adjustment to obtain at least 40dB channel separation is possible.

The bits for this adjustment are located together with the fieldstrength adjustment in one byte. This gives the possibility to perform an optimization step during the production of the carradio where the channel separation and the fieldstrength control are trimmed.

Deemphasis and Highcut.

The lowpass filter for the deemphasis allows to choose between a time constant of $50\mu s$ and $75\mu s$ (bit D7, Stereodecoder byte).

The highcut control range will be in both cases $t_{HC} = 2 \cdot t_{Deemp}$. Inside the highcut control range (between VHCH and VHCL) the LEVEL signal is converted into a 5 bit word which controls the lowpass time constant between $t_{Deemp} \dots 3 \cdot t_{Deemp}$. There by the resolution will remain always 5 bits independently of the absolute voltage range between the VHCH and VHCL values.

The highcut function can be switched off by I2C bus (bit D7, Fieldstrength byte set to "0").

PLL and Pilot Tone Detector

The PLL has the task to lock on the 19kHz pilot tone during a stereo transmission to allow a correct demodulation. The included detector enables the demodulation if the pilot tone reaches the selected pilot tone threshold V_{PTHST} . Two different thresholds are available. The detector output (signal STEREO, see block diagram) can be checked

by reading the status byte of the TDA7461 via I2C bus.

Fieldstrength Control

The fieldstrength input is used to control the high cut and the stereoblend function. In addition the signal can be also used to control the noise-blanker thresholds.

LEVEL Input and Gain

To suppress undesired high frequency modulation on the highcut and stereoblend function the LEVEL signal is lowpass filtered firstly. The filter is a combination of a 1st order RC lowpass at 53kHz (working as anti-aliasing filter) and a 1st-order switched capacitor lowpass at 2.2kHz. The second stage is a programmable gain stage to adapt the LEVEL signal internally to different IF.

The gain is widely programmable in 16 steps from 0dB to 10dB (step = 0.67dB). These 4 bits are located together with the Roll-Off bits in the "Stereodecoder Adjustment" byte to simplify a possible adaptation during the production of the carradio.

Stereoblend Control

The stereoblend control block converts the internal LEVEL voltage (LEVEL INTERN) into an demodulator compatible analog signal which is used to control the channel separation between 0dB and the maximum separation. Internally this control range has a fixed upper limit which is the internal reference voltage REF5V. The lower limit can be programmed to be 33%, 42%, 50% or 58% of REF5V (see fig. 20).

To adjust the external LEVEL voltage to the internal range two values must be defined: the LEVEL

Figure 19. Internal stereoblend characteristics

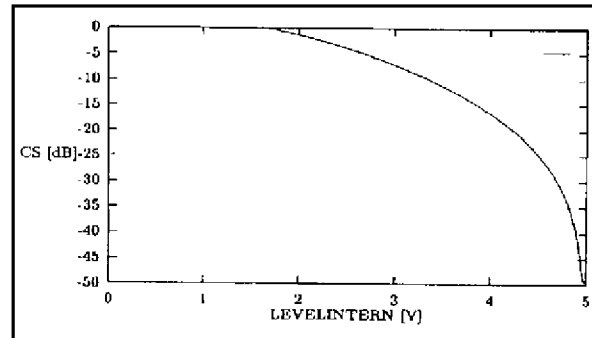

gain L_G and VSBL. To adjust the voltage where the full channel separation is reached (VST) the LEVEL gain L_G has to be defined. The following equation can be used to estimate the gain:

$$L_G = \frac{REF5V}{\text{Field strength voltage [STEREO]}}$$

The gain can be programmed through 4 bits in the "Stereodecoder-Adjustment" byte.

The MONO voltage VMO (0dB channel separation) can be chosen selecting 33, 42, 50 or 58% of REF5V.

All necessary internal reference voltages like REF5V are derived from a bandgap circuit. Therefore they have a temperature coefficient near zero. This is useful if the fieldstrength signal is also temperature compensated.

But most IF devices apply a LEVEL voltage with a TC of 3300ppm. The TDA7461 offers this TC for the reference voltages, too. The TC is selectable with bit D7 of the "stereodecoder adjustment" byte.

Figure 20. Relation between internal and external LEVEL voltage and setup of Stereoblend

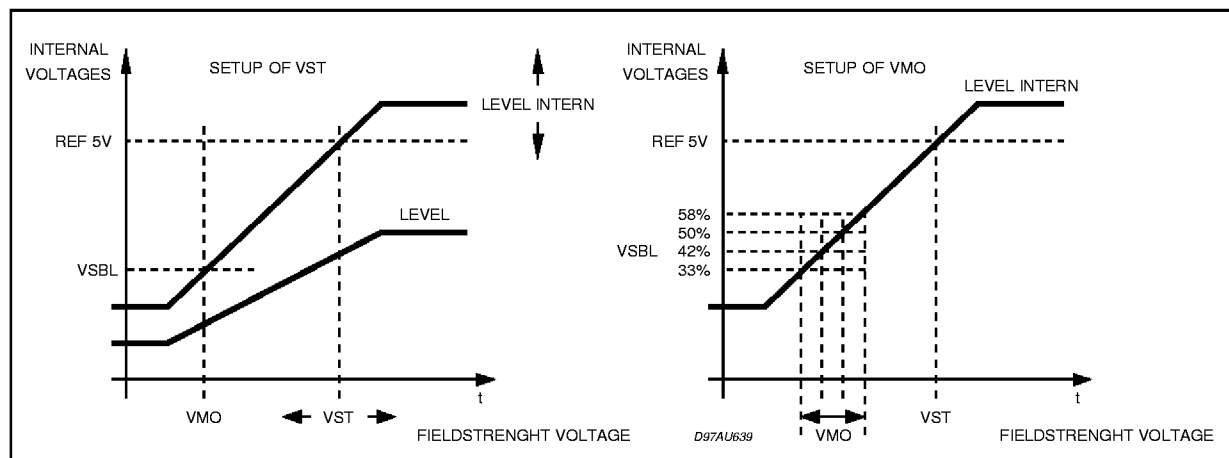

Highcut Control

The highcut control setup is similar to the stereoblend control setup : the starting point VHCH can be set with 2 bits to be 42, 50, 58 or 66% of REF5V whereas the range can be set to be 17 or 33% of VHCH (see fig. 21).

Figure 21. Highcut characteristics

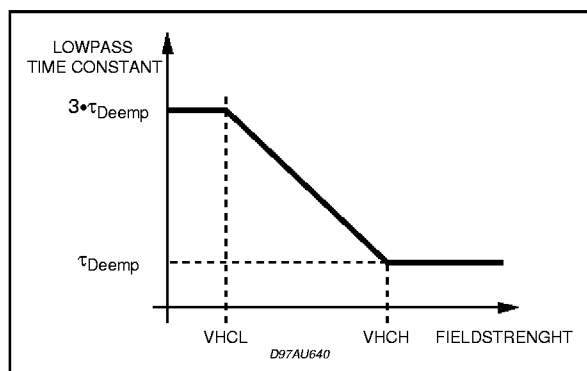

FUNCTIONAL DESCRIPTION OF THE NOISE-BLANKER

In the automotive environment the MPX signal is disturbed by spikes produced by the ignition and for example the wiper motor. The aim of the noiseblanker part is to cancel the audible influence of the spikes. Therefore the output of the stereodecoder is held at the actual voltage for 40µs.

In a first stage the spikes must be detected but to avoid a wrong triggering on high frequency (white) noise a complex trigger control is implemented. Behind the triggerstage a pulse former generates the "blanking" pulse. To avoid any crosstalk to the signalpath the noiseblanker is

supplied by his own biasing circuit.

Trigger Path

The incoming MPX signal is highpass filtered, amplified and rectified. This second order high-pass-filter has a corner frequency of 140kHz. The rectified signal, RECT, is lowpass filtered to generate a signal called PEAK. Also noise with a frequency 140kHz increases the PEAK voltage. The PEAK voltage is fed to a threshold generator, which adds to the PEAK voltage a DC dependent threshold VTH. Both signals, RECT and PEAK+VTH are fed to a comparator which triggers a re-triggerable monoflop. The monoflop's output activates the sample-and-hold circuits in the signalpath for 40µs.

The block diagram of the noiseblanker is given in fig.22.

Automatic Noise Controlled Threshold Adjustment (ATC)

There are mainly two independent possibilities for programming the trigger threshold:

- the low threshold in 8 steps (bits D0 to D2 of the noiseblanker byte)
- the noise adjusted threshold in 4 steps (bits D3 and D4 of the noiseblanker byte, see fig. 14).

The low threshold is active in combination with a good MPX signal without any noise; the PEAK voltage is less than 1V. The sensitivity in this operation is high.

If the MPX signal is noisy the PEAK voltage increases due to the higher noise, which is also rectified. With increasing of the PEAK voltage the trigger threshold increases, too. This particular gain is programmable in 4 steps (see fig. 14).

Figure 22. Block diagram of the noiseblanker

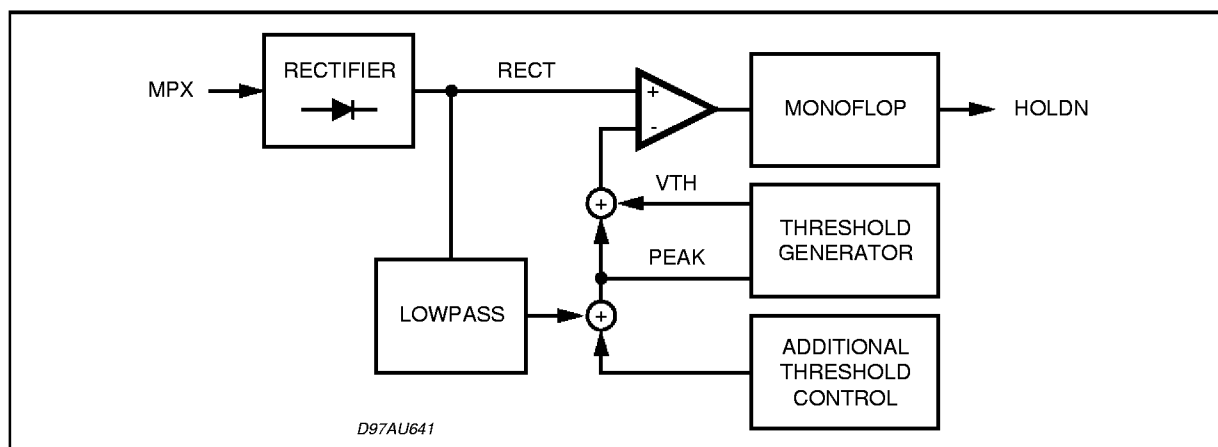

Automatic Threshold Control

Besides the noise controlled threshold adjustment there is an additional possibility for influencing the trigger threshold. It is depending on the stereoblend control.

The point where the MPX signal starts to become noisy is fixed by the RF part. Therefore also the starting point of the normal noise-controlled trigger adjustment is fixed (fig. 16). In some cases the behaviour of the noiseblanker can be improved by increasing the threshold even in a region of higher fieldstrength. Sometimes a wrong triggering occurs for the MPX signal often shows distortion in this range which can be avoided even if using a low threshold.

Because of the overlap of this range and the range of the stereo/mono transition it can be controlled by stereoblend. This threshold increase is programmable in 3 steps or switched off with bits D0 and D1 of the fieldstrength control byte.

Over Deviation Detector

If the system is tuned to stations with a high deviation the noiseblanker can trigger on the higher frequencies of the modulation. To avoid this wrong behaviour, which causes noise in the output signal, the noiseblanker offers a deviation dependent threshold adjustment.

By rectifying the MPX signal a further signal representing the actual deviation is obtained. It is

used to increase the PEAK voltage. Offset and gain of this circuit are programmable in 3 steps with the bits D6 and D7 of the stereodecoder byte (the first step turns off the detector, see fig. 15).

FUNCTIONAL DESCRIPTION OF THE MULTIPATH DETECTOR

Using the internal detector the audible effects of a multipath condition can be minimized. A multipath condition is detected by rectifying the 19kHz spectrum in the fieldstrength signal.

Selecting the "internal influence" in the configuration byte, the channel separation is automatically reduced during a multipath condition according to the voltage appearing at the MPOUT pin.

To obtain a optimal performance an adaptation is necessary. Therefore the gain of the 19kHz bandpass is programmable in four steps as well as the rectifier gain. The attack and decay times can be set by the external capacitor value.

TEST MODE

During the test mode which can be activated by setting bit D0 of the testing byte and bit D5 of the subaddress byte to "1" several internal signals are available at the CASSR pin. During this mode the input resistance of 100kOhm is disconnected from the pin. The internal signals available are shown in the software specification.

Figure 23. Block diagram of the Multipath Detector

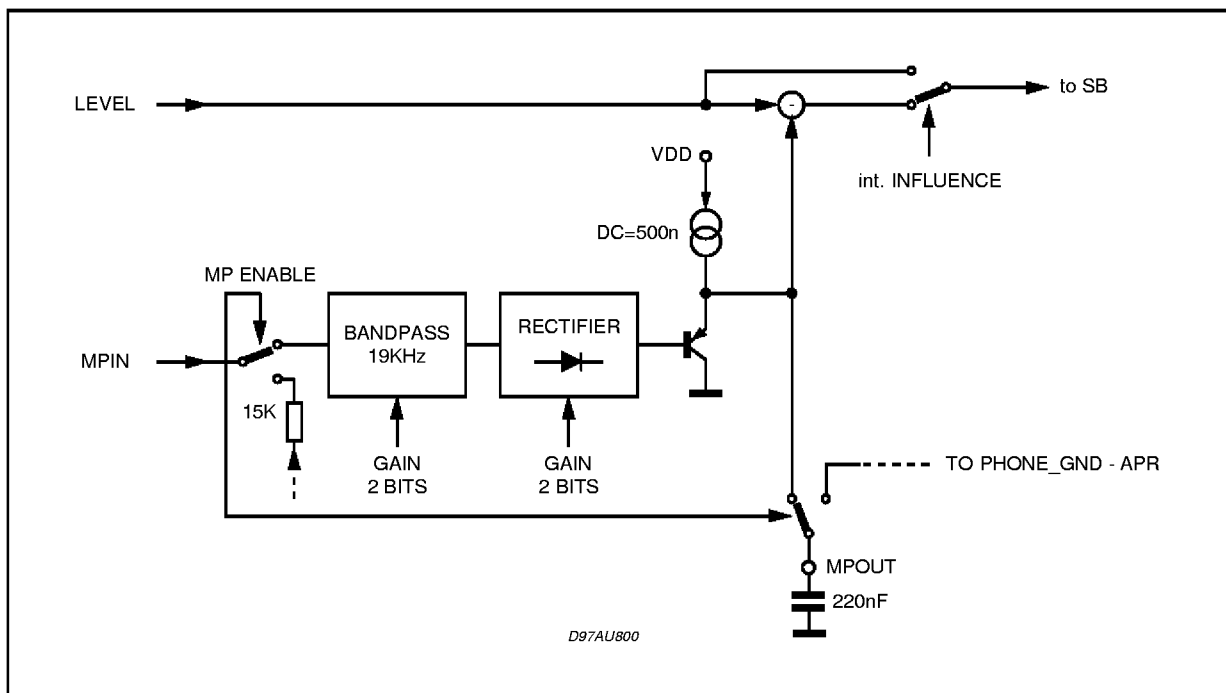

Figure 24. Application Example 1

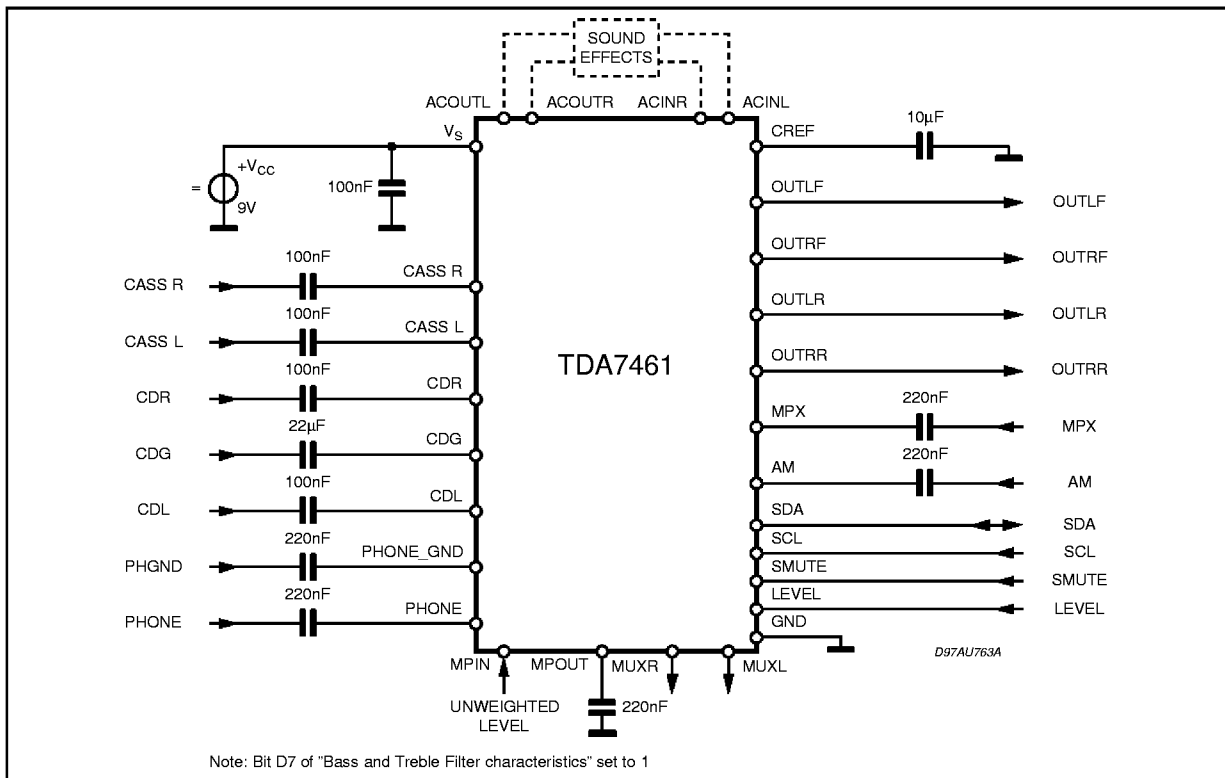
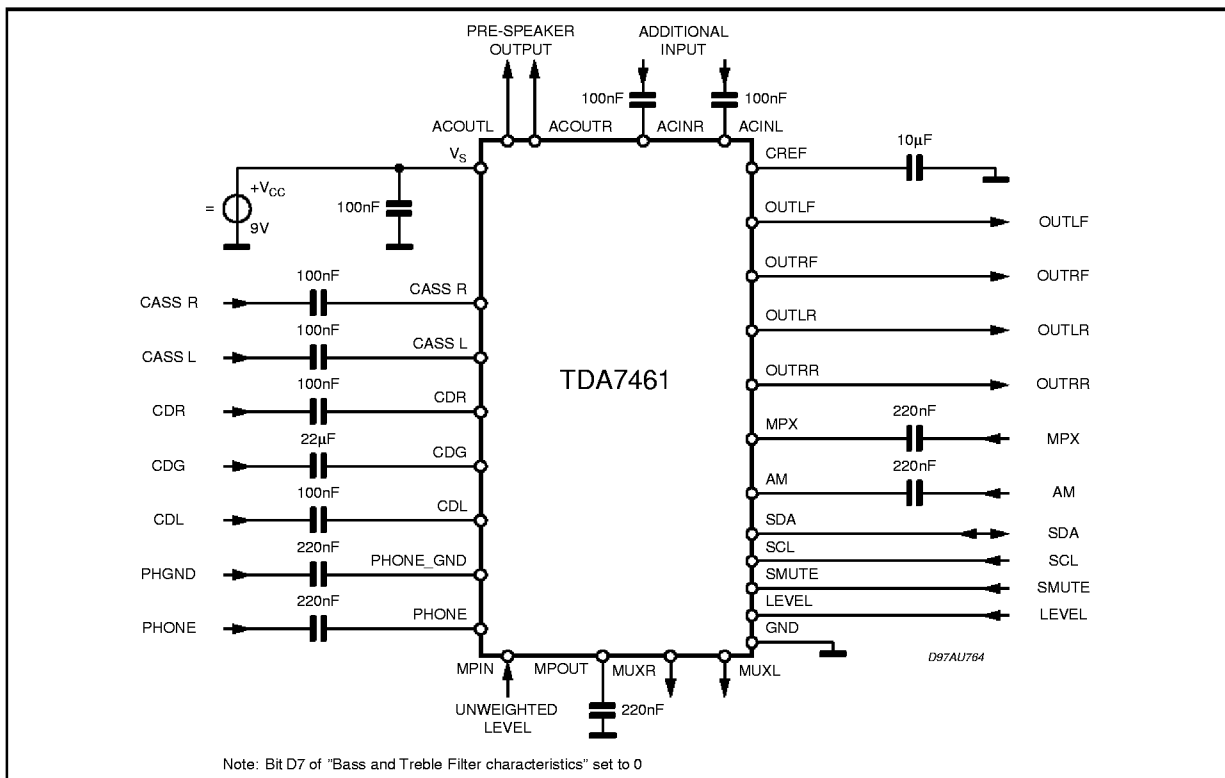

Figure 25. Application Example 2



I²C BUS INTERFACE DESCRIPTION

Interface Protocol

The interface protocol comprises:

- a start condition (S)
- a chip address byte (the LSB bit determines read

/ write transmission)

- a subaddress byte
- a sequence of data (N-bytes + acknowledge)
- a stop condition (P)

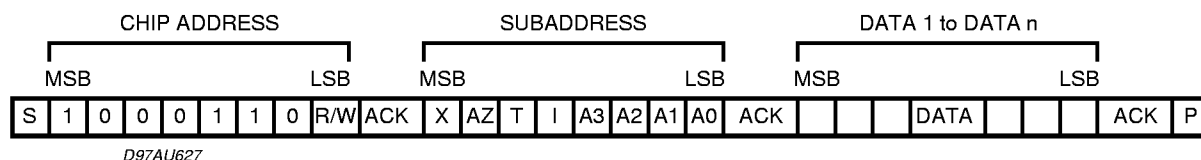

S = Start

ACK = Acknowledge

AZ = AutoZero-Remain

T = Testing

I = Autoincrement

P = Stop

MAX CLOCK SPEED 500kbits/s

The transmitted data is automatically updated after each ACK.

Transmission can be repeated without new chip address.

Auto increment

If bit I in the subaddress byte is set to "1", the autoincrement of the subaddress is enabled.

TRANSMITTED DATA (send mode)

MSB						LSB	
X	X	X	X	ST	SM	X	X

SM = Soft mute activated

ST = Stereo

X = Not Used

SUBADDRESS (receive mode)

MSB				LSB				FUNCTION
X	AZ	T	I	A3	A2	A1	A0	
				0	0	0	0	Input selector
				0	0	0	1	Loudness / Auto-Zero
				0	0	1	0	Volume
				0	0	1	1	Softmute / Beep
				0	1	0	0	Bass / Treble Attenuator
				0	1	0	1	Bass / Treble Configuration
				0	1	1	0	Speaker attenuator LF
				0	1	1	1	Speaker attenuator LR
				1	0	0	0	Speaker attenuator RF
				1	0	0	1	Speaker attenuator RR / Blanktime adjust
				1	0	1	0	Stereodecoder
				1	0	1	1	Noiseblanker
				1	1	0	0	Fieldstrength Control
				1	1	0	1	Configuration
				1	1	1	0	Stereodecoder Adjustment
				1	1	1	1	Testing

T = Testmode

I = Autoincrement

AZ = Auto Zero Remain

X = not used

DATA BYTE SPECIFICATION

Input Selector

MSB							LSB	FUNCTION
D7	D6	D5	D4	D3	D2	D1	D0	
					0	0	0	Source Selector
					0	0	1	CD
					0	1	0	Cassette
					0	1	1	Phone
					1	0	0	AM
					1	0	1	Stereo Decoder
					1	1	0	Input FM
					1	1	1	Mute
								AC inputs
				0				CD Mode
				1				CD Full-differential
								CD Quasi-diff
			1		0	1	1	AM/FM Mode
			0		0	1	1	AM mono
			0		1	0	0	AM stereo
			1		1	0	0	AM through Stereodecoder
								FM- Stereodecoder
0	0	0						In-Gain
0	0	1						14dB
:	:	:						12dB
1	1	0						:
1	1	1						2 dB
								0 dB

For example to select the CD input in quasi-differential mode with gain of 8dB the Data Byte is: 0/01111000

Loudness

MSB							LSB	LOUDNESS
D7	D6	D5	D4	D3	D2	D1	D0	
				0	0	0	0	Attenuation
				0	0	0	1	0dB
				:	:	:	:	-1dB
				1	1	1	0	-14dB
				1	1	1	1	-15dB
			0					Filter
			1					on
								off (flat)
		0						Center Frequency
		1						200Hz
								400Hz
	0							Loudness Q
	1							low (1 st order)
								normal (2 nd order)
1								must be "1"

Note: The attenuation is specified at high frequencies. Around the center frequency the value is different depending on the programmed attenuation (see Loudness frequency response).

Mute, Beep and Mixing

MSB							LSB	MUTE/BEEP/MIXING
D7	D6	D5	D4	D3	D2	D1	D0	
							0	Mute Enable Softmute Disable Softmute Mute time =0.48 ms Mute time =0.96 ms Mute time =40.4 ms Mute time =324 ms Stereo Decoder Softmute Influence = off Stereo Decoder Softmute Influence = on
					0	0	1	
					0	1	0	
				0	1	1	1	
			0					Beep Beep Frequency = 600Hz Beep Frequency = 1.2KHz
			1					
0	0	0						Mixing Mix-Source = Beep Mix-Source = Phone Full Mix Signal Source -12dB + Mix-Signal -2.5dB Source -6dB + Mix-Signal -6dB Full Source
0	1	1						
1	0							
1	1							

Note: for more information to the Stereodecoder-Softmute-Influence please refer to the stereodecoder description.

Volume

MSB							LSB	ATTENUATION	
D7	D6	D5	D4	D3	D2	D1	D0		
								Gain/Attenuation +32dB +31dB : : +20dB +19dB +18dB : : +1dB 0dB - 1dB : : -78dB -79dB	
	0	0	0	0	0	0	0		
	0	0	0	0	0	0	1		
	:	:	:	:	:	:	:		
	0	0	0	1	1	0	0		
	0	0	0	1	1	0	1		
	0	0	0	1	1	1	0		
	:	:	:	:	:	:	:		
	0	0	1	1	1	1	1		
	0	1	0	0	0	0	0		
	0	1	0	0	0	0	1		
	:	:	:	:	:	:	:		
	1	1	0	1	1	1	0		
	1	1	0	1	1	1	1		
0									Softstep Softstep Volume = off Softstep Volume = on
1									

Note: It is not recommended to use a gain more than 20dB for system performance reason. In general, the max. gain should be limited by software to the maximum value, which is needed for the system.



Bass & Treble Attenuation

MSB							LSB		BASS & TREBLE ATTENUATION
D7	D6	D5	D4	D3	D2	D1	D0		
				0	0	0	0	Treble Steps	
				0	0	0	1	-14dB	
				:	:	:	:	-12dB	
				0	1	1	0	:	
				0	1	1	1	-2dB	
				1	1	1	1	0dB	
				1	1	1	0	0dB	
				:	:	:	:	+2dB	
				1	0	0	1	:	
				1	0	0	0	+12dB	
								+14dB	
0	0	0	0					Bass Steps	
0	0	0	1					-14dB	
:	:	:	:					-12dB	
0	1	1	0					:	
0	1	1	1					-2dB	
1	1	1	1					0dB	
1	1	1	0					0dB	
:	:	:	:					+2dB	
1	0	0	1					:	
1	0	0	0					+12dB	
								+14dB	

For example 12dB Treble and -8dB Bass give the following DATA BYTE : 0 0 1 1 1 0 0 1.

Bass & Treble Filter Characteristics

MSB							LSB		BASS & TREBLE FILTER
D7	D6	D5	D4	D3	D2	D1	D0		
						0	0	Treble	
						0	1	Center Frequency = 10 KHz	
						1	0	Center Frequency = 12.5 KHz	
						1	1	Center Frequency = 15 KHz	
								Center Frequency = 17.5 KHz	
				0	0			Bass	
				0	1			Center Frequency = 60 Hz	
				1	0			Center Frequency = 70 Hz	
				1	1			Center Frequency = 80 Hz	
				1	1			Center Frequency = 100Hz	
		1	1					Center Frequency = 150Hz	
		0	0					Quality factor = 1	
		0	1					Quality factor = 1.25	
		1	0					Quality factor = 1.5	
		1	1					Quality factor = 2	
	0							DC-Gain = 0dB	
	1							DC-Gain = ± 4.4 dB	
0								AC Coupling (*)	
1								For External Connection	
								Internally connected	

For example Treble center frequency = 15kHz, Bass center frequency = 100Hz, Bass Q = 1 and DC = 0dB give the following DATA BYTE: 1 0 0 0 1 1 1 0

(*) For deeper information see application examples fig. 24 and fig. 25.

Speaker Attenuation (LF, LR, RF, RR)

MSB							LSB	
D7	D6	D5	D4	D3	D2	D1	D0	
		0	0	0	0	0	0	Attenuation 0dB
		0	0	0	0	0	1	-1dB
		:	:	:	:	:	:	:
		0	1	0	1	1	1	-23dB
		0	1	1	0	0	0	-24.5dB
		0	1	1	0	0	1	-26dB
		0	1	1	0	1	0	-28dB
		0	1	1	0	1	1	-30
		0	1	1	1	0	0	-32dB
		0	1	1	1	0	1	-35dB
		0	1	1	1	1	0	-40dB
		0	1	1	1	1	1	-50dB
1	1	1						Speaker Mute Must be "1" (except RR speaker; see below)
0	0							Blank Time adj. (only at RR speaker) 38µs
0	1							25.5µs
1	0							32µs
1	1							22µs
	0							Output selector for pins 15 and 16. Stereodecoder output selected
	1							Input multiplexer output selected

Stereodecoder

MSB							LSB		FUNCTION
D7	D6	D5	D4	D3	D2	D1	D0		
							0	STD Unmuted	
							1	STD Muted	
					0	0		IN-Gain 11dB	
					0	1		IN-Gain 8.5dB	
					1	0		IN-Gain 6dB	
					1	1		IN-Gain 3.5dB	
				1				must be "1"	
		1	0					Forced MONO	
		1	1					MONO/STEREO switch automatically	
	0							Pilot Threshold HIGH	
	1							Pilot Threshold LOW	
0								Deemphasis 50 μ s	
1								Deemphasis 75 μ s	

Noiseblinker

MSB							LSB		FUNCTION
D7	D6	D5	D4	D3	D2	D1	D0		
					0	0	0	Low Threshold 65mV	
					0	0	1	Low Threshold 60mV	
					0	1	0	Low Threshold 55mV	
					0	1	1	Low Threshold 50mV	
					1	0	0	Low Threshold 45mV	
					1	0	1	Low Threshold 40mV	
					1	1	0	Low Threshold 35mV	
					1	1	1	Low Threshold 30mV	
			0	0				Noise Controlled Threshold 320mV	
			0	1				Noise Controlled Threshold 260mV	
			1	0				Noise Controlled Threshold 200mV	
			1	1				Noise Controlled Threshold 140mV	
		0						Noise blanker OFF	
		1						Noise blanker ON	
0	0							Over deviation Adjust 2.8V	
0	1							Over deviation Adjust 2.0V	
1	0							Over deviation Adjust 1.2V	
1	1							Over deviation Detector OFF	

Fieldstrength Control

MSB							LSB		FUNCTION
D7	D6	D5	D4	D3	D2	D1	D0		
						0 0 1 1	0 1 0 1	Noiseblanker Field strength Adj 2.3V Noiseblanker Field strength Adj 1.8V Noiseblanker Field strength Adj 1.3V Noiseblanker Field strength Adj OFF	
				0 0 1 1	0 1 0 1			VSBL at 33% REF 5V VSBL at 42% REF 5V VSBL at 50% REF 5V VSBL at 58% REF 5V	
		0 0 1 1	0 1 0 1					VHCH at 42% REF 5V VHCH at 50% REF 5V VHCH at 58% REF 5V VHCH at 66% REF 5V	
	1 0							VHCL at 17% VHCH VHCL at 33% VHCH	
0 1								High cut OFF High cut ON	

Configuration

MSB							LSB		FUNCTION
D7	D6	D5	D4	D3	D2	D1	D0		
						0 0 1 1	0 1 0 1	Noise Rectifier Discharge Resistor R = infinite R = 56kΩ R = 33kΩ R = 18kΩ	
				0 0 1 1	0 1 0 1			Multipath Detector Bandpass Gain 6dB 16dB 12dB 18dB	
			0 1					Multipath Detector Internal influence ON OFF	
		1						Must be "1"	
0 0 1 1	0 1 0 1							Multipath Detector Reflection Gain Gain = 7.6dB Gain = 4.6dB Gain = 0dB OFF	

Stereodecoder Adjustment

MSB							LSB	FUNCTION
D7	D6	D5	D4	D3	D2	D1	D0	
					0 0 0 : 1 : 1	0 0 1 : 0 : 1	0 1 0 : 0 : 1	Roll-Off Compensation not allowed 20.2% 21.9% : 25.5% : 31.0%
	0 0 0 : 1	0 0 0 : 1	0 0 1 : 1	0 1 0 : 1				LEVEL Gain 0dB 0.66dB 1.33dB : 10dB
0 1								Temperature compensation at LEVEL input TC = 0 TC = 16.7mV/K (3300ppm)

Testing

MSB							LSB	FUNCTION
D7	D6	D5	D4	D3	D2	D1	D0	
							0 1	Stereodecoder test signals OFF Test signals enabled if bit D5 of the subaddress (test mode bit) is set to "1", too
						0 1		External Clock Internal Clock
		0 0 0 0 0 0 0 0 1 1 1 1 1 1 1 1	0 0 0 0 1 1 1 0 0 0 1 1 1 1 1	0 0 1 1 0 1 1 0 0 0 1 1 0 0 1	0 1 0 1 0 1 1 0 0 0 1 0 0 0 1			Testsignals at CASS_R VHCCH Level intern Pilot magnitude VCOCON; VCO Control Voltage Pilot threshold HOLDN NB threshold F228 VHCCL VSBL not used not used PEAK not used REF5V not used
	0 1							VCO OFF ON
0 1								Audio processor test mode only if bit D5 of the subaddress (test mode bit) is set to "1" OFF

Note : This byte is used for testing or evaluation purposes only and must not be set to other values than the default "1111110" in the application!

SO28 PACKAGE MECHANICAL DATA

DIM.	mm			inch		
	MIN.	TYP.	MAX.	MIN.	TYP.	MAX.
A			2.65			0.104
a1	0.1		0.3	0.004		0.012
b	0.35		0.49	0.014		0.019
b1	0.23		0.32	0.009		0.013
C		0.5			0.020	
c1	45° (typ.)					
D	17.7		18.1	0.697		0.713
E	10		10.65	0.394		0.419
e		1.27			0.050	
e3		16.51			0.65	
F	7.4		7.6	0.291		0.299
L	0.4		1.27	0.016		0.050
S	8° (max.)					

