

STEREO HEADPHONE AMPLIFIER (3V USE)

The TA7688F is a stereo headphone power amplifier IC designed for portable cassette player applications.

FEATURES

- Small installed area and few external parts
- Low supply current : $I_{CCQ} = 7\text{mA}$ (Typ.) at 3V
- Built-in a ripple filter
- Built-in a power amplifier mute
- Built-in a power off circuit
- Operating supply voltage range : $V_{CC}(\text{opr}) = 1.8\sim 5\text{V}$
- Recommended supply voltage : $V_{CC} = 3\text{V}$
- The standard model is TA7688F (SO)

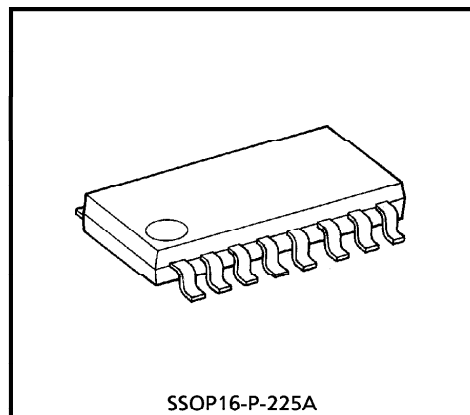

Weight : 0.14g (Typ.)

BLOCK DIAGRAM

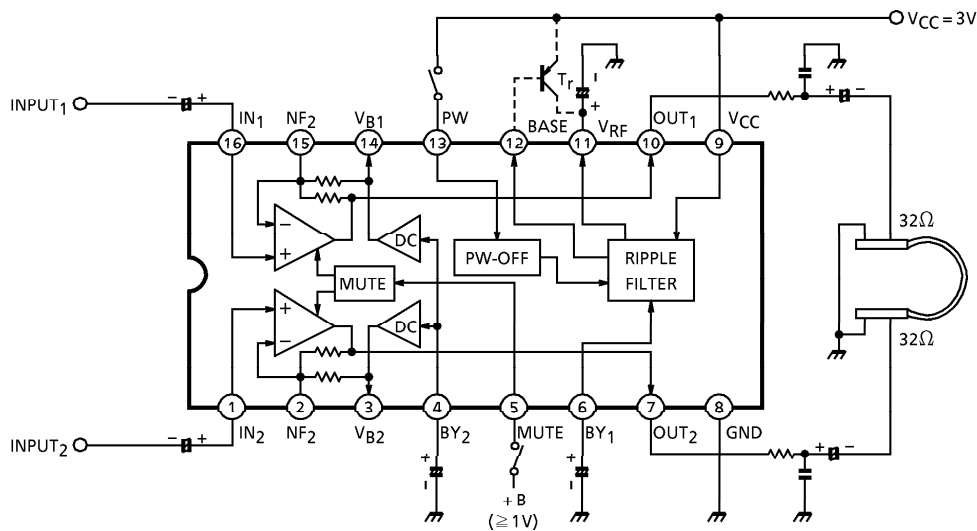

Dotted Line is an additional circuit to boost the stabilized current. (Option)

© The information contained herein is presented only as a guide for the applications of our products. No responsibility is assumed by TOSHIBA CORPORATION for any infringements of intellectual property or other rights of the third parties which may result from its use. No license is granted by implication or otherwise under any intellectual property or other rights of TOSHIBA CORPORATION or others.

© These TOSHIBA products are intended for use in general commercial applications (office equipment, communication equipment, measuring equipment, domestic appliances, etc.). please make sure that you consult with us before you use these TOSHIBA products in equipment which requires extraordinarily high quality and/or reliability, and in equipment which may involve life threatening or critical application, including but not limited to such uses as atomic energy control, airplane or spaceship instrumentation, traffic signals, medical instrumentation, combustion control, all types of safety devices, etc. TOSHIBA cannot accept and hereby disclaims liability for any damage which may occur in case the TOSHIBA products are used in such equipment or applications without prior consultation with TOSHIBA.

①

TA7688F - 1

1996 - 4 - 22

TOSHIBA CORPORATION

APPLICATION NOTE

1. Voltage gain adjustment

The closed loop Voltage gain G_V is determined by the ratio of R_1 and R_2 shown in Fig.1.

$$G_V = 20 \log \frac{R_1 + R_2}{R_2} = 32\text{dB}$$

But the actual value is 30.5dB because of influence of the other circuit.

Fig.2 shows the application circuit of higher or lower gain than recommended one.

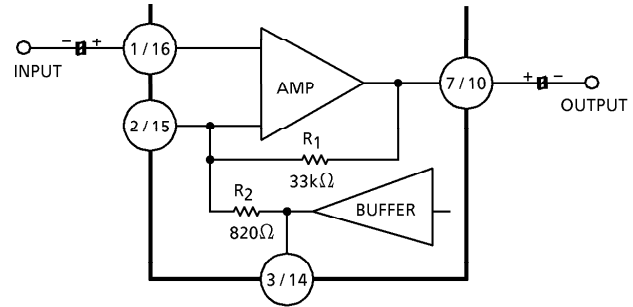

Fig.1

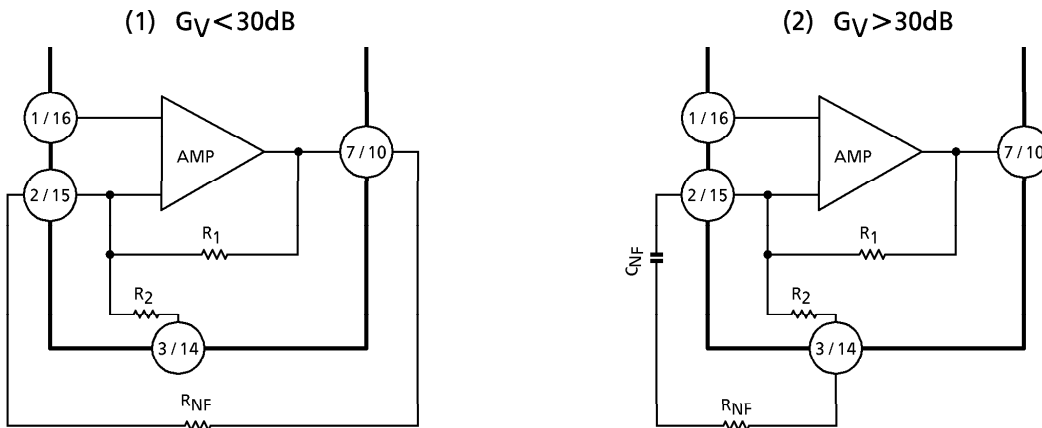

Fig.2

In the case of $G_V < 30\text{dB}$, it happens to oscillate by phase delay at high frequency.

So this IC is not available at $G_V < 30\text{dB}$. In the case of $G_V > 30\text{dB}$, input offset is amplified, so that output DC voltage differs from center voltage. The unsymmetrical clipping wave is prevented by inserting capacitor C_{NF} .

Therefore this IC is available at $G_V > 30\text{dB}$ by using C_{NF} .

It is recommended to check pop noise based on C_{NF} .

2. Muting

Muting operates when the voltage is applied to pin 5 or the current is flowed into pin 5.

Supply current is about half at muting ON.

It is necessary that muting drive current I_{MUTE} is less than $150\mu A$.

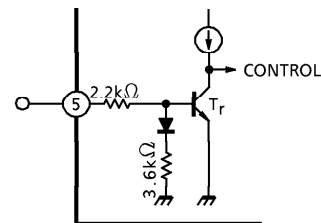

Fig.3

3. Oscillation precaution

(1) Oscillation preventing capacitor between output pin and GND is recommended to use capacitor with less temperature drift.

So suitable capacitor is not celamic or electrolytic capacitor, but tantalum or polyester film capacitor.

When protector resistor 3.9Ω is rejected, output power increases.

In this case, it is necessary to insert 3.9Ω as shown in Fig.4.

When $R_L = 0$, output current is very large in the circuit.

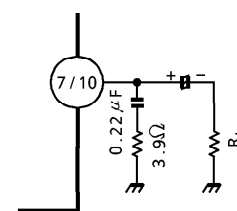

Fig.4

(2) It is necessary to use tantalum capacitor at Pin 11 ($22\mu F$).

(3) Decoupling capacitor C_{10} is necessary to be near the pin 9.

4. Radiation precaution

Because of wide band (about 200kHz), the radiation from the amplifier degrade S/N at radio. As shown in Fig.5, it recommended to limit the band by C and R.

In this case, phase compensation check is necessary.

When $C = 100pF$, $R = 15k\Omega$, f_{HC} is 30~50kHz.

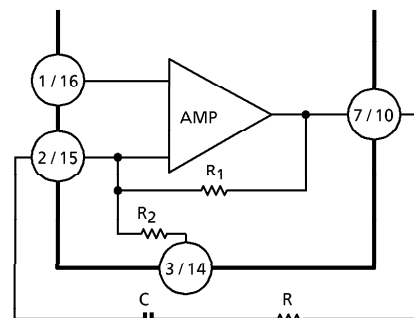

Fig.5

MAXIMUM RATINGS ($T_a = 25^\circ C$)

CHARACTERISTIC	SYMBOL	RATING	UNIT
Supply Voltage	V_{CC}	7	V
Output Current	I_O	160 / ch	mA
Filter Output Current	I_R	10	mA
Power Dissipation (Note)	P_D	350	mW
Operating Temperature	T_{opr}	-25~75	$^\circ C$
Storage Temperature	T_{stg}	-55~150	$^\circ C$

Note : Derated above $T_a = 25^\circ C$ in the proportion of $2.8mW / ^\circ C$.

ELECTRICAL CHARACTERISTICS

1. AC characteristics (Unless otherwise specified, $T_a = 25^\circ\text{C}$, $V_{CC} = 3\text{V}$, $R_g = 600\Omega$, $f = 1\text{kHz}$)
 $R_H = 3.9\Omega$, $R_L = 32\Omega$

CHARACTERISTIC		SYMBOL	TEST CIRCUIT	TEST CONDITION	MIN.	TYP.	MAX.	UNIT
Quiescent Current		$I_{CCQ(1)}$	—	$V_{in} = 0$	—	7	12	mA
		$I_{CCQ(2)}$	—	$V_{in} = 0$, $SW_2 : \text{OFF}$	—	1	10	μA
Output Power		$P_O(1)$	—	THD = 10%	20	27	—	mW
		$P_O(2)$	—	$R_L = 16\Omega$, THD = 10%	—	38	—	
Total Harmonic Distortion		THD	—	$P_O = 10\text{mW} / \text{ch}$	—	0.12	1.0	%
Closed Loop Voltage Gain		G_V	—	$V_{in} = -42\text{dBV}$	28.5	30.5	32.5	dB
Channel Balance		ΔG_V	—	$V_{in} = -42\text{dBV}$	—	0	± 1	dB
Cross Talk		CT	—	$V_O = -2\text{dBV}$, $\text{ch1} \leftrightarrow \text{ch2}$	45	65	—	dB
Ripple Rejection	Headphone AMP	RR (1)	—	$f_r = 1\text{kHz}$, $V_r = -22\text{dBV}$	30	45	—	dB
	Ripple Filter	RR (2)	—	$f_r = 100\text{Hz}$, $V_r = -22\text{dBV}$	—	40	—	dB
Output Noise Voltage		V_{no}	—	BPF = 20Hz~20kHz	—	0.06	0.2	mV_{rms}
Input Resistance		R_{IN}	—	$f = 1\text{kHz}$	15	20	25	$\text{k}\Omega$
Ripple Filter Output Voltage		$V_{RF(1)}$	—	$V_{CC} = 2\text{V}$, $I_{RF} = 10\text{mA}$	1.45	1.6	—	V
		$V_{RF(2)}$		$I_{RF} = 10\text{mA}$	2.1	2.3	2.5	
		$V_{RF(3)}$		$V_{CC} = 4.5\text{V}$, $I_{RF} = 10\text{mA}$	—	3.4	—	
Muting Attenuation		ATT	—	$V_{MUTE} = 3\text{V}$ (0dB = 240 mV_{rms})	60	80	—	dB
Muting Input Voltage		V_{MUTE}	—	ATT $\geq 50\text{dB}$ (0dB = 240 mV_{rms})	—	0.7	1.0	V
Muting Input Current		I_{MUTE}	—	ATT $\geq 50\text{dB}$ (0dB = 240 mV_{rms})	—	35	—	μA
Ripple Filter Current		I_B	—	—	—	0.05	—	mA

2. DC characteristics

($T_a = 25^\circ\text{C}$, $V_{CC} = 3\text{V}$, Terminal voltage at no signal)

ITEM	SYMBOL	RATING	UNIT
Terminal 1 (IN ₂)	V_1	1.5	V
2 (NF ₂)	V_2	1.5	V
3 (V _{B2})	V_3	1.5	V
4 (BYPASS ₂)	V_4	1.5	V
5 (MUTE)	V_5	0	V
6 (BYPASS ₁)	V_6	2.2	V
7 (OUT ₂)	V_7	1.5	V
8 (GND)	V_8	0	V
9 (V _{CC})	V_9	3.0	V
10 (OUT ₁)	V_{10}	1.5	V
11 (V _{RF})	V_{11}	2.3	V
12 (BASE)	V_{12}	2.2	V
13 (PW ON/OFF)	V_{13}	3.0	V
14 (V _{B1})	V_{14}	1.5	V
15 (NF ₁)	V_{15}	1.5	V
16 (IN ₁)	V_{16}	1.5	V

TEST CIRCUIT

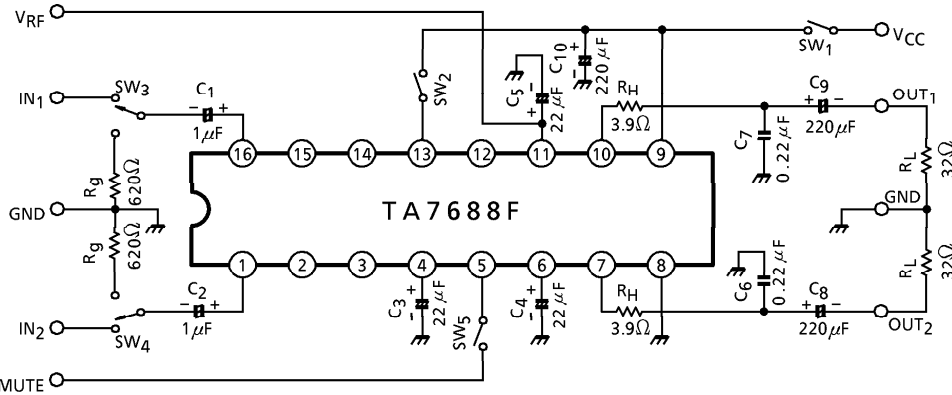

Note : R_H : Protection resistance
 C_6 & C_7 : Tantalum capacitor or polyester film capacitor
 C_5 : Tantalum capacitor

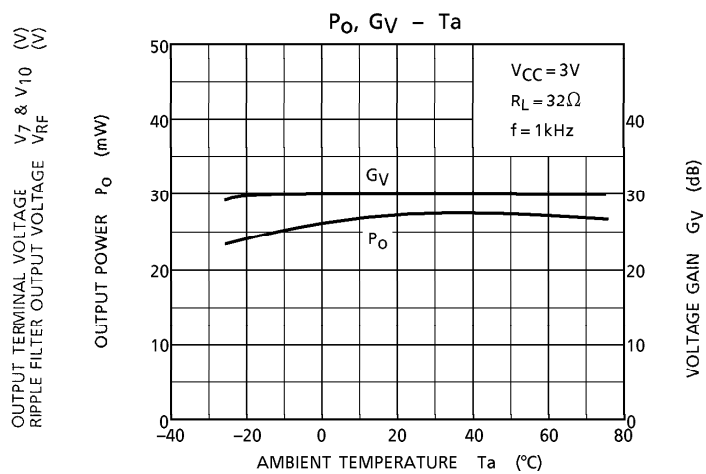
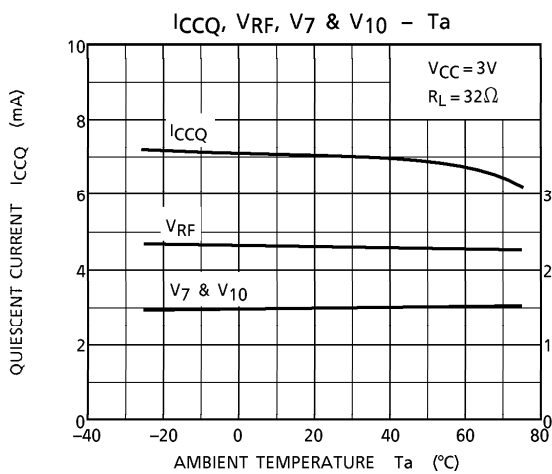
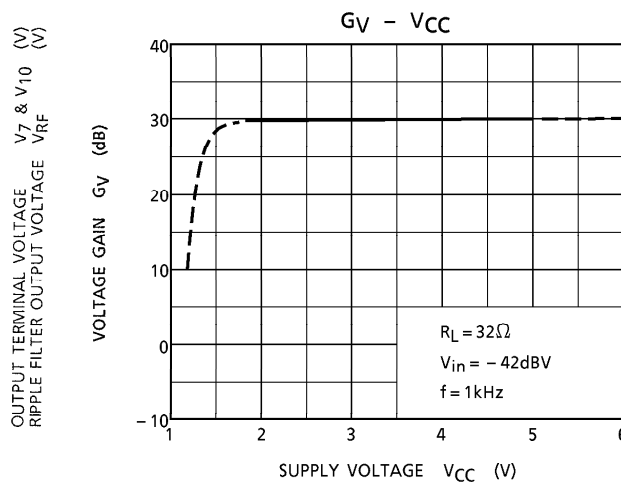
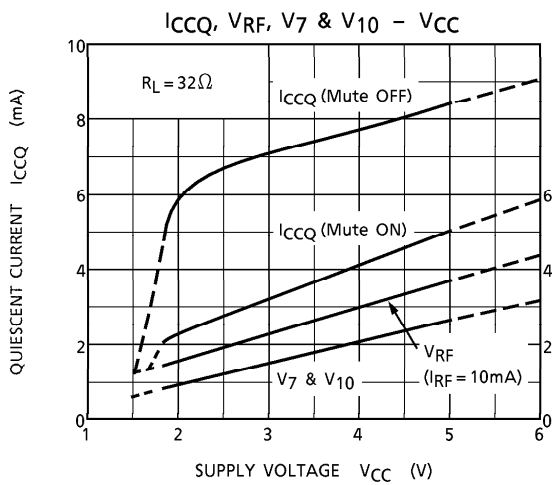

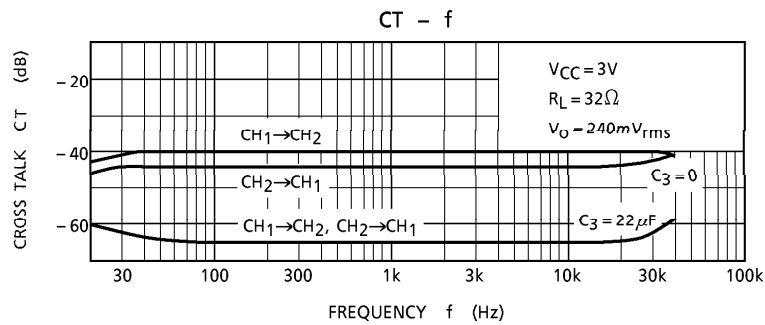
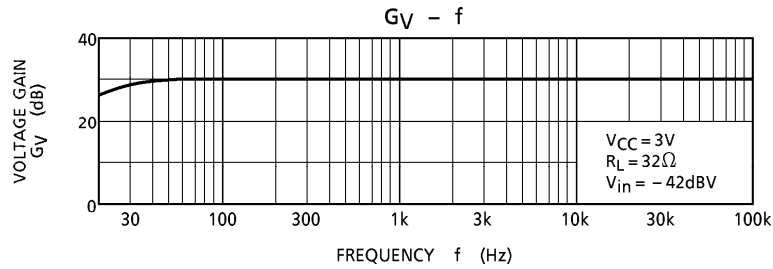
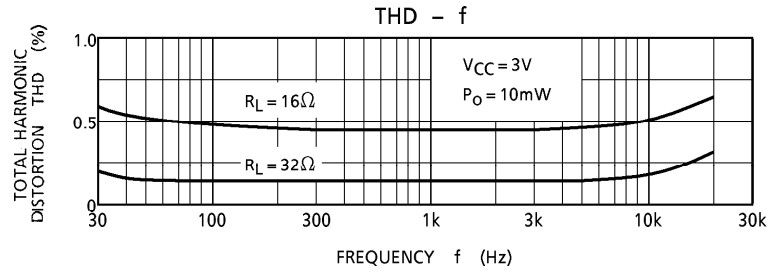
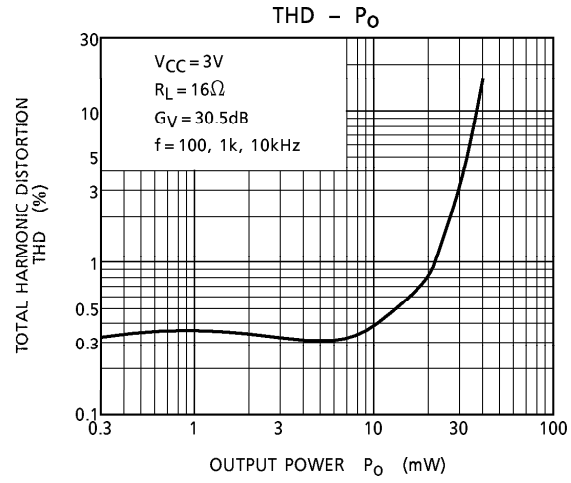
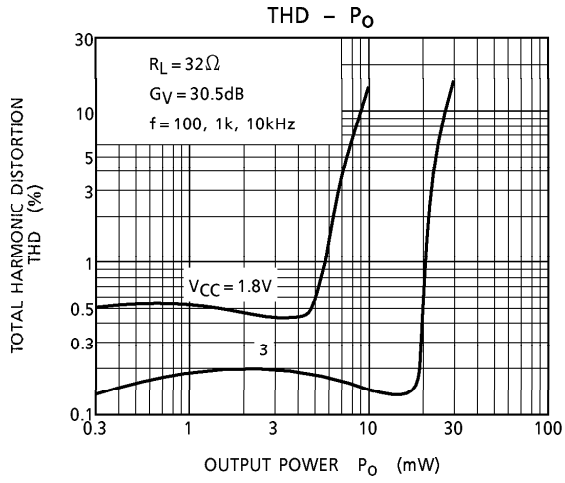

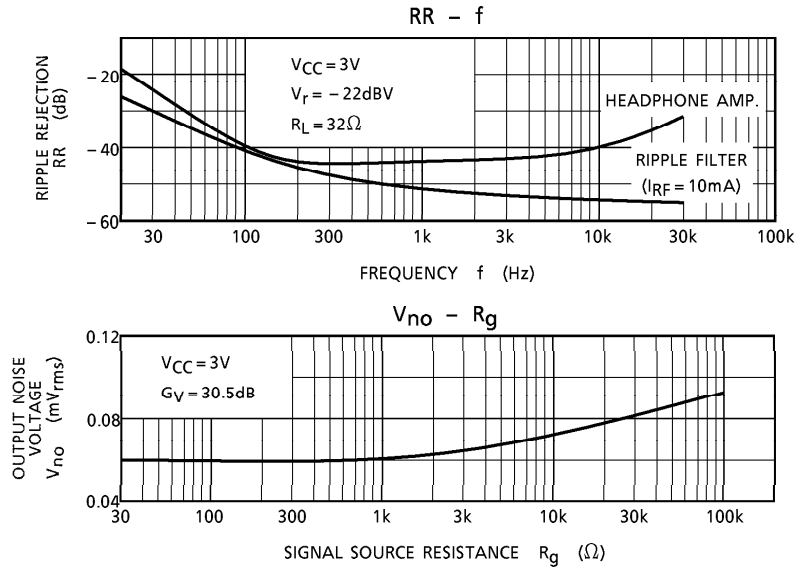

APPLICATION CIRCUIT

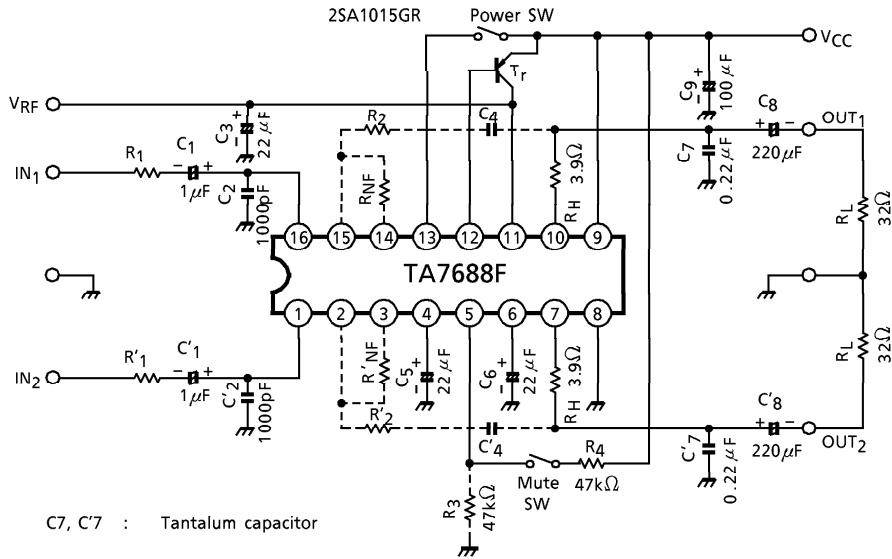

EXTERNAL PARTS TABLE (Mention only CH₁)

PARTS No.	TYPICAL	PURPOSE	INFLUENCE		NOTE
			SMALLER THAN TYP.	GREATER THAN TYP.	
C ₁	1μF	Coupling	Bad low frequency response	"Pop" noise is high.	Input
C ₂	1000pF	LPF	$f_{CH} = \frac{1}{2\pi C_2 (R_1 // Z_{in})}$ - 3dB (30kHz) at R ₁ = 5.6kΩ - 3dB (20kHz) at R ₁ = 12kΩ		Noise receiving protection
R ₁	—				Equivalent signal source impedance
C ₃	22μF	Decoupling for V _{RF}	Stability (OSC) decreases, V _{N0} at V _{RF} increases	(It is better to connect to input side GND)	Use tantalum capacitor
R _{NF}	—	G _V Adjustment	Not available at G _V < 30dB If necessary divide at input level by resistors		—
R ₂	(15kΩ)	f-response control, THD improvement at high freq.	- 3dB point is 20kHz. Check ringing at clip by OSC margine down.		Low OSC margine at G _V < 40dB
C ₄	(180pF)				
C ₅	22μF	Bypass capacitor for bias	THD and V _{N0} Degradation	—	It is better to connect to input side GND.
C ₆	22μF	Bypass capacitor for ripple filter	Ripple rejection ratio degradation	—	It is better to connect to output side GND.
R ₃	47kΩ	Pull down resistor at mute pin	I _{CC} increases at mute ON	Pull down effect down	Additional resistor at long pattern only
R ₄	47kΩ	I _{MUTE} limiter	I _{MUTE} increases (Unnecessary at V _{CC} = 3V)	I _{MUTE} decreases	I _{MUTE} < 150μA
R _H	3.9Ω	Protection resistance. Phase compensation	Rush current increases. Phase compensation is out.	Output decreases. Phase compensation is out.	CR filter with C ₇
C ₇	0.22μF	Phase compensation	Oscillation	THD degradation by load capacitance	Recommended to use tantalum or film capacitor
C ₈	220μF	Coupling	Bad low frequency response	"Pop" noise is high.	Output
C ₉	100μF	V _{CC} decoupling	Oscillation margin decreases	—	Necessary to be near pin 9
T _r	2SA1015GR	Booster for V _{RF}	—	—	To be added at I _{RF} > 10mA

1. f-Resp (Mention Only CH₁)

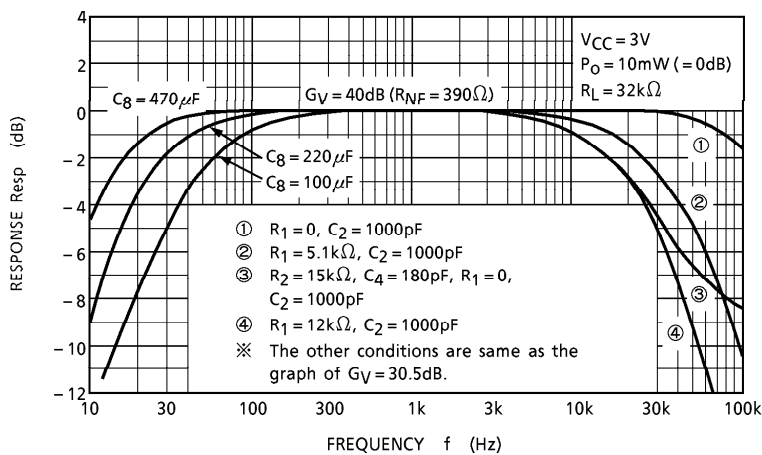
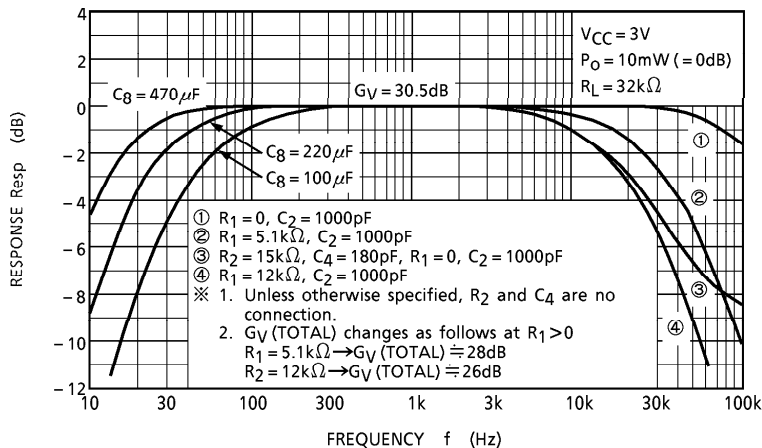

2. P_O -THD (Correspond to 1. f-Resp)

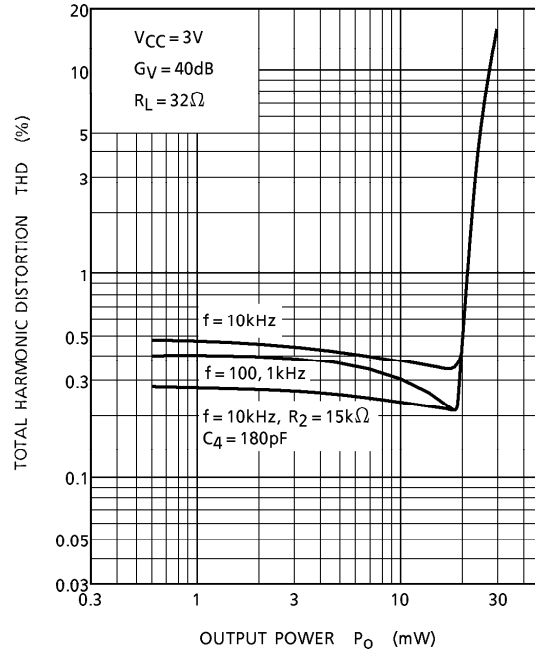
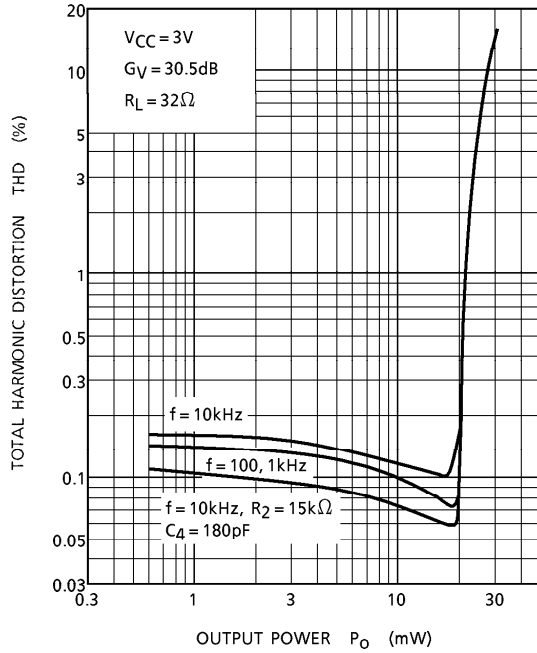

3. I_{RF} - V_{RF}

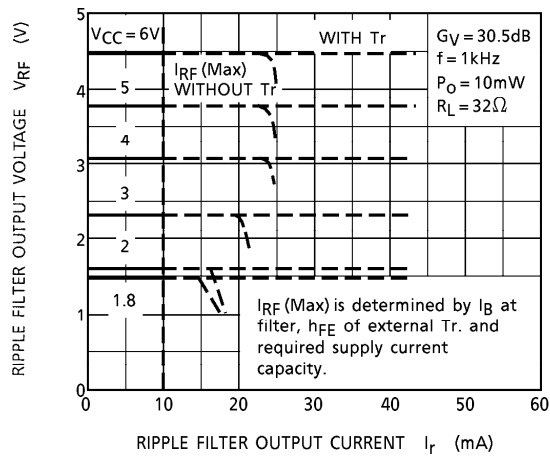

OUTLINE DRAWING
SSOP16-P-225A

Unit : mm

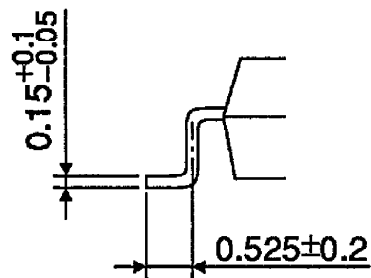
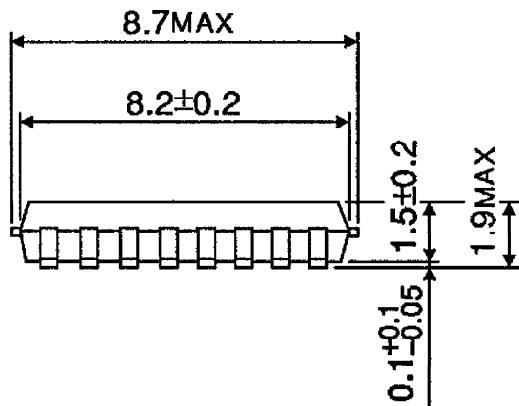
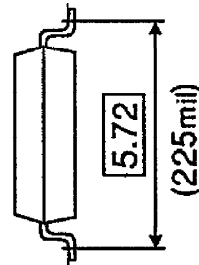
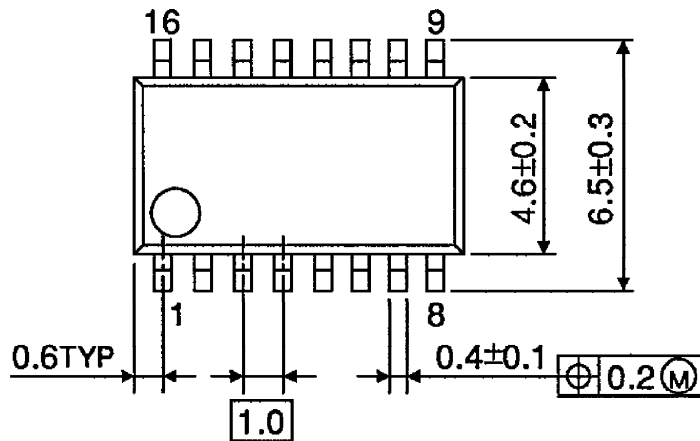

Weight : 0.14g (Typ.)